

# ENGINEERING FIELD MANUAL

## CHAPTER 8. TERRACES

Compiled by: Keith H. Beauchamp, Agricultural Engineer, SCS, Lincoln, Neb.

### Contents

	<u>Page</u>
General . . . . .	8-1
Definition . . . . .	8-1
Introduction . . . . .	8-2
Function of Terraces in the Conservation Program . . . . .	8-2
Applicable State Laws . . . . .	8-3
Planning Techniques . . . . .	8-3
Objectives of a Well-Planned Terrace System . . . . .	8-3
Erosion Control . . . . .	8-4
Farmability . . . . .	8-4
Topography Improvement . . . . .	8-5
Moisture Conservation . . . . .	8-5
Types of Systems . . . . .	8-5
Gradient Terrace System . . . . .	8-7
Gradient Terraces with Waterway Outlets . . . . .	8-7
Gradient Terraces with Underground Outlets . . . . .	8-8
Gradient Terraces with Combination Outlets . . . . .	8-9
Level Terrace System . . . . .	8-10
For Moisture Conservation . . . . .	8-11
Basin Terraces . . . . .	8-12
Soil Considerations . . . . .	8-12
Terrace Outlet . . . . .	8-12
Depth of Cuts . . . . .	8-12
Terrace Cross Section . . . . .	8-13
General . . . . .	8-13
Broad Base Ridge Section . . . . .	8-13
Where Adapted . . . . .	8-13
Advantages . . . . .	8-14
Limitations . . . . .	8-14
Grass Back Slope Ridge Section . . . . .	8-14
Where Adapted . . . . .	8-15
Advantages . . . . .	8-15
Limitations . . . . .	8-15
Borrow . . . . .	8-15
All borrow from upper side . . . . .	8-17
All borrow from lower side . . . . .	8-19

	<u>Page</u>
Channel . . . . .	8-19
Allowance for Freeboard . . . . .	8-20
Terrace Spacing . . . . .	8-20
Terrace Spacing Equation . . . . .	8-21
Universal Soil Loss Equation . . . . .	8-22
Spacing Affected by Cross Section . . . . .	8-23
Spacing Adjusted for Machinery . . . . .	8-24
Alignment . . . . .	8-25
Correction Areas . . . . .	8-25
Point Rows . . . . .	8-26
General Guides for Paralleling . . . . .	8-27
Cut and Fill along the Terrace Line . . . . .	8-27
Varying the Grade Along the Terrace . . . . .	8-28
Divide Terrace into Short Segments . . . . .	8-28
Waterways . . . . .	8-29
Ridges . . . . .	8-29
Layout at Edge of Fields . . . . .	8-31
Gradient Terraces with Waterway Outlets . . . . .	8-31
Gradient Terraces with Underground Outlets . . . . .	8-31
Level Terraces . . . . .	8-32
Layout Geometry . . . . .	8-33
Curves . . . . .	8-33
Parallel Curves . . . . .	8-34
Identical Curves . . . . .	8-34
Reverse Curves . . . . .	8-35
Straight Lines . . . . .	8-37
Curves and Straight Lines . . . . .	8-37
Extension of Parallel Lines . . . . .	8-39
Layout . . . . .	8-41
General . . . . .	8-41
Terraces in Orchards . . . . .	8-41
Farm Roads and Fence Location . . . . .	8-41
Critical Areas . . . . .	8-43
Preliminary Surveys . . . . .	8-43
Topographic Maps . . . . .	8-43
Types of Maps . . . . .	8-44
Planetable or transit . . . . .	8-44
Grid survey . . . . .	8-44
Stereo-photogrammetric plotting . . . . .	8-44
Planning with Map . . . . .	8-44
Field Layout from Map . . . . .	8-45
Layout Staking . . . . .	8-50
The Key Terrace . . . . .	8-51
Analyze the Field . . . . .	8-51
Estimate the Center of the System . . . . .	8-51
Locate the Top of the Hill or Slope . . . . .	8-52

	<u>Page</u>
Determine the Average Land Slope . . . . .	8-52
Determine the Horizontal Interval . . . . .	8-52
Locate Center of Each Terrace Above Key Terrace . . . . .	8-52
Examine the Key and Then Adjust It . . . . .	8-52
Use the Step Offset Method for Staking the Curves . . . . .	8-53
Recheck the Grade . . . . .	8-54
Terraces Parallel to the Key . . . . .	8-54
Design . . . . .	8-55
Terrace Grade . . . . .	8-55
Length of Terrace . . . . .	8-55
Waterway Outlets . . . . .	8-55
Cut-and-Fill Method . . . . .	8-56
Survey the Terrace Line . . . . .	8-56
Analyze the Rod Readings . . . . .	8-56
Determine the Average Rod Reading . . . . .	8-56
Locate the Balance or Midpoint . . . . .	8-56
Determine Grade Rod of the Channel at the Balance Point . . . . .	8-58
Establish the Channel Grade . . . . .	8-58
Determine Cuts and Fills . . . . .	8-58
Graded Terraces Using Underground Outlets . . . . .	8-59
Storage Requirements . . . . .	8-59
Drainage Coefficient . . . . .	8-59
Terrace Storage Capacity . . . . .	8-59
Natural Storage Design Procedure . . . . .	8-60
Excavated Storage Design Procedure . . . . .	8-63
Design of the Outlet Conduit . . . . .	8-67
Intake or Riser . . . . .	8-67
Preventing Pressure Flow in Outlet . . . . .	8-70
Conduit Sizing . . . . .	8-70
Restricting Device in the Intake . . . . .	8-71
Construction . . . . .	8-73
Construction Staking . . . . .	8-73
Balanced Cross-Section Terraces . . . . .	8-73
Cut-and-Fill Terraces . . . . .	8-74
Balanced Section . . . . .	8-74
Excess Borrow Section . . . . .	8-74
Excess Fill Section . . . . .	8-74
Preserving the Survey . . . . .	8-75
Earthmoving . . . . .	8-75
Equipment . . . . .	8-75
Trash and Vegetation . . . . .	8-75
Saving Topsoil . . . . .	8-77
Rough Grading . . . . .	8-77
Balanced Section Terrace . . . . .	8-77
Cut-and-Fill Terrace . . . . .	8-77
Grass Back Slope . . . . .	8-79
Rough Grading Check . . . . .	8-80
Finishing Terrace Cross Section . . . . .	8-80

	<u>Page</u>
Smoothing and Shaping . . . . .	8-80
Installation of Underground Outlet . . . . .	8-82
Farming . . . . .	8-83
Land Preparation . . . . .	8-83
Planting . . . . .	8-84
Maintenance . . . . .	8-87
Broad Base Terrace Systems . . . . .	8-87
Terraces with Grass Back Slopes . . . . .	8-88
Maintenance by Heavy Equipment . . . . .	8-88

### Figures

Figure 8-1	An erosion control terrace planted to row crops . . . . .	8-1
Figure 8-2	Well planned terrace systems . . . . .	8-6
Figure 8-3	Gradient terraces with waterway outlet . . . . .	8-7
Figure 8-4	Gradient terraces with tile outlets . . . . .	8-8
Figure 8-5	Level terraces . . . . .	8-10
Figure 8-6	Cross section of flat channel moisture conservation terraces . . . . .	8-11
Figure 8-7	Terrace cross section showing the three slopes . . . . .	8-13
Figure 8-8	Broad base ridge section . . . . .	8-14
Figure 8-9	Grass back slope ridge section . . . . .	8-15
Figure 8-10	Example of a well maintained grass back slope . . . . .	8-16
Figure 8-11	Comparing uphill and downhill borrow . . . . .	8-16
Figure 8-12	Average slope decreased . . . . .	8-17
Figure 8-13	Terrace cross section on a level area . . . . .	8-17
Figure 8-14	Depth of cut on 4 percent slope . . . . .	8-18
Figure 8-15	Depth of cut on 14 percent slope . . . . .	8-18
Figure 8-16	Slope increased with broad base ridge section . . . . .	8-19
Figure 8-17	No excavation on uphill side . . . . .	8-19
Figure 8-18	Cut measured from 3-foot width on channel and ridge . . . . .	8-20
Figure 8-19	Values of X in Equation VI = XS + Y . . . . .	8-21
Figure 8-20	Spacing affected by cross section . . . . .	8-23
Figure 8-21	Effect of curve between two straight terraces . . . . .	8-26
Figure 8-22	Making terraces parallel by cutting and filling . . . . .	8-27
Figure 8-23	Increasing and decreasing grade by cutting . . . . .	8-28
Figure 8-24	Divide into short segments using all the waterways . . . . .	8-29
Figure 8-25	Right and wrong layout at waterways . . . . .	8-30
Figure 8-26	Layout at ridges and edge of fields . . . . .	8-30
Figure 8-27	Treatment at end of terrace . . . . .	8-32
Figure 8-28	Dividing terrace into various levels . . . . .	8-33
Figure 8-29	Properties of curves . . . . .	8-34
Figure 8-30	Planting on curves . . . . .	8-34
Figure 8-31	Planting toward center of curves . . . . .	8-35
Figure 8-32	Planting away from center of curves . . . . .	8-35
Figure 8-33	Reverse curves . . . . .	8-36
Figure 8-34	Example of reverse parallel curves . . . . .	8-36

Figure 8-35	Reverse curve made gradual . . . . .	8-37
Figure 8-36	Changing staked line to straight line . . . . .	8-37
Figure 8-37	Single curve . . . . .	8-38
Figure 8-38	Parallel lines and curves . . . . .	8-38
Figure 8-39	Layout geometry . . . . .	8-39
Figure 8-40	Extension of parallel lines . . . . .	8-39
Figure 8-41	Stopping parallel lines . . . . .	8-40
Figure 8-42	A gentle curve . . . . .	8-40
Figure 8-43	Illustration of good farm road layout and land use fitted into a terrace system . . . . .	8-42
Figure 8-44	Grid survey map for use in parallel terrace system design and layout . . . . .	8-46
Figure 8-45	Parallel terrace system using tile outlets developed from a topographic map . . . . .	8-48
Figure 8-46	Parallel terrace layout on a topographic map using both tile and waterway outlet . . . . .	8-49
Figure 8-47	Method 1 - Staking . . . . .	8-50
Figure 8-48	Showing first cut . . . . .	8-50
Figure 8-49	Method 2 - Staking . . . . .	8-50
Figure 8-50	Method 3 - Staking . . . . .	8-51
Figure 8-51	Adjustment of line crossing depressions . . . . .	8-52
Figure 8-52	Step offset method for staking a curve . . . . .	8-53
Figure 8-53	Theory of the balance point . . . . .	8-57
Figure 8-54	Graded terrace cut-and-fill notes . . . . .	8-57
Figure 8-55	Storage - Natural and excavated . . . . .	8-60
Figure 8-56	Notes - Graded terrace with underground outlet . . . . .	8-60
Figure 8-57	Profile of terrace . . . . .	8-61
Figure 8-58	Notes - Graded terrace with underground outlet - broad base cross section . . . . .	8-64
Figure 8-59	Profile for terrace design example . . . . .	8-65
Figure 8-60	Examples of "c" and "d" situations for figuring storage . . . . .	8-66
Figure 8-61	Types of opening for intakes of helical corrugated metal pipe . . . . .	8-68
Figure 8-62	Grading around intake . . . . .	8-69
Figure 8-63	Front slope treatment for fills over 3 feet . . . . .	8-69
Figure 8-64	Closeup of intake showing orifice plate location . . . . .	8-70
Figure 8-65	Design head for orifice plate . . . . .	8-71
Figure 8-66	Typical details and placement of intake . . . . .	8-72
Figure 8-67	Staking for balanced sections . . . . .	8-73
Figure 8-68	Marking toe of grass back slope . . . . .	8-73
Figure 8-69	Location of stakes for excess borrow sections . . . . .	8-74
Figure 8-70	Location of stakes for excess fill sections . . . . .	8-74
Figure 8-71	Reference stake . . . . .	8-75
Figure 8-72	Types of earthmoving equipment for terraces . . . . .	8-76
Figure 8-73	Guide for construction . . . . .	8-77
Figure 8-74	Using a dozer to build terraces having cuts and fills . . . . .	8-78
Figure 8-75	Methods of borrow . . . . .	8-79
Figure 8-76	Short rows are created when parallel terraces are not built as staked . . . . .	8-80

	<u>Page</u>
Figure 8-77	Equipment for land smoothing . . . . . 8-81
Figure 8-78	A method of backfilling the underground conduit trench . . . . . 8-83
Figure 8-79	Planting grassed back slope terraces . . . . . 8-85
Figure 8-80	Planting correction areas between broad base terraces . . . . . 8-86
Figure 8-81	A method of intake protection from machinery by maintaining an area of sod around the intake . . . 8-86
Figure 8-82	Results of plowing with a one-way plow . . . . . 8-87
Figure 8-83	Results of plowing with a two-way plow . . . . . 8-87
Figure 8-84	The three land method of plowing terraces . . . . . 8-89
Figure 8-85	A method of plowing grass back slope terraces . . . 8-90

### Tables

Table 8-1	Terrace spacing for 30- and 40-inch equipment . . . 8-24
-----------	--

### Exhibits

Exhibit 8-1	Cut in channel in feet for broad base terraces . . . 8-91
Exhibit 8-2	Natural storage above terrace (cu.ft./lin.ft.) . . . 8-92
Exhibit 8-3	Terrace storage table . . . . . 8-93
Exhibit 8-4	Tile design chart for underground outlets . . . . . 8-101
Exhibit 8-5	Discharge rates of circular orifice in c.f.s. . . . . 8-102
Exhibit 8-6	Drain chart - corrugated plastic drain tubing . . . . 8-103

# ENGINEERING FIELD MANUAL

## CHAPTER 8. TERRACES

### 1. GENERAL

#### DEFINITION

A terrace is an earth embankment, or a ridge and channel, constructed across the slope at a suitable location to intercept surface runoff water. It may be constructed with an acceptable grade to an outlet or with a level channel and ridge.



Figure 8-1 An erosion control terrace planted to row crops

## INTRODUCTION

Terraces are constructed to reduce erosion by shortening the length of slope and conducting the runoff water on a nonerosive grade to a stable outlet. They are used also to conserve moisture; reduce floods by means of level closed terraces, or by increasing the time of concentration with graded terraces; and to control gully heads downstream.

Terracing is one of the best mechanical erosion control practices. To be accepted by farmers, terraces must have desirable shape and alignment and be farmable with modern equipment.

## FUNCTION OF TERRACES IN THE CONSERVATION PROGRAM

Terraces that are properly located, constructed and maintained reduce runoff and soil losses and prevent the forming of rills and gullies. They assist in reclaiming badly gullied fields by intercepting the runoff before it becomes concentrated and attains an eroding velocity. Terraces prevent the loss of costly seed and plant foods. To be effective, they must be used in combination with other practices, such as stubble mulching, contouring, and stripcropping. Over a period of years, better crops may be expected on terraced land because of the soil and moisture they save.

Terraces are of value on practically all soils except those that are too stony, sandy, or shallow to permit practical and economical construction and maintenance. They are normally used only on cultivated lands. However, some badly eroded lands may be so severely gullied that it would be difficult to establish grass. In such instances, terraces are necessary on grassland.

Frequently, the less productive soils are not terraced until the soil has become so badly eroded that construction is costly, maintenance is excessive, and farming operations are difficult. Terraces pay the smallest returns when used to reclaim fields that are already badly eroded and gullied.

It is not advisable to terrace some lands where the slope of the land is either too slight or excessive, or the topography is extremely irregular.

The steepness of the land is one of the factors that determines the practicability of terraces. As the land slope increases, soil loss from erosion increases. However, the cost of construction and maintenance of terraces and the difficulty of farming them increase with the degree of slope to the point that these factors may eventually outweigh the benefits derived. When this point is reached, terracing is not advisable. On the other hand, terraces may be needed on long slopes as gentle as one-half foot per 100 feet to reduce erosion caused by concentrations of water.

The steepest slope on which terracing is practical is not determined by formula but by the economics, industry of the operator, and the accompanying conservation practices applied. Terraces are being employed successfully on slopes as steep as 12 percent on residual and glacial

soils and on slopes up to 20 percent on loess soils, when proper land use is practiced.

It is difficult to lay out a farmable terrace system on very irregular slopes. Curves that are too sharp for modern farm machinery cannot be avoided, except by excessive cuts and fills. Most soils in this type of topography are too shallow to permit deep cuts. Hence, spacing between terraces will vary and cause many point rows.

### APPLICABLE STATE LAWS

Applicable state laws governing the diversion of water must be followed in planning and installing terrace systems. Generally, state laws require that water must not be diverted so that it leaves a farm at a point other than the natural watercourse.

### PLANNING TECHNIQUES

A major requirement of a good terrace system for row crops is that the terraces must have the best possible alignment and be parallel wherever possible. With parallel terraces, each terrace is planned as part of a total system. A parallel terrace system can have correction areas provided they occur between sets of parallel terraces. However, the correction areas should be located carefully.

A number of techniques can be used to improve the farmability and to assist in making terraces parallel. Some are:

1. Choice of outlets. On some fields, grass waterways may be best for outlets. Some jobs may require an underground outlet, commonly known as the tile outlet. On others, the terraces may be built level with closed ends so that the outlet is the soil itself.
2. Choice of terrace cross section. The cross section may be either broad based or have a steep grass backslope. This will depend upon the soil, the slope of the field, and the wishes of the farmer. The terrace channel may be either flat or V-shaped.
3. Making terraces parallel. The cut-and-fill method may be used on some fields. On others, parallel layouts may be made by varying the grade, using grass turn strips, and other techniques.

All of these techniques should be considered in the layout of any terrace system. A well-planned system requires thoughtful, detailed planning which will result in a system that is easy to farm and maintain.

## 2. OBJECTIVES OF A WELL-PLANNED TERRACE SYSTEM

There are several general objectives to be kept in mind in terrace planning. These are erosion control, farmability, topography improvement, and moisture conservation where level terraces are used.

## EROSION CONTROL

Erosion control is the prime objective in terracing. The technician should consider the allowable soil loss, the most intensive use expected for the land, and the expected level of management in planning terraces for erosion control. This means that terraces must generally fit the contour of the land. Deviations from the selected grade must be limited, and allowed only when necessary to obtain good alignment.

## FARMABILITY

Farmability is a second important objective. Terraces must be as farmable as possible in order to have them accepted and maintained. A terrace system with good farmability will:

1. Have the best possible alignment and be parallel wherever possible for row crops. This will reduce point rows, save time in plowing, planting and harvesting, and reduce crop damage caused by turning between terraces. When only grain or hay crops are grown, parallel terraces are not so important provided the terrace cross section is flat enough to permit easy crossing with farm machinery.
2. Be spaced to fit the equipment used in the area. If farmers are using 4-row equipment, terracing spacing should be adapted to multiples of four rows. If the trend is 6- and 8-row equipment (or other special types) terrace spacing should be planned, if possible, to fit present and future equipment.
3. Be spaced as wide as possible without exceeding the allowable soil loss.
4. Be planned and constructed with a workable cross section. The cross section should not increase the slope of the land to the point where it is difficult to farm. Some terracing increases the slope of the land between the terraces because earth is taken from the channel and placed in the ridge. An increase in slope can be tolerated on the flatter land but any increase in slope on steep land tends to make farming operations slower, decrease stands, and reduce efficiency. One solution on the steep land is to develop a steep terrace back slope and seed it to permanent vegetation. Another is to borrow fill material below the terrace to make the ridge, and seed the steep back slope. These methods will flatten the land between terraces and should be used where applicable.
5. Provide good access roads to all parts of the terraced field. This is very important for erosion control. Roads can be provided on field ridges, along the side of grass waterways, and along field boundaries. Waterways should never be used for roads.

## TOPOGRAPHY IMPROVEMENT

In planning a terrace system to improve the topography of a field, the terraces are laid out fairly straight and smooth, taking them directly across minor draws and gullies. After the terraces are built there will be some soil movement in the terrace interval, caused both by equipment and by water. However, any soil that moves will be deposited in low areas, thus smoothing the field and making it more farmable.

Another method of improving the topography of a field is to do some benching or promote benching between terraces. Benching between terraces will occur to some extent on steep slopes with wide spacing, intensive cropping and improper plowing. On deep soils of fairly uniform texture, such as the deep loess soils, benching between parallel terraces will provide a flatter slope to farm, better moisture distribution over the benched area, and reduce downhill sliding of equipment. By constructing terraces mainly from the downhill side the slope between terraces will be reduced. Then there are two ways to speed up the benching process:

1. Use earthmoving equipment to construct the bench at the time the terraces are installed. On steep slopes this is very costly.
2. Speed up the natural process by plowing to move the soil downhill. The spacing must be set so that the terrace ridge can be raised as needed.

Often, it is desirable to do some land grading of the entire field, or between terraces after they have been built. This is necessary if old conventional terraces still remain in the field. Also, there may be depressed areas that will continue to slow the movement of water into terrace channels unless graded out. Land grading should be considered as one means of topography improvement.

## MOISTURE CONSERVATION

In areas of low rainfall, and particularly in the semiarid regions where the soil is highly permeable, level terraces with closed ends are used for moisture conservation as well as erosion control. Surface runoff is stored back of the terrace ridge and is slowly absorbed by the soil.

### 3. TYPES OF SYSTEMS

There are two major types of terrace systems based on the disposal of runoff. One is the gradient terrace system and the other the level terrace system. The system to be used will be determined by the characteristics of the soil to be terraced and the rainfall.

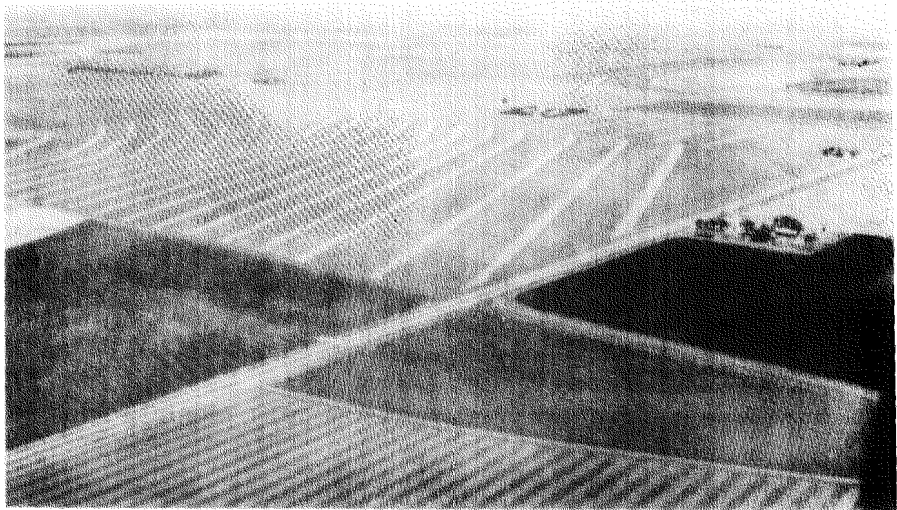

Figure 8-2 Well planned terrace systems

## GRADIENT TERRACE SYSTEM

Gradient terraces carry the collected runoff in a graded channel to an outlet. Outlets are of two types, surface or subsurface. Surface outlets are waterways either natural or constructed. Subsurface outlets are underground conduits, such as tile or pipe.

### Gradient Terraces With Waterway Outlets

The gradient terrace which uses a grass waterway for an outlet is the most common type. Erosion is controlled because the slope length of the field is reduced to that of the terrace spacing. When runoff occurs, the flow travels overland to the terrace and thence along the terrace at a safe velocity to the waterway outlet. See Figure 8-3.



Figure 8-3 Gradient terraces with waterway outlet

Channel grades may be either uniform or variable. Grades should be sufficient to provide good drainage and develop adequate flow without scouring the channel and washing out crops.

This type of terrace system requires an outlet of suitable capacity that can be maintained in good vegetative cover. Gullies developing in an outlet could extend up the terrace channels, causing failure of the entire system. The location of the outlet will depend primarily upon topographical features, types of outlets to be used, and the effect of the location

on the convenience of carrying out farming operations. Refer to Chapter 7 for additional information and design criteria for vegetated outlets.

Grade control structures in vegetative outlets will be needed where flow velocities are greater than the sod can handle; at gully heads that are impractical to blade out; and at junctions with another outlet where it is necessary to raise the end of the waterway above unfavorable conditions for sod growth because of poor soil, rocky, or wet conditions. See Chapter 6 for information on structure selection.

### Gradient Terraces With Underground Outlets

With this type of terrace system the outlet is a conduit made of tile, pipe or other suitable material. The terrace channel is graded to the outlet as with all gradient terraces. However, the terrace ridgetop usually is built level to provide capacity to store the design storm runoff.

Water enters the conduit through an intake placed in the terrace channel. The outlet conduit is designed to remove the runoff gradually but soon enough so that crop damage will not occur. This design allows for a more reasonable size of conduit than would be possible if it had to handle peak flows. Since tile drainage is oftentimes needed in the low areas to collect and remove seepage, this type of outlet provides for double usage of the tile line. See Figure 8-4.

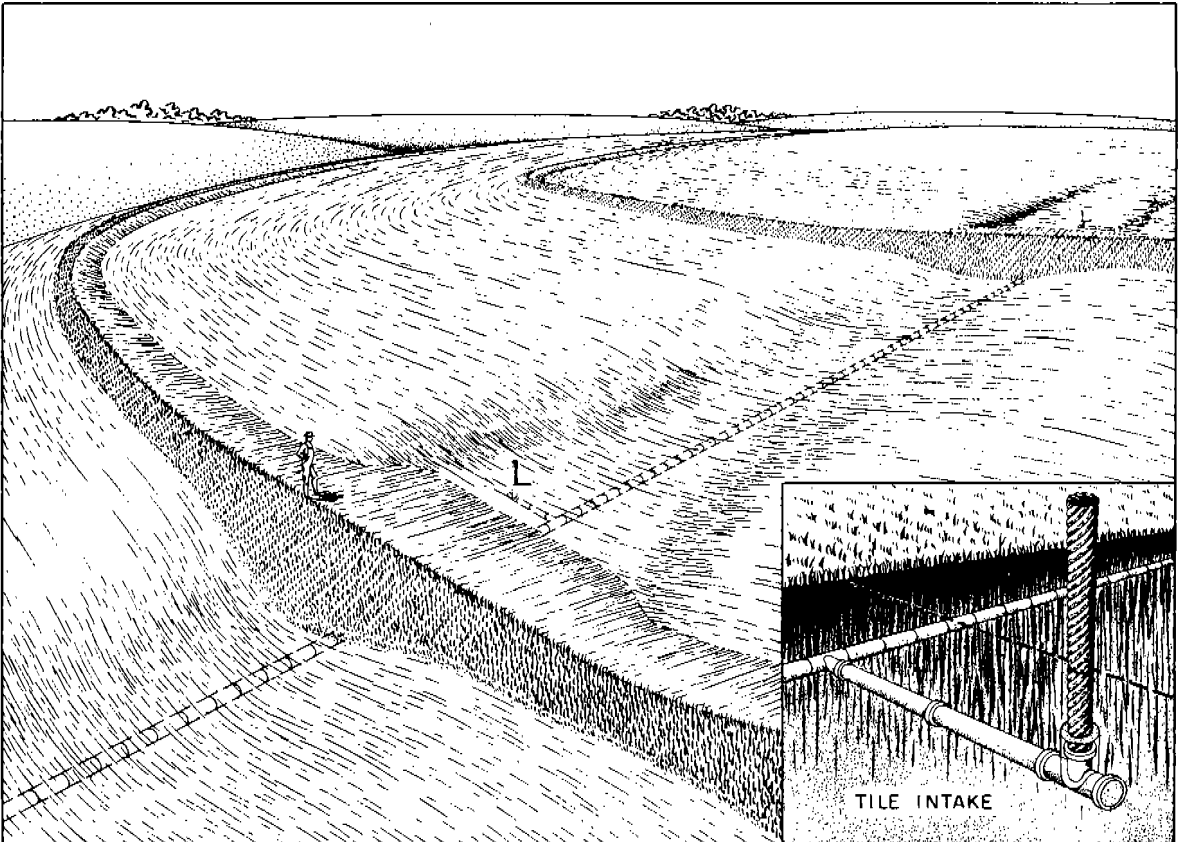

Figure 8-4 Gradient terraces with tile outlets

The two main advantages of the underground outlet are that it promotes parallel alignment and eliminates the need for grass waterways. The use of this type of outlet requires the terraces to be built across the depressions and waterways with the intake being placed at the low point on the terrace profile. With shallow depressions the terrace can be built straight across, thus giving a straighter line than if a surface outlet were used. Straighter lines are easier to parallel.

With the underground outlet, steeper grades can be permitted in the terrace channel near the outlet. This is because the larger rains will cause water to be stored at the outlet, which will reduce the grade of the water surface and thereby reduce the velocity. The velocity of flow from small rains will not be a problem. By being able to steepen grades at the larger depressions or waterways where outlets will be established, straighter alignment is possible.

The elimination of surface outlets means more land in crops in a terraced field. In locations where there are no tile lines in the waterways the installation cost of tile outlets will generally be higher than surface outlets in natural waterways. Where tile lines are available, inlet costs may not exceed the cost of shaping, fertilizing and seeding natural waterways. Maintenance time and costs should be less for the conduit type outlet.

Another advantage of the underground outlet is that it provides a certain amount of land restoration or topography improvement. If natural waterways are rather deep, the placing of an intake at these low points with a fill straight across the waterway will trap any sediment that moves. This will eventually level out the area and provide a more farmable land surface.

The underground outlet is adapted to soils of low to moderate permeability in all rainfall areas. It is particularly adapted to topography where waterways are shallow and numerous. It is especially valuable where waterways are difficult to maintain. Terraces are easier to parallel on rough topography and the alignment can be greatly improved in terrace systems not planned to be parallel.

#### Gradient Terraces With Combination Outlets

There are locations where both surface and underground outlets should be used to provide the best terrace system. Where straightening the alignment and developing a good sod are not a problem, the vegetative outlet might work better for a part of the system. In another part of the same system, with rougher topography and deeper draws, the tile outlet might be more suitable.

Where there is a good vegetated waterway that does not require tile it should be used to serve as much as possible of the system. Where only a portion, or one end, of a terrace requires an outlet, the possibility of a surface outlet should be explored. Another portion of the field might have numerous waterways or draws that could be eliminated with underground outlets.

Where good vegetation is difficult to establish or maintain and sufficient storage for an underground outlet is impractical to construct, a standard broad base terrace can be constructed across the waterway at either the first or second terrace from the top. The terrace slopes should be seeded to permanent vegetation and an underground outlet provided for low flows and snowmelt that cause undue erosion in a vegetated waterway.

The technician should carefully study the topography of the field and the location of required outlets and use the type of outlet best adapted for each location.

### LEVEL TERRACE SYSTEM

A level terrace is constructed with no channel grade. The channel and ridgetop are built level so that runoff is stored along the terrace. The ends of the terrace usually are closed; therefore, the soil absorbs the water and serves as the terrace outlet. See Figure 8-5. Sometimes the ends of the terrace are left open or partially open. In these cases adequate outlets must be available. The outlet may be a grass waterway, vegetated area, or tile outlet.

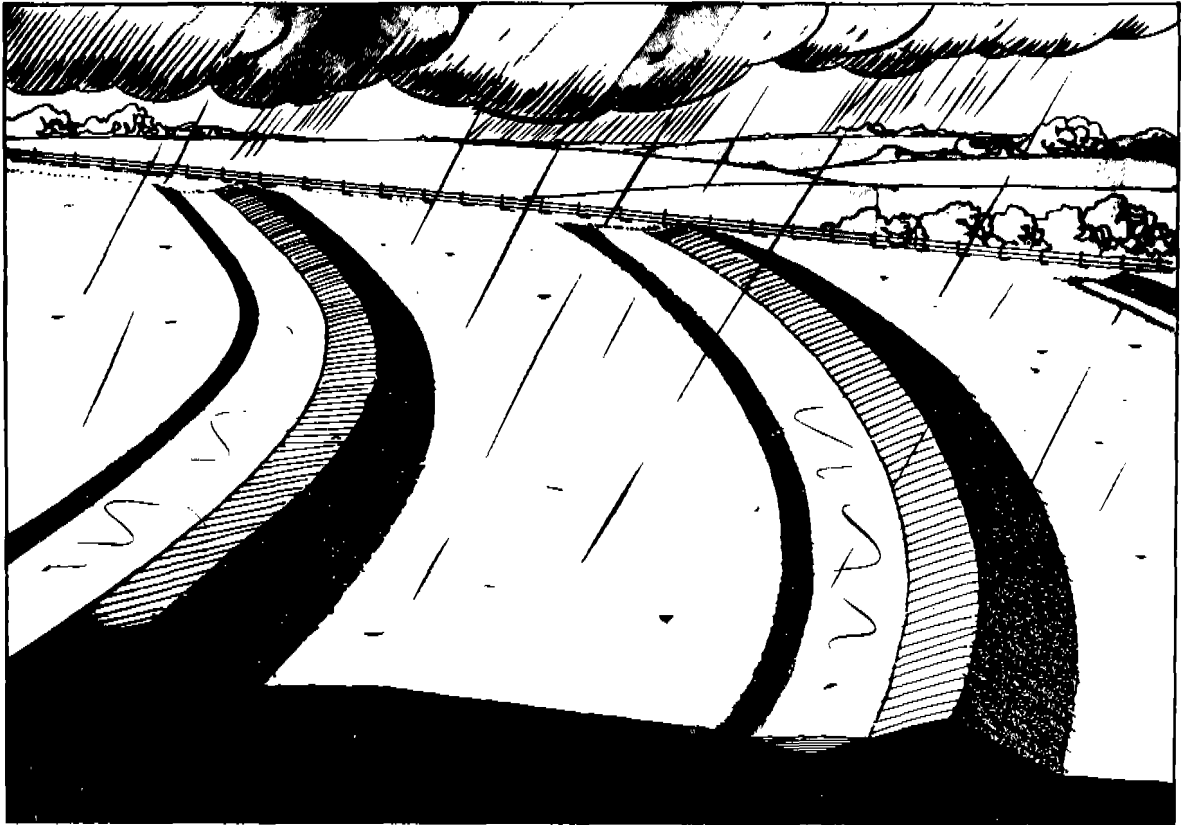

Figure 8-5 Level terraces

The level terrace with complete or partial end closures can be used only on highly permeable soils capable of absorbing the runoff rapidly enough to prevent damage to terraces and crops. On less permeable soils no end closures are used. This type of terrace is adapted to areas of low to moderate rainfall, generally not to exceed a 25- to 30-inch annual rainfall depending upon soil depth and texture.

The level terrace is used both for erosion control and water conservation. It is generally used in areas of suitable soils where outlets are a problem and runoff from the area must be kept to a minimum or entirely eliminated. It is particularly adapted to areas of low rainfall for conserving moisture.

The soils on which level terraces are needed for erosion control usually are highly productive but quite erodible. The land is often carved with shallow gullies. Level terracing will control and smooth out the land in these situations, in addition to conserving moisture.

Storage requirements of level terraces necessitate a fairly large cross section. The terraces must be large enough to contain the design storm runoff without overtopping the terrace ridge. Overtopping may start a chain reaction from terrace to terrace with increasing damage. The runoff volume of a 10-year frequency storm is used to determine the required storage capacity for closed level terraces.

#### For Moisture Conservation

Level terraces are used for moisture conservation and erosion control in areas of low rainfall. The terraces collect and store surface runoff so that it can be absorbed into the soil. All surface runoff is thereby converted to soil moisture.

In some areas a special type of level terrace called flat-channel terrace or conservation bench is used for moisture control. This terrace is constructed with a ridge and a wide, flat channel as shown in Figure 8-6. The terrace ridge controls the impounding and spreading of runoff water. The level bench or channel serves as a catchment area for surface runoff from the terrace interval.

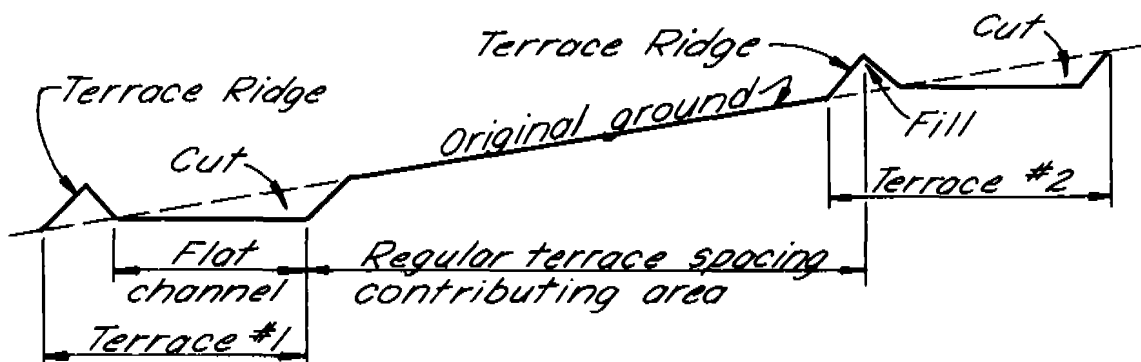

Figure 8-6 Cross section of flat channel moisture conservation terraces

The terrace ends are closed or partially closed to retain the water on the flat channel. The flat channel section is designed to fit the equipment used. The channel width depends also on the slope of the land and should be designed so that channel cut will balance with ridge fill. Width also depends upon land use and anticipated runoff. Usually this type of terrace is adapted to slopes up to 4 percent with channel widths varying from 30 to 70 feet. Terrace spacing may be the same as for regular terraces plus the width of the flat channel section. The channel provides an area of uniform width and level land for farming row crops. The contributing area is generally used for small grain.

### Basin Terraces

The basin terrace is a form of level terrace with closed ends constructed on noncropped deep permeable soils and designed to impound a given amount of runoff from its drainage area above. Usually it is constructed at the base of steep noncultivated land that is not terraceable. The terrace will retain the runoff from the noncropland area, thereby checking erosion on the lower slopes, preventing gully development, reducing flooding and increasing infiltration opportunity.

The basin terrace should have a storage capacity, without overtopping, adequate to handle the expected runoff volume of a 10-year frequency storm. A nonfarmable cross section is generally used with terrace side slopes steeper and narrower than cropland terraces. The channel can be parabolic, V-shaped or trapezoidal.

## 4. SOIL CONSIDERATIONS

In planning any system the soil is the first consideration. The soil characteristics will generally determine the type of terrace and outlet that can be used, the amount of cutting that can be tolerated, and the spacing.

### TERRACE OUTLET

Where the soil is deep and highly permeable (like deep loess) level terraces can be built. In such cases, the soil along the terrace channel will absorb the impounded runoff and serve as the terrace outlet.

If the soil is not deep and permeable, the terrace should be graded to an outlet. Therefore, the soil dictates the type of outlet required and hence the type of terrace system.

### DEPTH OF CUTS

Adequate investigation should be made to determine the depth of topsoil. Larger cuts can be made on deep soils to improve alignment without exposing unfavorable subsoil. Economics may be the determining factor, however, cuts must be kept to a minimum, which limits the flexibility of the layout.

The exposing of small amounts of unfavorable subsoil is permissible in order to obtain satisfactory alignment of a parallel terrace system. When evaluating the soils, the improvement of the entire field should be weighed against exposing small infertile areas.

Consideration should be given to the time and cost of restoring exposed subsoil to good productivity. Some subsoils respond more quickly to treatment than others. One other approach on shallow soils is to stockpile topsoil before construction, remove the borrow, and replace the topsoil. This is a more costly method but it permits better alignment without seriously depressing yields.

## 5. TERRACE CROSS SECTION

### GENERAL

The terrace cross section, consisting of channel and ridge must be proportioned to fit the land slope, the crops grown and farm machinery used. It is made up of three side slopes known as the cut slope, front slope and back slope as shown in Figure 8-7. The steeper limits for side slopes are generally accepted as 5:1 for row crops and 4:1 for drill crops.



*Terrace Cross Section Showing the Three Slopes*

Figure 8-7 Terrace cross section showing the three slopes

The terrace channel may be either trapezoidal or V-shaped. There are two basic ridge sections for terraces, based on whether or not the entire section is farmed. It is necessary to select the type of cross section before any layout can be made as the cross section affects terrace spacing. See section on terrace spacing.

### BROAD BASE RIDGE SECTION

The broad base terrace is constructed so that modern farm machinery can operate over the cut slope, front slope, and back slope without difficulty. The front slope is made a width which fits the common machinery in the area. The cut slope and the back slope are made at least as wide as the front slope. Borrow is usually taken from the uphill side. (See Figure 8-8.)

### Where Adapted

The broad base ridge section is generally adapted to the land slopes less than 8 percent. On steeper slopes it will be difficult to make the back slope farmable. It is better adapted to smooth topography rather than rough.



Figure 8-8 Broad base ridge section

#### Advantages

The entire terrace can be farmed with no land lost to crops. There is no problem of weeds, trees, and burrowing animals.

#### Limitations

This ridge section requires a large amount of earthfill because all back slopes are relatively long. This is especially true where large fills are necessary. On steep land it is difficult to keep the back slope from getting too steep, thereby presenting a safety hazard. It should not be used on land with slopes over 10 percent. This type of section tends to increase the land slope appreciably between terraces on the steeper land.

#### GRASS BACK SLOPE RIDGE SECTION

The grass back slope ridge section is constructed with a steep back slope, generally 2:1. Since the back slope is too steep for row crops, it must be maintained in sod. The front slope is made to fit the farm equipment. The cut slope, where borrow is taken on the uphill side, generally is made at least as wide as the front slope so that it, too, is farmable. See Figure 8-9.

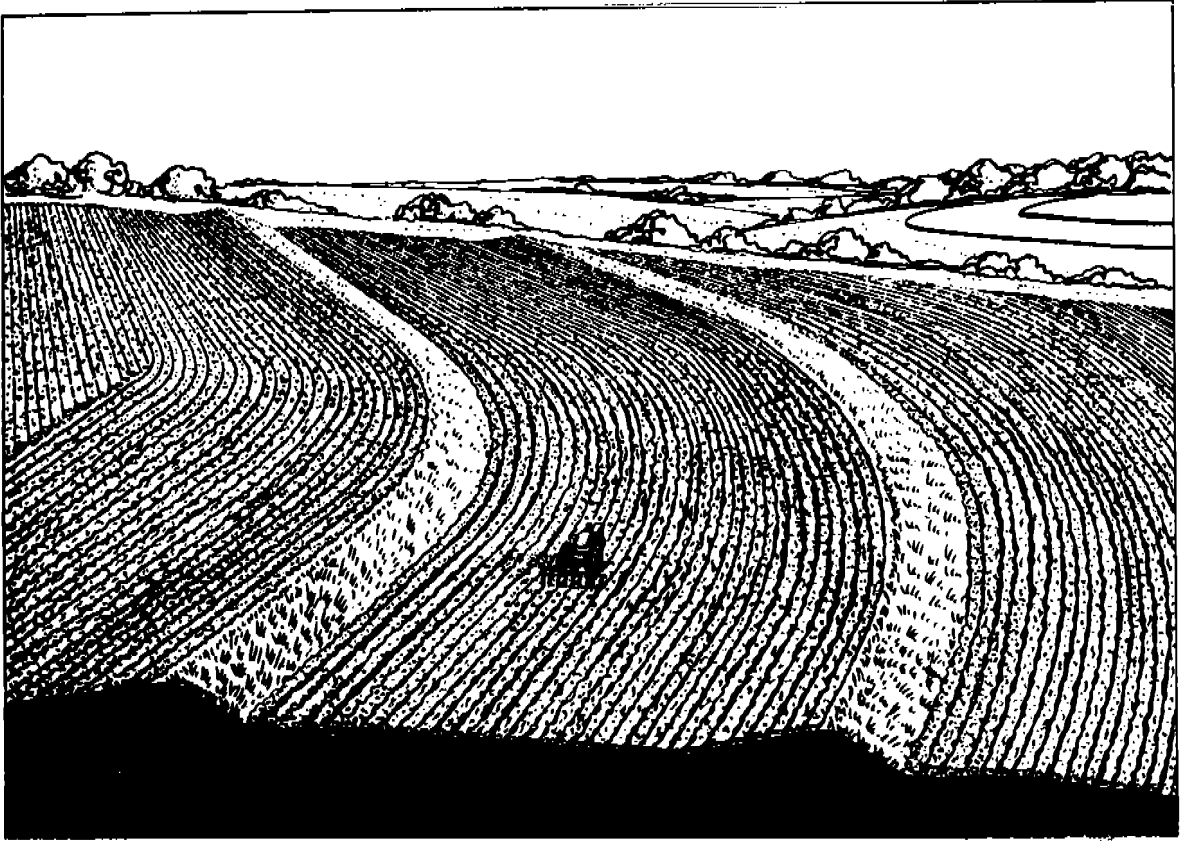

Figure 8-9 Grass back slope ridge section

#### Where Adapted

The grass back slope ridge section is better adapted to slopes of 6 per cent or greater.

#### Advantages

The grass back slope ridge section, particularly when borrow is taken from the downhill side, makes the land more farmable. Also, the slope of the land between terraces is reduced. Less earth is required in the heavier fills. The safety hazard associated with farming steep back slopes is removed. Note good grass back slope in Figure 8-10.

#### Limitations

The back slope must be maintained in sod. Trees, weeds, and burrowing animals must be controlled. A small portion of the land is removed from cropland and each terrace interval is a separate field.

#### Borrow

Borrow can be taken all from the uphill side, all from the downhill side, or from both sides. When borrow is taken only from the upper side, less earthfill is required in the terrace ridge because part of the

capacity of the terrace is in the excavation. However, borrow all taken from the upper side on the steeper land will cause a steep cut slope.



Figure 8-10 Example of a well maintained grass back slope

Where borrow is taken only from the downhill side, the depth of earth-fill placed in the terrace ridge must be greater because capacity occurs only above the natural ground, with no excavated capacity. (Figure 8-11)

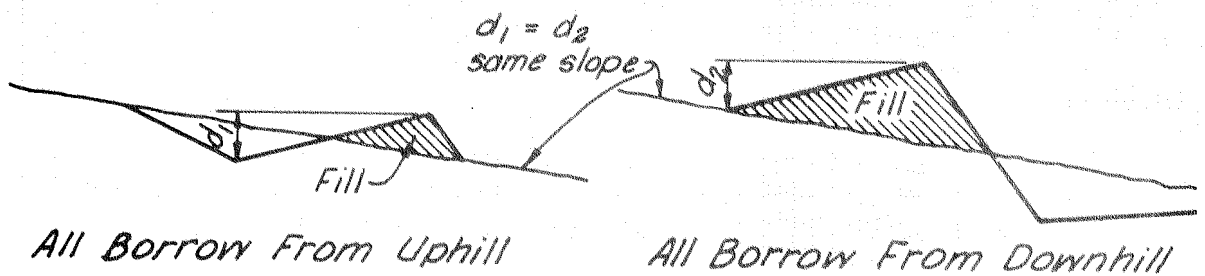

Figure 8-11 Comparing uphill and downhill borrow

However, terraces built with downhill borrow alone will decrease the average slope of the farmed area between terraces about 2 to 4 percent on the steeper land. This makes the land more farmable. See Figure 8-12.

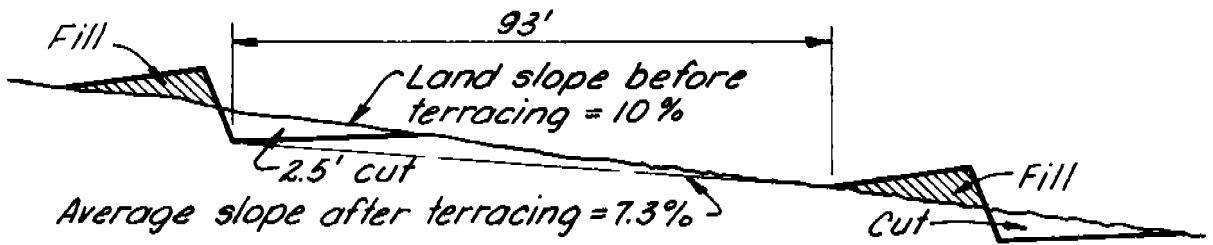

Figure 8-12 Average slope decreased

Borrow can be made from both sides, particularly on slopes steeper than 12 percent. This reduces terrace height and yardage as compared to terraces built entirely from the lower side. The back slope is still left steep and is seeded.

When cuts and fills are made along the terrace line, borrow should be taken from the ridges and moved to the depressions. This will reduce the slope in the channel and the slope of those rows close to the terrace. It also tends to level out the land and make the width of the back slope more uniform which makes the system more farmable.

#### All Borrow from Upper Side

The effect of borrow from the upper side, and the effect of land slope on the cross section of the terrace should be considered. In the usual case, the cut slope and back slope are made equal in length and excavation approximately equals the earthfill. This assumes no shrink or swell of the borrow, which is generally true. The result is two triangles, with the area of the borrow triangle equal to the area of the earthfill triangle. Therefore, the depth of cut equals the depth of fill.

Figure 8-13 shows an assumed case of a terrace built on a level area. If the terrace is to be 1.0 foot in total height, it will be necessary to excavate 0.5 foot, fill a like amount, and the resulting height (from bottom of excavation to top of fill) will be 1.0 foot.

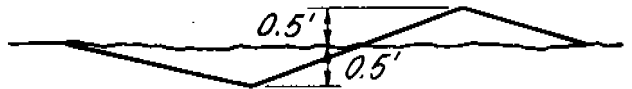

*Terrace Cross Section  
on a Level Area*

Figure 8-13 Terrace cross section on a level area

A more realistic case is a terrace on a 4 percent slope. Again determine the depth of cut necessary for the 1.0-foot terrace. First determine the depth necessary to level the land. If the terrace front slope is 15 feet in length the land slopes  $15 (.04) = 0.6$  foot in this length. Thus, it will be necessary to cut 0.3 foot and fill 0.3 foot to level the area. Now to make the terrace one foot high, it will be necessary to cut an additional 0.5 foot. Thus, the total cut will be 0.3 foot plus 0.5 foot or 0.8 foot. (Figure 8-14)

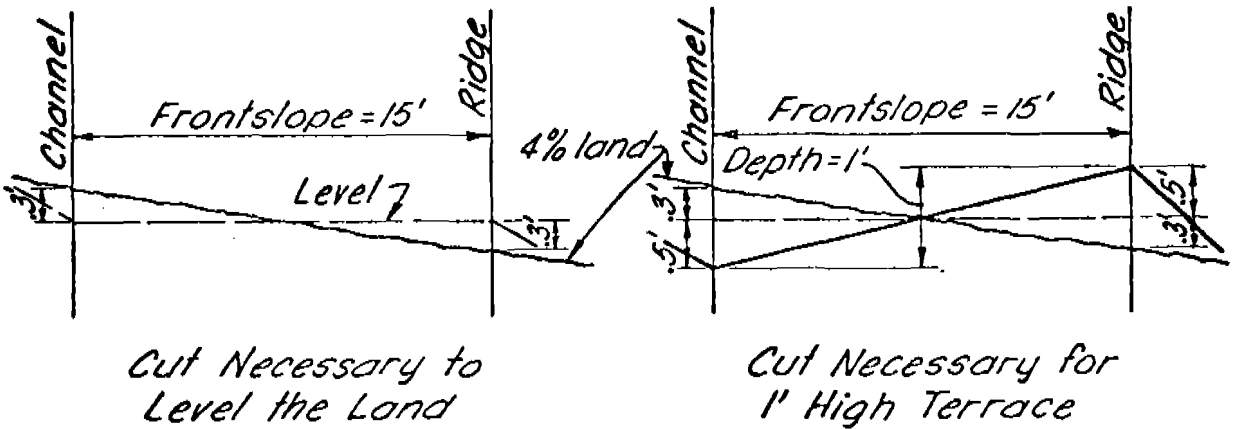

Figure 8-14 Depth of cut on 4 percent slope

Now consider a similar terrace on a 14 percent slope. The land slopes 2.1 feet in the 15 feet from the channel to the ridge. A cut of 1.05 feet will be necessary to first level the area. Add to this an additional 0.5 foot as before, and it is found that a total cut of 1.55 feet is necessary for the same 1.0-foot high terrace. (Figure 8-15)

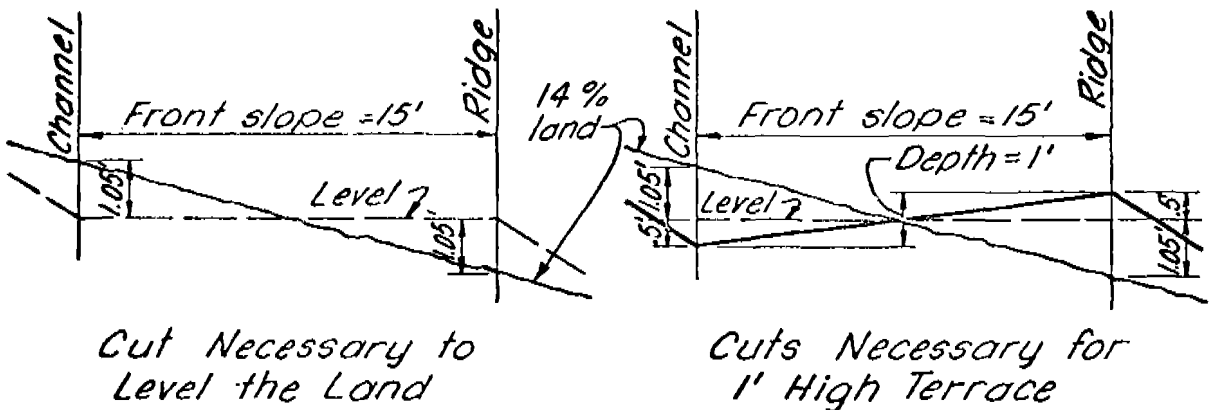

Figure 8-15 Depth of cut on 14 percent slope

The above illustrations show that with the broad base cross section cuts become deeper as the land slope becomes steeper.

Consideration also should be given to the effect on land slope when terraces are built with borrow from the upper side. Take as an example a 14 percent slope. As was shown above, a cut of 1.55 feet and a fill of 1.55 feet were necessary for a 1.0-foot terrace. If the terraces are 80 feet apart, the new average slope will be increased by 4.8 percent to 18.8 percent.

$$\frac{(65)(.14) + 1.55 + 1.55}{65} = 0.188 \text{ or } 18.8 \text{ percent}$$

This is based on measuring the new slope from the top of the terrace ridge to the bottom of the channel of the next lower terrace, a distance of 65 feet. Thus, it can be seen that broad base terraces increase the slope considerably on the steeper land. (Figure 8-16)

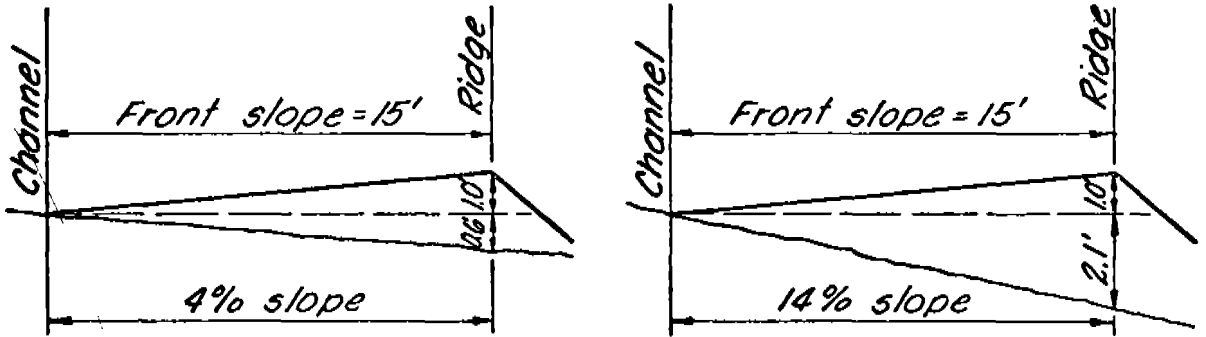

Figure 8-16 Slope increased with broad base ridge section

#### All Borrow from Lower Side

Consider the fill height at the terrace if there is no excavation on the uphill side. For the 4 percent slope, the fill height needed to level the base is 0.6 foot. An additional 1.0 foot is necessary to give the one foot fill height, making 1.6 feet total fill. This is twice as high a fill as when borrow was made on the uphill side. This same relationship is true for all slopes. (Figure 8-17)

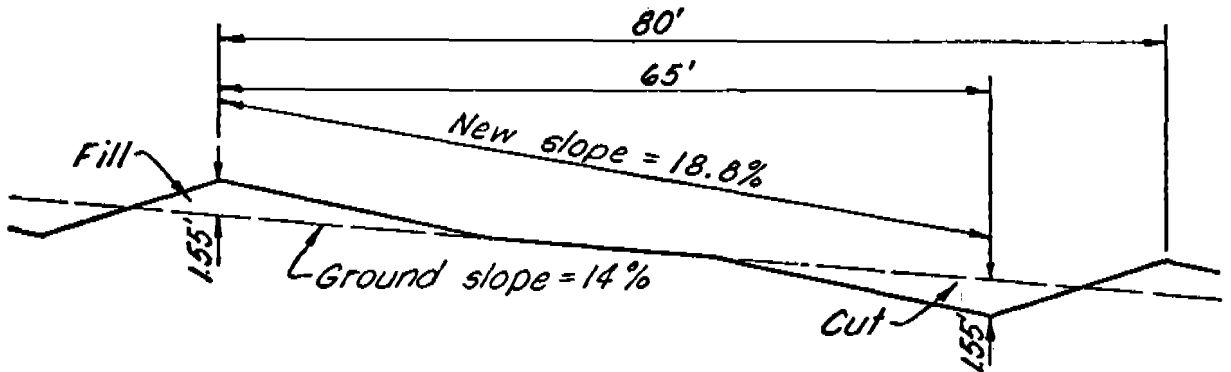

Figure 8-17 No excavation on uphill side

#### CHANNEL

The trapezoidal channel is more adapted to the flatter land slopes where sufficient fill for the ridge can be obtained from shallow depths of cut. Narrow channels are satisfactory only for small machinery. The flat channel terrace previously discussed has a wide, flat trapezoidal channel designed to accommodate the equipment that is to be used on them. This type channel is adapted to slopes up to around 4 percent.

The V-shaped channel can be used on any terraceable slope. It is more economical to construct than the trapezoidal channel on the steeper slopes. The broad, shallow V-channel is better adapted to larger machinery like 6- and 8-row equipment.

The channel capacity should be adequate to handle the runoff from a 10-year frequency, 24-hour storm.

#### ALLOWANCE FOR FREEBOARD

The 1.0-foot height for a V-channel section used in the previous illustrations was measured from the bottom of the V-channel to the peak of the terrace ridge. Most specifications do not allow measuring in this manner for the effective height of a terrace.

For example, it may be specified that the net height will be measured from the 3-foot width on both the channel and the ridge as shown in Figure 8-18.

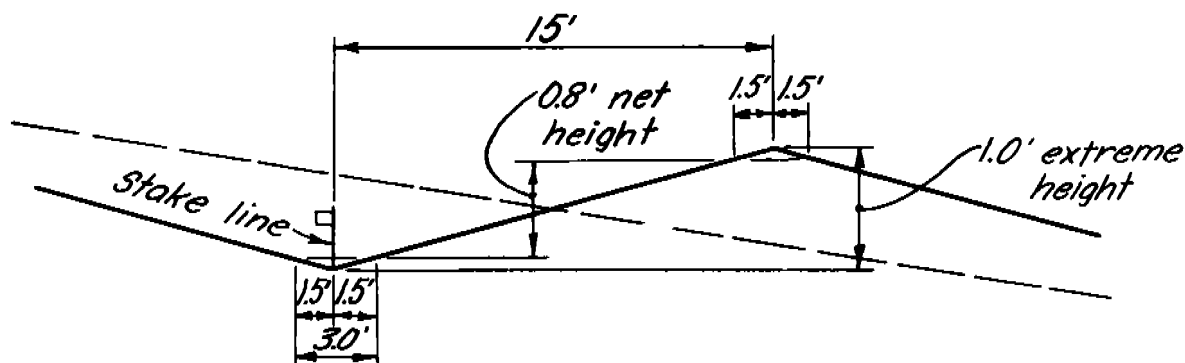

Figure 8-18 Cut measured from 3-foot width on channel and ridge

If this is the case, then the net height would be 0.8 foot. Net

$$\text{Net height} = 1.0 \left( \frac{15 - 1.5 - 1.5}{15} \right) = 1.0 \left( \frac{12}{15} \right) = 0.8 \text{ foot}$$

#### 6. TERRACE SPACING

Terrace spacing depends mainly upon land slope. However, it also depends upon the soil and climate. The cross section will have some effect on the horizontal spacing. The crops to be grown and the machinery that will be used should also be considered.

Terrace spacings for various slopes, soils, and management conditions are prescribed in the Work Unit Technical Guide.

Terrace spacing is determined by either of two methods. One is by using the equation  $VI = XS + Y$ . The other is by applying the Universal Equation for predicting soil loss.

TERRACE SPACING EQUATION

The equation  $VI = XS + Y$  gives the maximum vertical spacing. In this equation:

VI = vertical spacing in feet

X = a variable with values from 0.4 to 0.8 for graded terraces, and 0.8 for level terraces

S = land slope in feet per 100 feet

Y = a variable with values from 1.0 to 4.0 as influenced by soil erodibility, cropping systems, and crop management practices

The "X" value in the equation is a variable which is determined by the geographical location of the terraces. It is largely dependent upon the quantity and intensity of precipitation in the general area. Figure 8-9 gives recommended values for gradient terraces in any specific location.

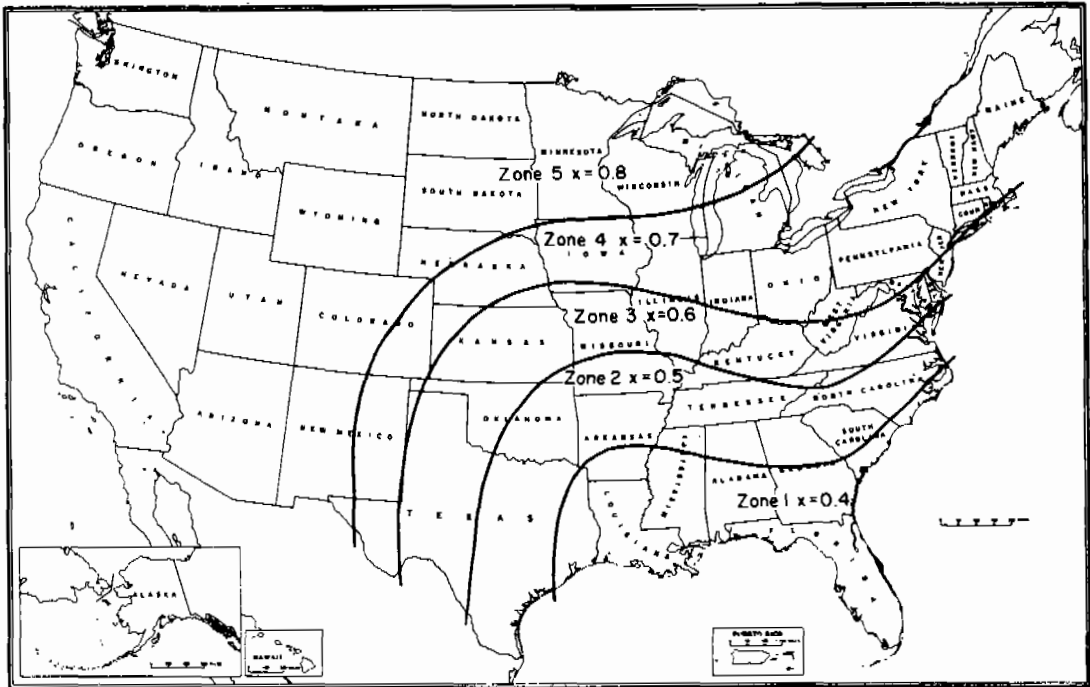

Figure 8-19 Values of X in Equation  $VI = XS + Y$

The values of Y generally used are as follows:

Y = 1.0 for soils with below average intake rates and cropping systems that provide little cover during intense rainfall periods

Y = 4.0 for soils with average or above intake rates and cropping systems that provide good cover during periods of intense rainfall

Y = 2.5 where one of the above factors is favorable and the other unfavorable

Terrace spacings usually have been determined vertically using a vertical interval formula with the predominant slope between terraces. The terraces were then spaced a vertical distance apart. Usually there was no attempt made to determine horizontal interval.

With parallel terraces the horizontal interval is important in order to fit equipment and trips through the field. The vertical interval is used only as a means to determine horizontal interval. The vertical interval equation  $VI = XS + Y$  can be arranged to determine the horizontal interval.

For example, if the value of X is 0.7 and Y is 2, then the equation becomes  $VI = 0.7S + 2$ .

The equation can be arranged to determine horizontal interval.

$$HI = X(100) + \frac{Y(100)}{S}$$

For the above case of X and Y, the equation for horizontal interval

$$HI = .7(100) + \frac{2(100)}{S} = 70 + \frac{200}{S}$$

If the slope is 8 percent, then the  $VI = 0.7(8) + 2 = 7.6$  feet, and the

$$HI = 70 + \frac{200}{8} = 95 \text{ feet}$$

### UNIVERSAL SOIL LOSS EQUATION

This equation can be used to determine terrace spacing in areas where the necessary data are available. However, the horizontal interval cannot exceed the slope length determined for contour cultivation by using the allowable soil loss, the most intensive use expected for the land and the expected level of management. The Universal equation is  $E = KRCSLP$ , which, when used for terrace determination becomes

$SL = E/KRCP$ , where

L = Slope length factor

S = Land slope factor

E = Allowable soil loss in tons per acre per year

K = Soil factor

R = Rainfall erosion factor

C = Cropping management factor

P = Mechanical practice factor

Example: Determine terrace spacing for a 7 percent slope for  $E = 5.0$ ,  $K = .32$ ,  $R = 190$ ,  $C = .24$  and  $P = .45$ .

Then  $SL = 5 \div (.32 \times 190 \times .24 \times .45) = .76$ .

The equation to calculate the horizontal interval (HI) when SL has been determined is:

$$SL = \frac{\sqrt{HI}}{100} (0.76 + 0.53S_1 + 0.076S_1^2) \text{ or}$$

$$HI = \left[ \frac{100 SL}{0.76 + 0.53S_1 + 0.076S_1^2} \right]^2$$

where "S<sub>1</sub>" is land slope in percent - in this case (S<sub>1</sub> = 7)

$$HI = \left[ \frac{100 \times 0.76}{0.76 + 0.53 \times 7 + 0.076 \times 7^2} \right]^2 = 86.5 \text{ feet}$$

The above factors, if available, may be found in the SCS Work Unit Technical Guide.

#### SPACING AFFECTED BY CROSS SECTION

The effective cultivated length of slope between terraces varies with the type of cross section. The back slope of the broad base cross section can be cultivated and therefore is a part of the effective length. This then is not true of the grass back slope cross section because the steep back slope cannot be cultivated. The front slope of either section does not contribute to the effective length. Therefore, terrace spacing can be increased by the horizontal length of the back slope when the grass back slope section is used.

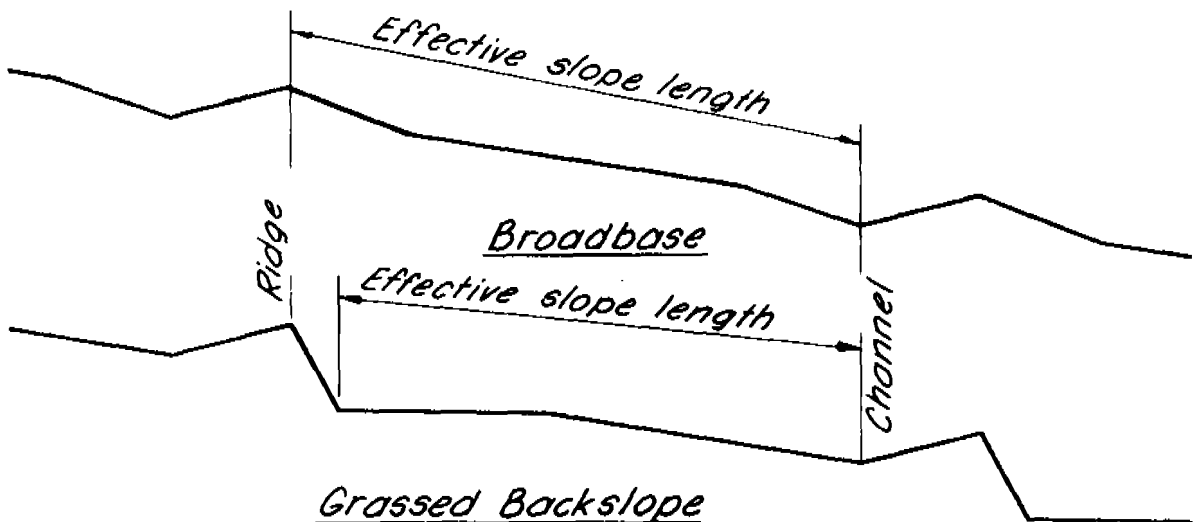

Figure 8-20 Spacing affected by cross section

SPACING ADJUSTED FOR MACHINERY

If the terraces are parallel but are not spaced to fit the equipment used on them, they are not as farmable as they could be. If the common equipment is 4-row with 40-inch row spacing, then terraces should be planned on multiples of 13 ft. 4 inches. They will be more farmable yet if planned on round trips of the equipment, in this case, multiples of 8 rows, or 26 ft. or 8 inches. The front slope should have a width that will fit the farm equipment.

The following indicates conditions to be considered in spacing terraces. The trend for corn is to 30-inch rows and to 6- and 8-row equipment. One trip through the field takes either 15 or 20 feet. Many farmers are changing to 30-inch equipment, especially for the gentle slopes. Four-row, 40-inch equipment is being used on the steeper land but it will undoubtedly be replaced by 30-inch equipment, probably 6-row. In any event, the equipment being used and to be used should be considered in each layout. If the technician plans a spacing which will accommodate several row spacings, the system will be more flexible and much more valuable. If two different row crops with different row spacings are planned in rotation the layout should accommodate both row spacings.

Table 8-1 Terrace spacing for 30- and 40-inch equipment

40-inch Width rows		Distance (feet)	30-inch Width rows		
Number of rows	Trips - 4-row		Number of rows	Trips - 6-row	Trips - 8-row
18	4+	60	24	4	3 $\frac{1}{2}$
22 $\frac{2}{3}$	5+	75	30	5	--
24	6	80	32	--	4
28 $\frac{3}{4}$	7	90	36	6	--
30	7+	100	40	--	5
32 $\frac{4}{5}$	8	105	42	7	--
36	9	120	48	8	6
44 $\frac{5}{6}$	11	150	60	10	--
48	12	160	64	--	8
56 $\frac{6}{7}$	14	180	72	12	9
72	18	240	96	16	12

A trip means once through the field.

- 1/ It is not anticipated that 8-row 30-inch equipment will be used on land which is 10 percent and steeper, nor on terraced land with spacings less than 80 feet.
- 2/ Leave an extra 4 inches between trips to increase the spacing from 73.3 to 75.0 feet.
- 3/ Save 7 inches between trips to decrease the spacing from 93.3 to 90 feet.
- 4/ Save 3 inches between trips to decrease the spacing from 106.7 to 105.0 feet.
- 5/ Leave an extra 4 inches between trips to increase the spacing from 146.7 to 150.0 feet.
- 6/ Save 6 inches between trips to decrease the spacing from 186.7 to 180.0 feet.

Table 8-1 shows possible terrace spacings which will fit 30- and 40-inch row equipment. Some adjustments are necessary and these have been made on the 40-inch rows because there is more flexibility with the 40-inch row pattern. First of all it takes more trips (one pass through the field) with 4-row, 40-inch equipment than it does with 6- and 8-row, 30-inch equipment. The only place to adjust is in the spacing between trips, thus the more trips between terraces the more opportunity to adjust. Secondly, 40-inch rows can be narrowed 6 to 8 inches without difficulty. This is not feasible with 30-inch rows, considering the equipment and the width of tractor tires. It should be noted in the table that the 120-foot spacing fits all the equipment shown.

## 7. ALIGNMENT

Alignment is probably the most important factor in terrace farmability and acceptance. Terraces should be parallel wherever possible for row crops. When this is not possible due to topography or other reasons they should be laid out with the best possible alignment. When all the terraces in a field will not lay out parallel, divide the system up into groups of parallel terraces. Generally, terraces which are straight or nearly straight with gentle curves are easiest to parallel and to farm. Likewise terraces which have many curves, sharp curves, and reverse curves are difficult to parallel and more difficult to farm.

On short slopes or fairly regular slopes all terraces can be made parallel if soil conditions permit. On long slopes or irregular slopes it may not be possible to do this. Correction areas may be necessary, but these areas can be concentrated between groups of parallel terraces. They can be planned as to width so that they also will fit the farm equipment.

### CORRECTION AREAS

Correction areas warrant detailed study to provide the best farmable terrace system. There are two general considerations to be kept in mind:

1. Confine corrections to the area between groups of parallel terraces.
2. Use one large area instead of several smaller ones.

If a correction area is small and narrow, do not correct at this point. Rather, adjust one of the sets of parallel terraces to eliminate the small correction area. This will have one of two effects. It may eliminate the correction area entirely as the group is adjusted down the slope or it will result in a wider and more usable correction area.

Generally farmers tend to plow and plant the whole field including the correction areas. When the correction areas are farmed it is necessary to turn on the crop and thus cause some damage. Correction areas can be left in grass, or portions of the area left in a grass turn strip to eliminate turning on the crop. If a small, narrow correction area is necessary it should be left in grass.

Long, narrow correction areas, as well as short, narrow areas, are very difficult to farm, especially during cultivation and harvest. Therefore the more small areas that can be concentrated into large areas the better the system will be for farming.

On fields which have major changes in slope from one end to the other, the horizontal spacing between two terraces may have to be adjusted in order to stay with the approximate contour. For example, the spacing may change from 24 rows at one end to 32 rows at the other. Here the change fits 4-row equipment as it accounts for one round trip of extra rows. An example of this is shown in Figures 8-79 and 8-80.

### POINT ROWS

Keeping point rows out of the terrace system is one of the main aims in layout. It is not always possible to eliminate point rows. But if the number can be reduced to the fewest possible the terrace system will be more farmable.

Several methods of planning to eliminate point rows or to confine them into large correction areas, have already been discussed. However, one important factor regarding point rows should be kept in mind. Point rows introduced into a system at one point usually will cause complementary point rows at two other locations. Generally, terrace lines are fairly smooth and straight at the top of a hill. Likewise, they are fairly straight along the base of a hill. Usually, the line at the top of a hill will be fairly parallel to the line at the base of the hill. The simplified illustration in Figure 8-21 shows a 3-terrace layout and what happens if a line between the top and the bottom has a sharp curve in it.

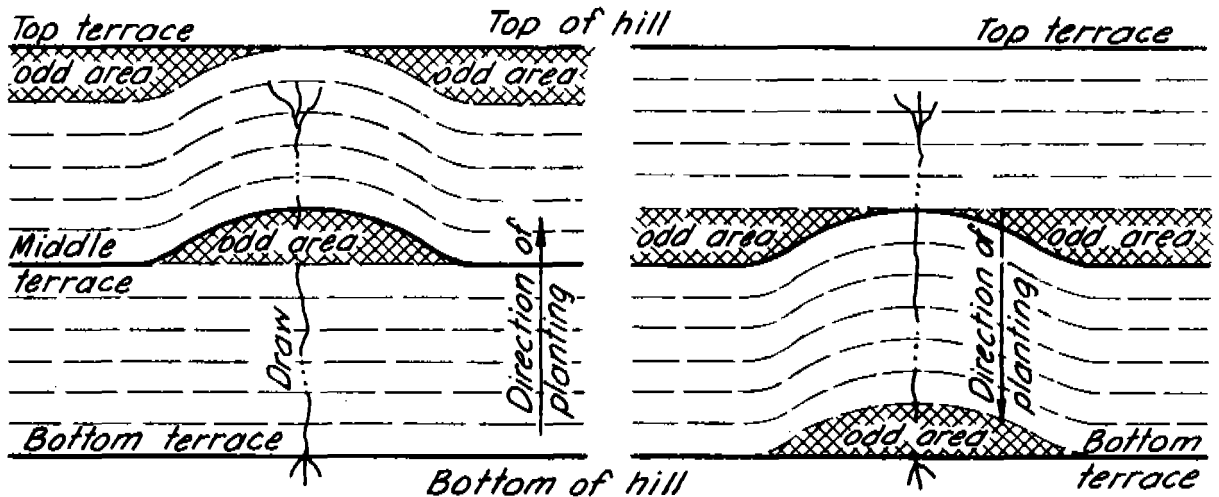

Figure 8-21 Effect of curve between two straight terraces

Figure 8-21 shows the point rows which would occur if the planting is made in an uphill direction. Also, if the planting is made down from the top, there will still be like sets of short rows. Again, this shows that point rows introduced into a system at one place usually cause point rows at two other locations.

In the above illustration about the only solution would be to fill across the depression to straighten out the middle lines. This might be a good location for a tile outlet.

### GENERAL GUIDES FOR PARALLELING

There are several methods or guides available for paralleling terraces. Often a combination of these methods is necessary to make a group of terraces parallel.

#### Cut and Fill Along the Terrace Line

This is one of the best methods of improving alignment. It simply means cutting at the high points and filling at the low points in order to keep the alignment straight or smooth. It works well on the flatter topography, as small cuts and fills will allow the lines to be made parallel. It works with all types and cross sections of terraces. The terrace can be made to go straight across the smaller depressions and draws. See Figure 8-22. A method of cut-and-fill design is discussed under the section on design.

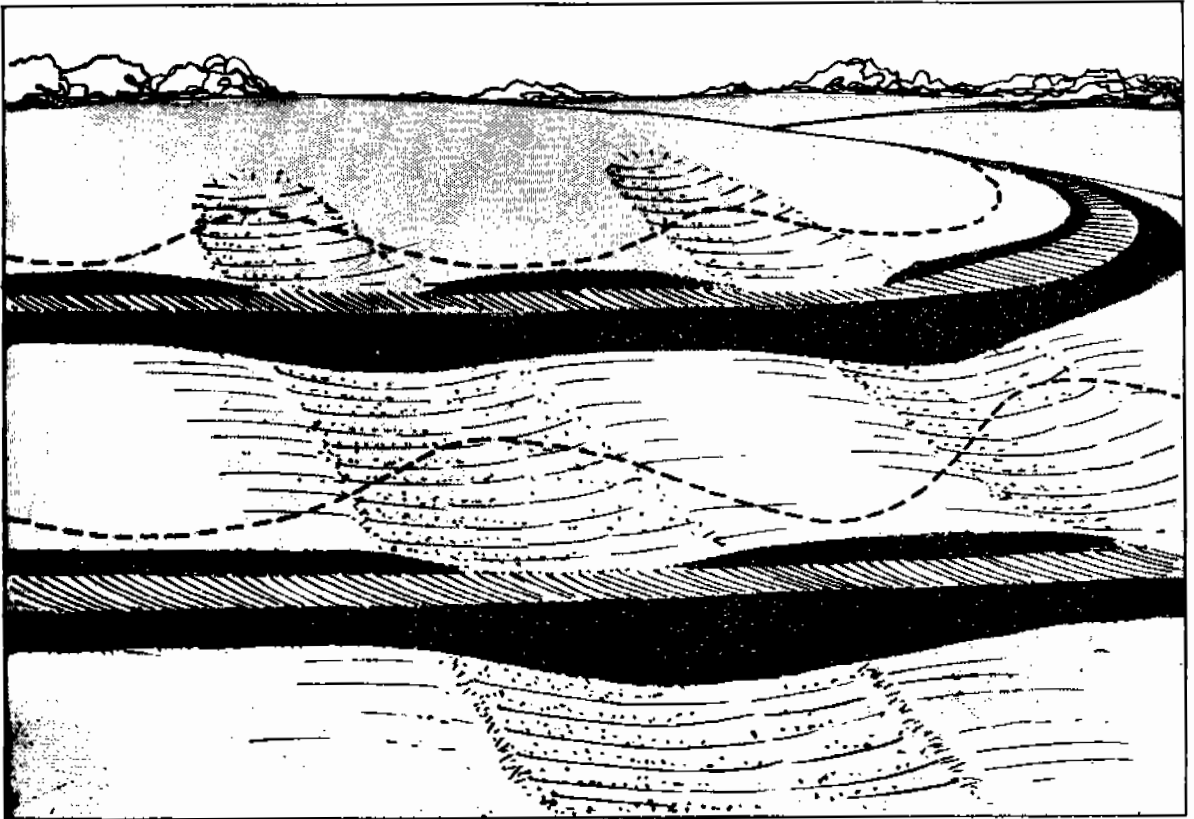

Figure 8-22 Making terraces parallel by cutting and filling  
(dashed lines show where standard terraces  
would have been)

Cutting and filling have other advantages. The terrace grade can be increased by cutting at the lower end and filling at the upper. Grade can be decreased by filling at the lower end and cutting at the upper. See Figure 8-23. The grade also can be made uniform by cutting and filling. Waterways and grass turn strips can sometimes be eliminated by using the cutting and filling procedure.

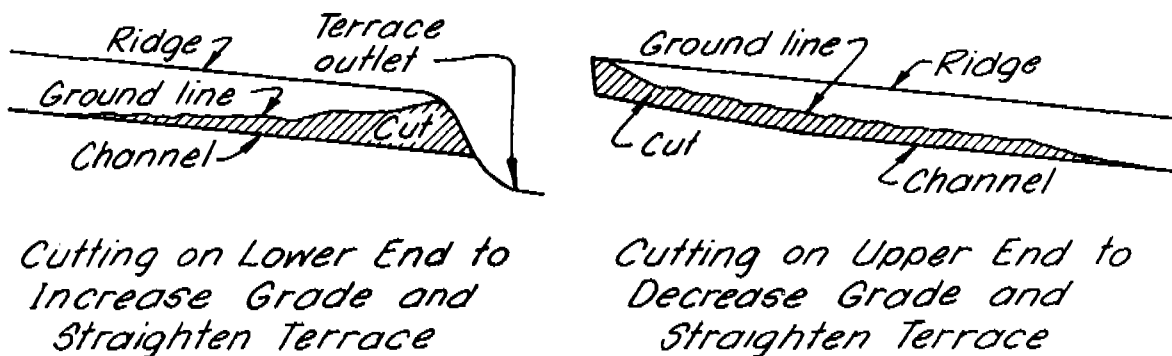

Figure 8-23 Increasing and decreasing grade by cutting

There are limitations to consider in cutting and filling. Terraces cost more when earth has to be moved along the terrace line. Deep cuts may expose subsoil with unfavorable characteristics. However, stockpiling topsoil and respreading it after construction will offset this disadvantage.

#### Varying the Grade Along the Terrace

For gradient terraces this is a very useful method which does not increase the cost of the job. It is particularly adapted to uniform cross-section terraces on the flatter uniform slopes. Grade can be steepened at the upper end where the drainage area is small. Grade can be flattened anywhere along the line.

By using the flattest grade allowable on some terraces and the steepest grade allowable on others, terraces can be shifted in their positions so they will be parallel. If necessary, the top terraces can sometimes be made to discharge at one end of the field and the lower terraces at the other end. However, terrace grade should not be increased to the point that erosion will occur in the channel. Likewise, the grade should not be flattened to the point that poor drainage or excessive deposition of sediment will result.

#### Divide Terrace into Short Segments

This is an important and economical method for paralleling terraces or improving alignment. Briefly, it means leaving more openings, at waterways and on ridges. Refer to Figure 8-24.

Where terraces are divided into shorter segments, there are several advantages. Since the sections are short, the grade can be varied to allow more flexibility in layout. Less cut and fill will be needed. Thus, more terraces can be made parallel. Equipment can be turned on grass at ridges

and field boundaries instead of turning in cropland. And, the grassed areas other than waterways provide travel roads for equipment.



Figure 8-24 Divide into short segments using all the waterways (Dashed lines show where standard terraces would have been)

### Waterways

Use all the waterways and draws as outlets for gradient terraces if necessary to obtain parallel lines, outletting terraces into either a waterway or an underground outlet. Where surface outlets are used, build additional waterways or deepen existing ones if necessary. As a general rule do not carry water past waterways of any size. If large waterways are crossed sharp curves may result and make paralleling difficult. See Figure 8-25.

### Ridges

As a general rule do not carry water around ridges. If the ridge is narrow (sharp) the terraces usually should be left open at the ridge and a grass turn strip used. This removes the need for sharp curves on the ridge which are difficult to parallel or farm. It also makes for a shorter, straighter terrace and one which is easier to parallel. The grass strip should be wide enough so that the terrace can come straight into the strip and all turning of equipment can be done on the grass strip. See Figure 8-26. Grass strips on the ridges provide an ideal location for farm roads.

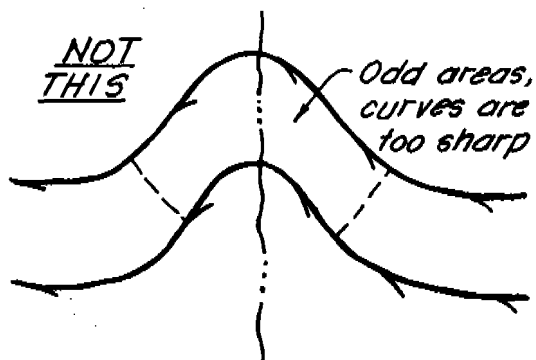

*Terrace Graded Past the Waterway*

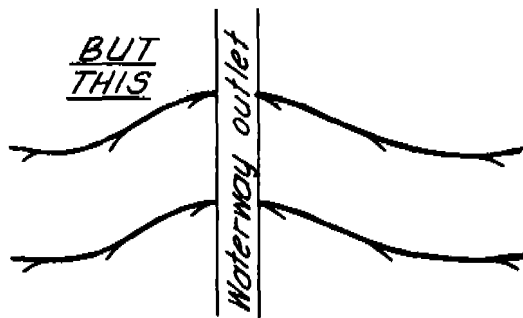

*Waterway Used as Outlet*

Figure 8-25 Right and wrong layout at waterways

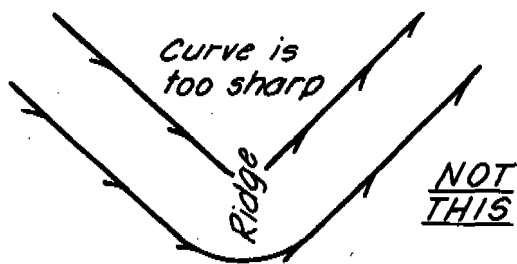

*Terrace Graded Around Ridge*

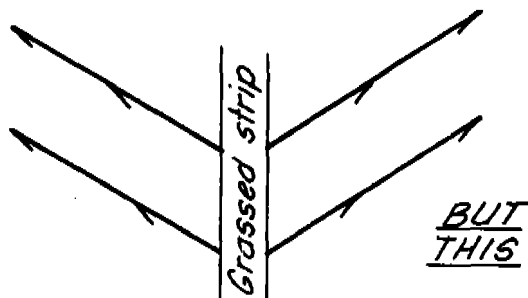

*Terrace Graded From Ridge*

Layout at ridges

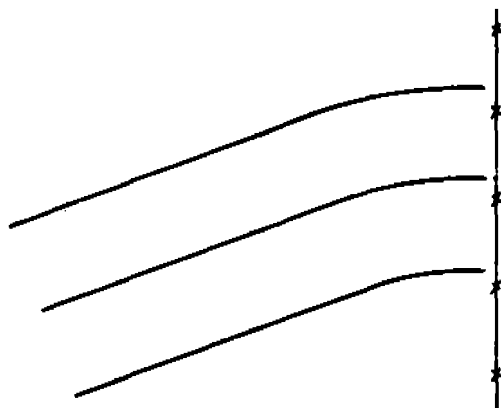

*Terraces Curved to Approach Fence as Nearly Perpendicular as Possible*

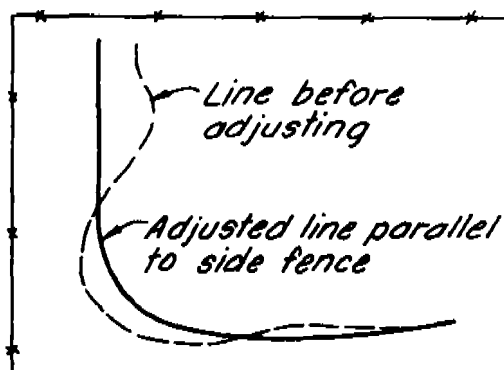

*End of Terrace Made to Parallel Fence*

Layout at field edge

Figure 8-26 Layout at ridges and edge of fields

### Layout at Edge of Fields

Terraces should approach the edge of a field at nearly right angles to facilitate turning farm equipment and help in cultivating. In some cases, a small adjustment can make the terraces parallel the property line and eliminate odd areas and short rows. See Figure 8-26.

It is often desirable to leave a turn strip between the end of the terrace and the field boundary. Turning usually destroys the crop growing near the field boundary. The grass strip can also serve as a field road.

### GRADIENT TERRACES WITH WATERWAY OUTLETS

Paralleling this type of terrace system generally is more difficult than paralleling graded terraces with underground outlets or level terraces, except on smooth gentle slopes. On rough slopes, the use of all methods available may be necessary to obtain groups of parallel terraces.

Dividing the terraces into short segments is probably the best technique for paralleling gradient terraces with waterway outlets. By using most or all of the available draws for outlets and varying the grade along the terraces it usually is possible to make them parallel.

If these two methods do not give the desired results, cutting and filling along the line will allow more adjustment. This will make the lines straighter and the curves less sharp, which makes paralleling easier. However, the most important use of the cut-and-fill method is on the rougher land. It also can be used to eliminate some of the minor outlets by filling straight across some of the natural waterways.

The following guidelines should be kept in mind. Do not carry water around short ridges. Eliminate sharp curves at such locations by using grass turning strips that can serve as field roads. When curves are necessary, make them long and gradual. If at all possible, eliminate reverse curves. Follow the methods discussed above for making the layout at the edge of fields.

### GRADIENT TERRACES WITH UNDERGROUND OUTLETS

This type of terrace system promotes parallel alignment because terraces can be built straight across the shallow waterways and draws.

The cut-and-fill method is especially adapted to terraces with underground outlets as fills are necessary when depressions are crossed. Cuts generally are needed on the broad ridges, so this provides a natural place for borrow. By crowding the terrace up on the ridges and down in the waterways, lines are straightened and made easier to farm. Varying the grade also will help straighten the lines and reduce the cut and fill.

Leave sharp ridges open. If deep waterways or depressions are encountered, it may be better to develop a grass waterway to prevent a radical change in alignment. The layout at the edge of the field is also important.

Outlets should be developed as necessary to improve alignment. If tile lines have been installed in depressions for drainage, the inlet would add little extra cost. However, the tile line should be checked for excessive velocities that may occur when surface water is added to the line. Installation of a new tile line for an outlet may be cheaper over the years than accepting a poor alignment and a less farmable system.

Sometimes it is possible and advisable to use the two types of outlets for the same terrace, or for different terraces in the system, to obtain the best layout. Also there may be situations where there is too much fall in the terrace line. In these cases the higher sections of the terrace should be designed as a graded terrace discharging into the level or lightly graded storage part of the terrace.

### LEVEL TERRACES

The same techniques used for paralleling gradient terraces can be used with level terraces, except the use of multiple outlets.

Cut and fill along the terrace line is almost a necessity with level terraces if a farmable alignment is to be provided. Since a level terrace has a level ridgetop and should have a reasonably level channel, earth-moving along the line will be necessary whenever the terrace is moved from the original contour line. This practice gives flexibility to the layout and permits more terraces to be parallel.

Leave openings at the sharper ridges. Generally, waterways are crossed by level terraces. However, at the deeply incised waterways, or where two major slopes intersect, it may be better to leave an opening. This is because terraces change directions rather radically at these intersections. These openings promote parallel alignment and, when grassed, can be used in the field road system.

The layout at the edges of fields and near farm boundaries are important also. Oftentimes a small adjustment here will allow parallel rows between the terrace and the fence. The end of the terrace may be either raised or blocked. The raised end is accomplished by raising the terrace line about one foot vertically at the end of the end of the terrace. This usually makes the terrace curve uphill and may make for difficult paralleling because of added short curves. The blocked end is accomplished by carrying the terrace out on the contour, and by building an earth block at right angles across the end of the terrace channel. This usually causes fewer alignment problems. See Figure 8-27.

NOT THIS

*Terrace with End  
Turned Uphill*

BUT THIS

*Terrace Straight with  
Crossable Blocked End*

*Block*



Figure 8-27 Treatment at end of terrace

There is one additional technique that is adapted to only level terraces. It is a design method of dividing the terrace into various levels. The terrace will be continuous but the different levels of ridge and channel are separated by farmable earth blocks. Blocks, large enough to prevent individual rows from draining runoff into the depressed terrace segment, should extend the full terrace interval. Each of the different levels of the terrace should be designed as an individual level terrace, using its own level, even though the terrace is continuous. See Figure 8-28.

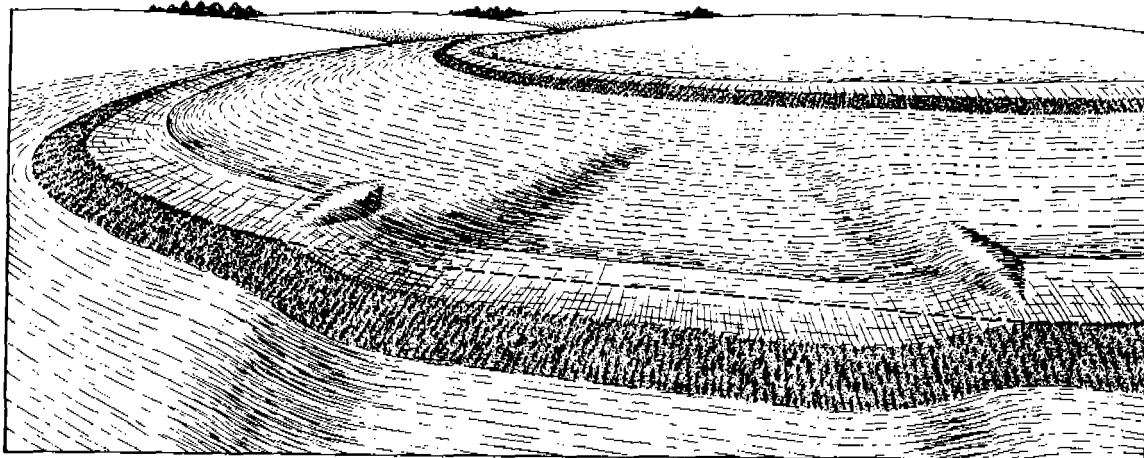

Figure 8-28 Dividing terrace into various levels

This feature promotes parallel alignment; a part of the terrace otherwise would have to be shifted to keep near the contour. This also prevents the excessive earthmoving that would be necessary to bring the entire terrace to one grade. The limitation of this method is that the different levels of the terrace must be separated by earth blocks. These must be maintained, and they are not easy to farm over with large machinery. Therefore, the more gradual the side slopes on the blocks, the easier they will be to farm.

## 8. LAYOUT GEOMETRY

Rather than proceeding right into layout, it is best to first consider some of the geometry of layouts. The geometry involved is not complex, dealing mostly with curves and straight lines, but it is often not recognized in a field layout.

### CURVES

Most terrace systems have curves in them that are either simple or reverse curves. Simple curves are those which curve in only one direction. Reverse curves are two adjacent curves that curve in opposite directions. The reverse curve should be avoided if at all possible.

## Parallel Curves

Each curve has a center. Concentric circles are parallel and have a common center. Concentric curves are portions of concentric circles so they, too, are parallel and have a common center. A perpendicular line drawn from a tangent on a curve will intersect the center and form a radius of each circle. Refer to Figure 8-29.

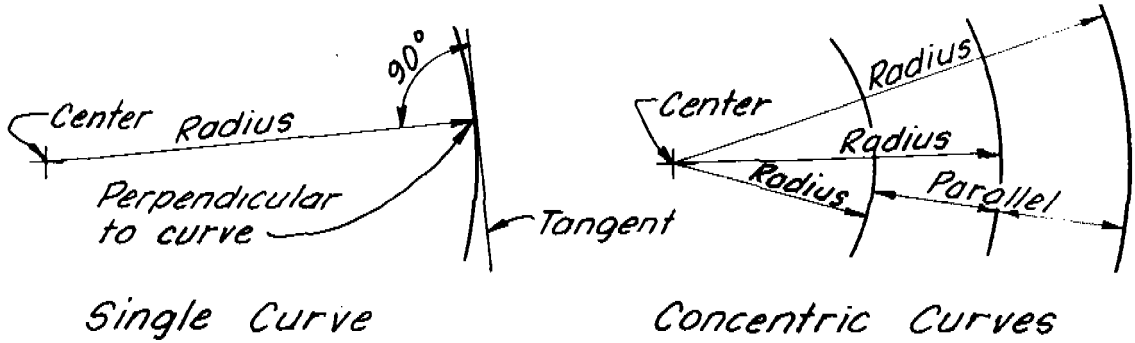

Figure 8-29 Properties of curves

As the center of concentric circles is approached, the curves get sharper. In other words, if a terrace is being planted on the inside of the curve, and planting continues going toward the center, the curve in the rows becomes sharper and sharper.

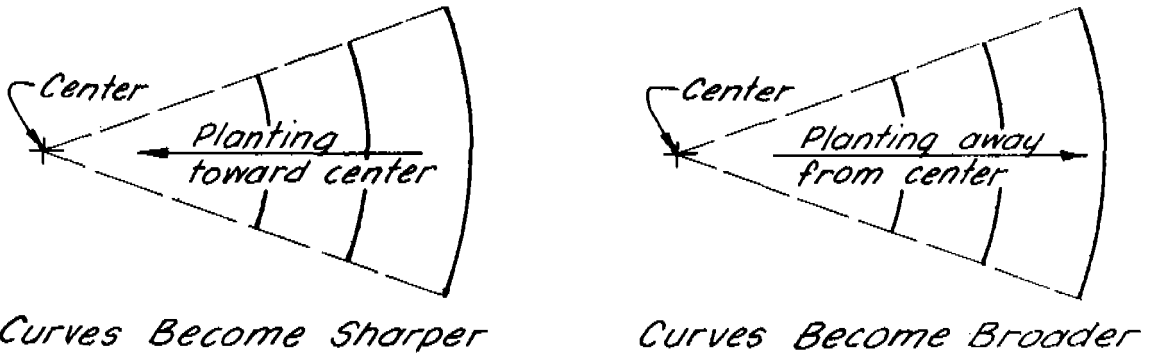

Figure 8-30 Planting on curves

## Identical Curves

Identical curves are curves of the same radius. One could be transposed on top of another and they would be exactly the same. If two adjacent terrace lines are laid out with curves of the same radius, point rows or odd areas will be created. This is most apt to happen on sharp ridges, although it also can happen at waterways. The following figures show this situation.

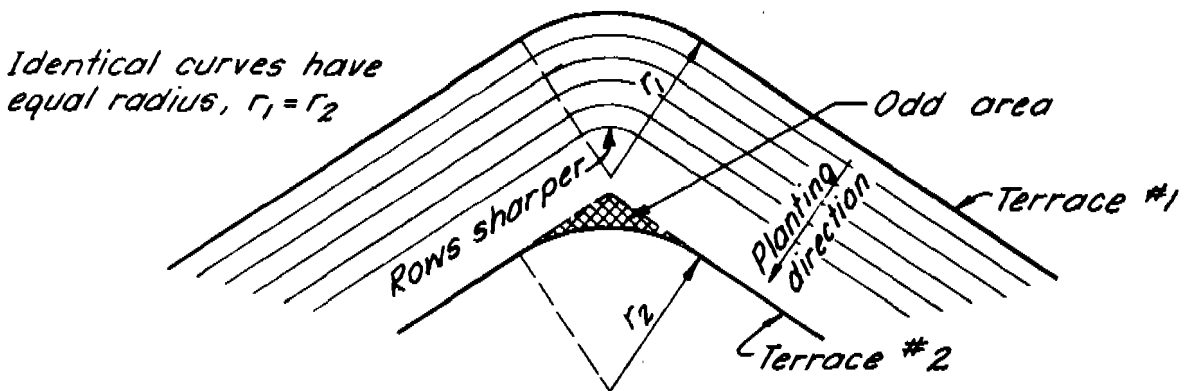

Figure 8-31 Planting toward center of curves

If planting is carried out toward the center of the curves, the rows finally become so sharp that equipment cannot make the turns. See Figure 8-31.

If planted away from the center, the curves become more and more gradual. However, point rows will be necessary at the outside terrace in order to fill in the remaining area. See Figure 8-32.

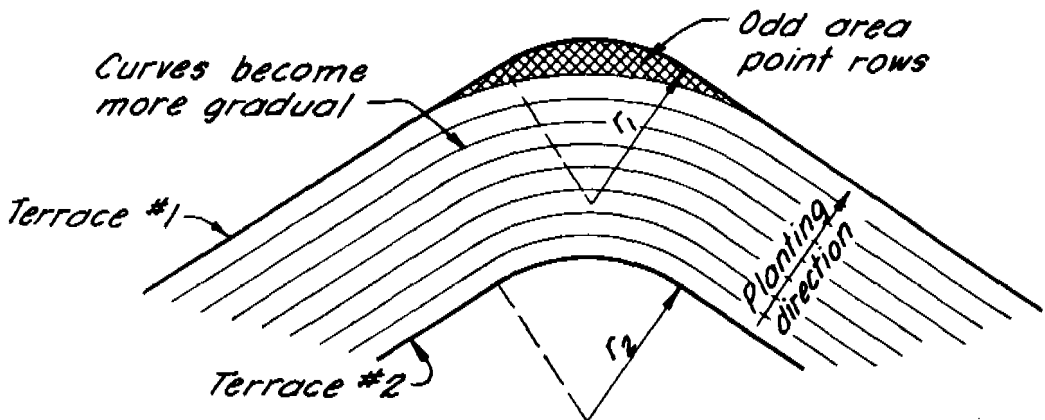

Figure 8-32 Planting away from center of curves

Therefore, where curves are necessary they should not be identical. They should be laid parallel by making them an equal distance apart. They will then be portions of concentric circles with a common center. If this cannot be done, there will be point rows in the layout. Other techniques, described later, may be used to avoid using the curves.

### Reverse Curves

A reverse curve occurs when a line curves first to the right and then to the left, or vice versa. Reverse curves occur quite often in terrace layouts. They should be avoided if possible. In any event, they should be recognized as a problem and given special attention. See Figure 8-33.

They are like the curves discussed earlier, the main difference being that there are two or more of them. Each of the curves has a center. However, with reverse curves, there will be a center on each side of the line. This is the problem. As lines are laid parallel on each side they can only be parallel as far away as the center of the curves.

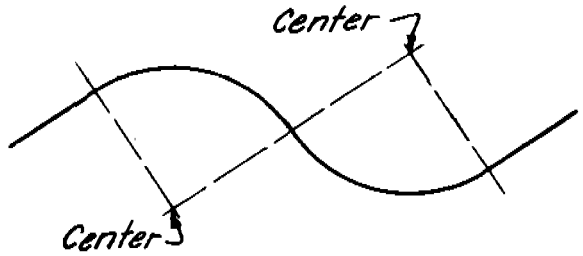

Figure 8-33 Reverse curves

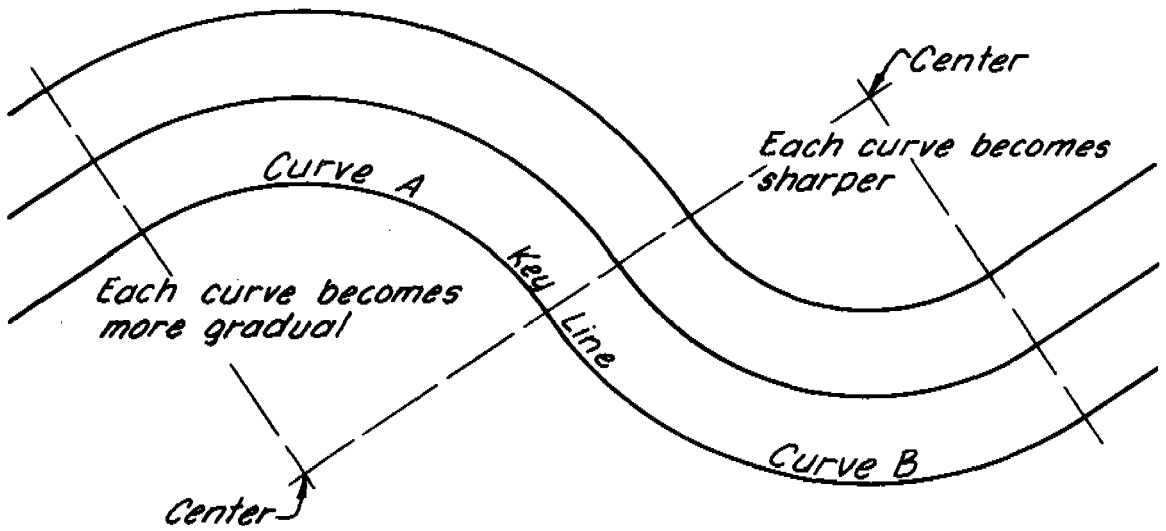

Figure 8-34 Example of reverse parallel curves

In Figure 8-34 it will be noted that the curves above Curve A, become more gradual, and would be easier to farm. In the case of the curves above Curve B, the curves become sharper toward the center. Somewhere before the center is reached there will be difficulty in farming because the curve of the rows will be too sharp. This shows that reverse curves limit the number of lines which can be made parallel on either side of the key line. If reverse curves cannot be avoided they should be planned as gradual curves. This places the center a greater distance away from the line, and should allow paralleling for a greater distance. Refer to Figure 8-35. If the curves cannot be made gradual, a correction area will have to be planned in the system.

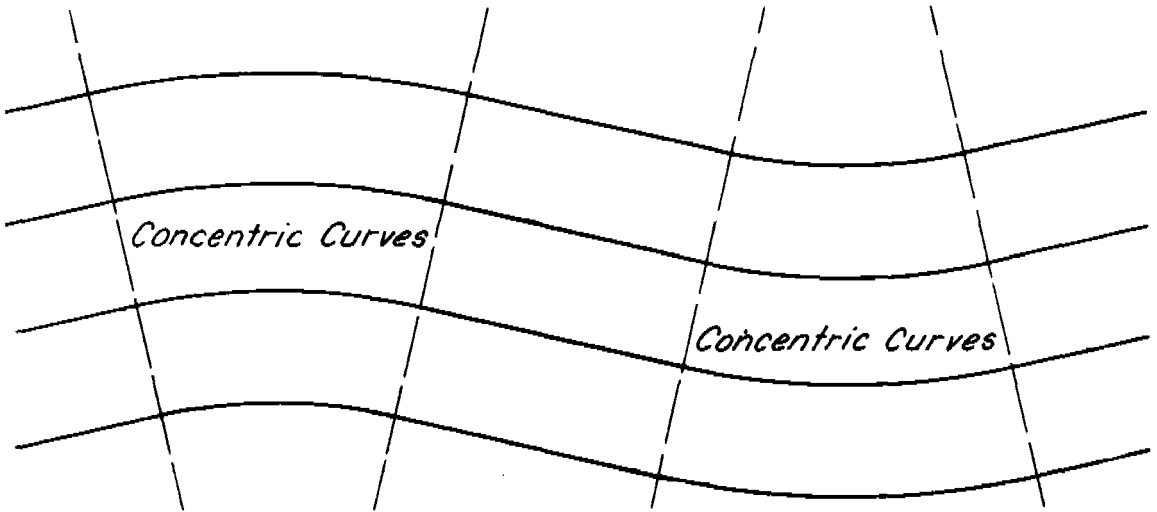

Figure 8-35 Reverse curve made gradual

### STRAIGHT LINES

Segments of terraces will be composed of straight lines. Straight lines are desirable as they are the easiest to parallel and the easiest to farm.

If a terrace line is almost straight when first laid out, there will be an advantage to changing it to a straight line. This will make it easier to lay parallel lines above and below it. This applies to segments of terrace lines also. However, it should be pointed out that this can be carried too far. There is nothing wrong with a long gradual curve, as it can be paralleled quite easily. See Figure 8-36 for adjusting the stake line to a straight line.



Figure 8-36 Changing staked line to straight line

### CURVES AND STRAIGHT LINES

There will be many cases in layout where sections of terrace lines will be straight with curves connecting the straight lines. The point where the straight line meets the curve is the beginning of the curve and is called the point of curve or P.C. Likewise, the point where the curve meets the straight line is the end of the curve and is called the point of tangency or P.T. These are shown in Figure 8-37.

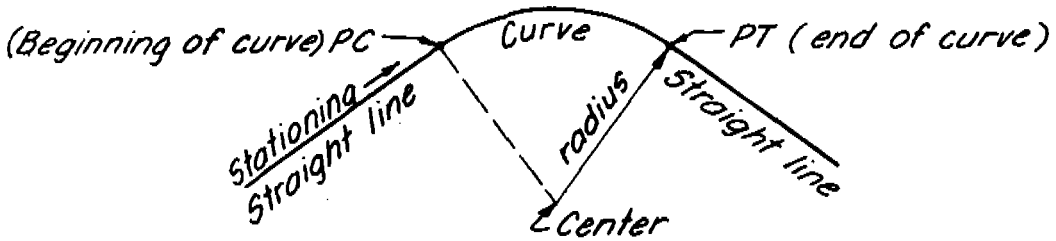

Figure 8-37 Single curve

Concentric curves are parts of concentric circles and have a common center. If straight parallel lines are connected to concentric curves, each line meets at a P.C. or P.T. on each curve. If a line is drawn through the P.C.'s or P.T.'s it will be straight and will, if extended, go to the common center of all the curves. Also, this line through the P.C.'s or the P.T.'s will be perpendicular to the parallel lines. Refer to Figure 8-38.

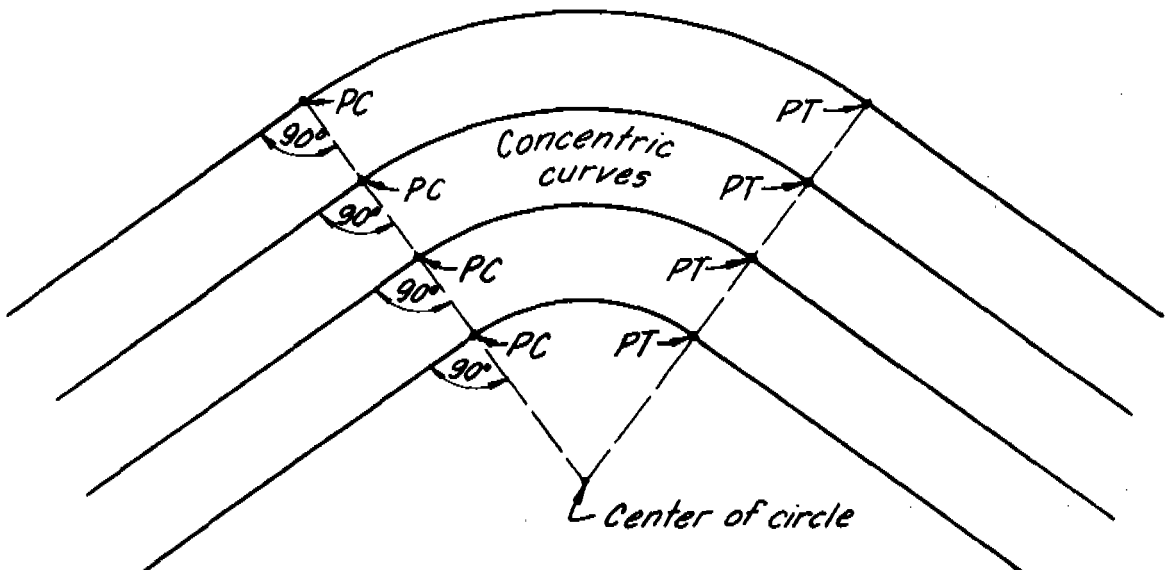

Figure 8-38 Parallel lines and curves

These factors are helpful in terrace layouts where curves are necessary between straight lines. Lining up the P.C.'s and P.T.'s on each terrace line and setting stakes at these points will save time in laying out the straight parallel segments. This will also set the length of each curve and assure that the curves are concentric and parallel.

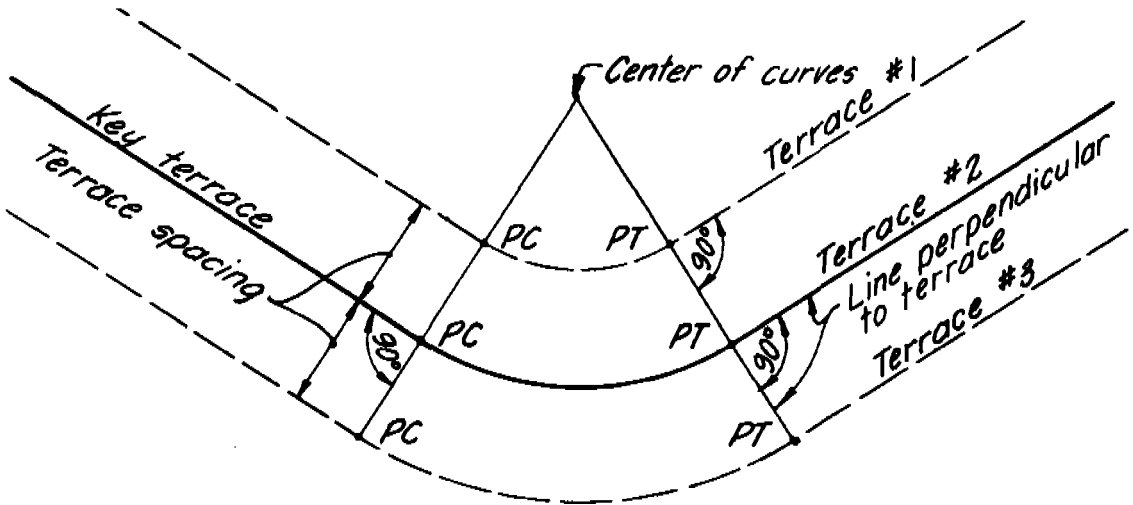

Figure 8-39 Layout geometry

Referring to Figure 8-39, the P.C.'s and the P.T.'s are lined up by laying off a line each way from the key terrace and perpendicular to it. The P.C. and P.T. stakes for terraces 1 and 3 are set on the perpendicular line at the required spacing from the key terrace. The curves on terraces 1 and 3 can then be staked parallel to the curve on the key terrace. It will be noted that the curves become longer and more gradual from terrace 1 to terrace 3. The curve on terrace 1 is the sharpest and it must be checked to see that it is not so sharp as to interfere with cultivating and harvesting equipment.

#### EXTENSION OF PARALLEL LINES

One of the most valuable techniques in parallel terrace layout is that of stopping certain lines and extending other lines. If this is not considered at layout, point rows will generally occur where terraces abut grass strips, waterways and roads. The sketches in Figure 8-40 demonstrate this technique.

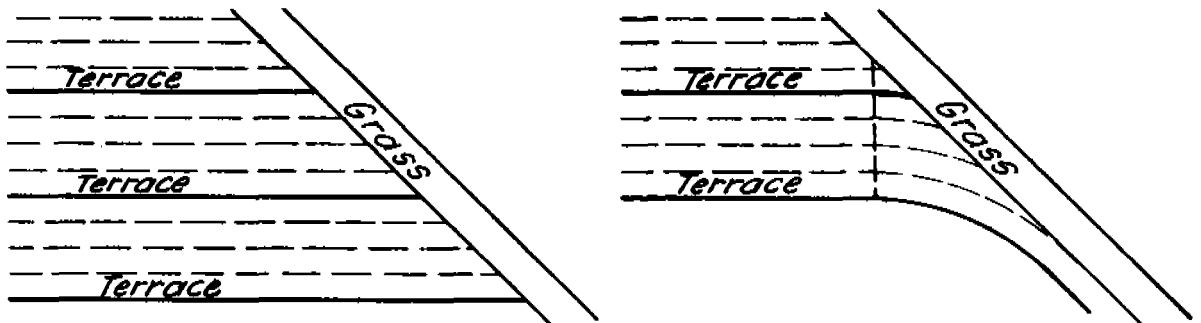

Figure 8-40 Extension of parallel lines

The lines in the sketches are parallel. If the area is properly planted, there will be no point rows. Where one line stops and another line continues, the two need be parallel only until the extension of the perpendicular from the shorter line. This is shown in Figure 8-41.

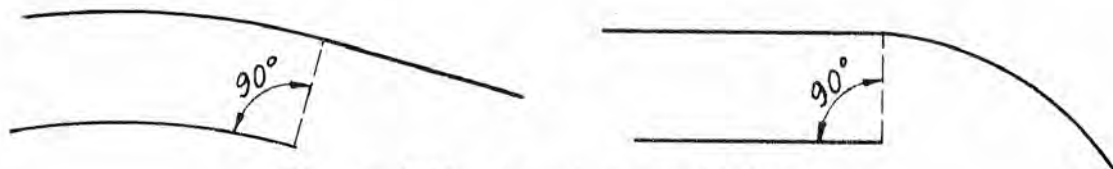

Figure 8-41 Stopping parallel lines

If the technician will be careful in planning the lines and in the use of grassed areas (as turnrows, waterways, or roads) many layouts can be made parallel which would be impossible otherwise. This is especially useful at ends of fields, and at openings at waterways and ridges. This is the only way a sharp ridge can be paralleled.



Figure 8-42 A gentle curve

## 9. LAYOUT

### GENERAL

Before the actual layout is made it is necessary to select the type of terrace system best suited to the field. For gradient terraces it is necessary to determine the type of outlet that will be used. The overall performance of a terrace system often depends on the selection of the location and type of outlet. Natural outlets such as pastures, meadows, rocky drainageways, timbered areas, and wastelands may be so located that part or all of the terraces can be planned to safely outlet on protected areas. The planner should carefully consider all alternatives and select the safest and most economical type of outlet. Refer to the section on Types of Systems. Terrace spacing will depend on the type of cross section selected, the soil type, land slope, crop and machinery. The spacing generally can be selected from the State Terrace Spacing Standard. Specialty crops, such as orchards, will often affect spacing. Approximate field boundaries, field roads and fences should be determined prior to or at the time of layout.

### Terraces in Orchards

The principles and design criteria for the planning of gradient terrace systems on rotated cropland also apply to orchards and vineyards. Tree rows are planted on each terrace ridge and thus the terrace spacing should be a multiple of the tree-row spacing within allowable limits. Where it becomes impractical to construct adjacent terraces parallel to each other, the long or continuous rows should be located parallel to the terraces with the short or point rows located in the center of the terrace interval.

In some areas it is an accepted practice to construct a terrace for each tree row. In such cases the tree-row spacing fixes the terrace spacing, usually at a distance of 25 feet or less. When the terrace spacing is so reduced, a corresponding reduction may be made in the settled cross-sectional area of the terraces, provided they will have a capacity adequate to accommodate the peak runoff that may be expected to result from a 10-year frequency storm without overtopping.

In planning the layout of terrace systems in orchards, careful attention should be given to the location of such roads as are required to facilitate spraying and harvesting operations.

### Farm Roads and Fence Location

Farm roads and fences should be located on natural ridges where terraces crest or on the contour. This will reduce interference with terrace and row drainage patterns and with the construction and maintenance of the terraces. A road layout along the crest of a ridge will often eliminate a sharp breaking curve and facilitate the layout of a terrace system. Another good location for a field road is just below and parallel to a terrace ridge. A road is often used in the interval between two parallel

systems and is located just below the upper terrace so it can also be used as a turning strip. If it is necessary to have a road on one side of the field it should be located so that it will cross on the closures at the closed end of the terraces. Fences or roads should never be located across the outlet ends of rows or terraces. Figure 8-43 shows parallel terrace systems with adjustment strips and an adequate farm road layout for safe and easy entrance to all terraces. Note land use changes to implement good terrace planning and layout.

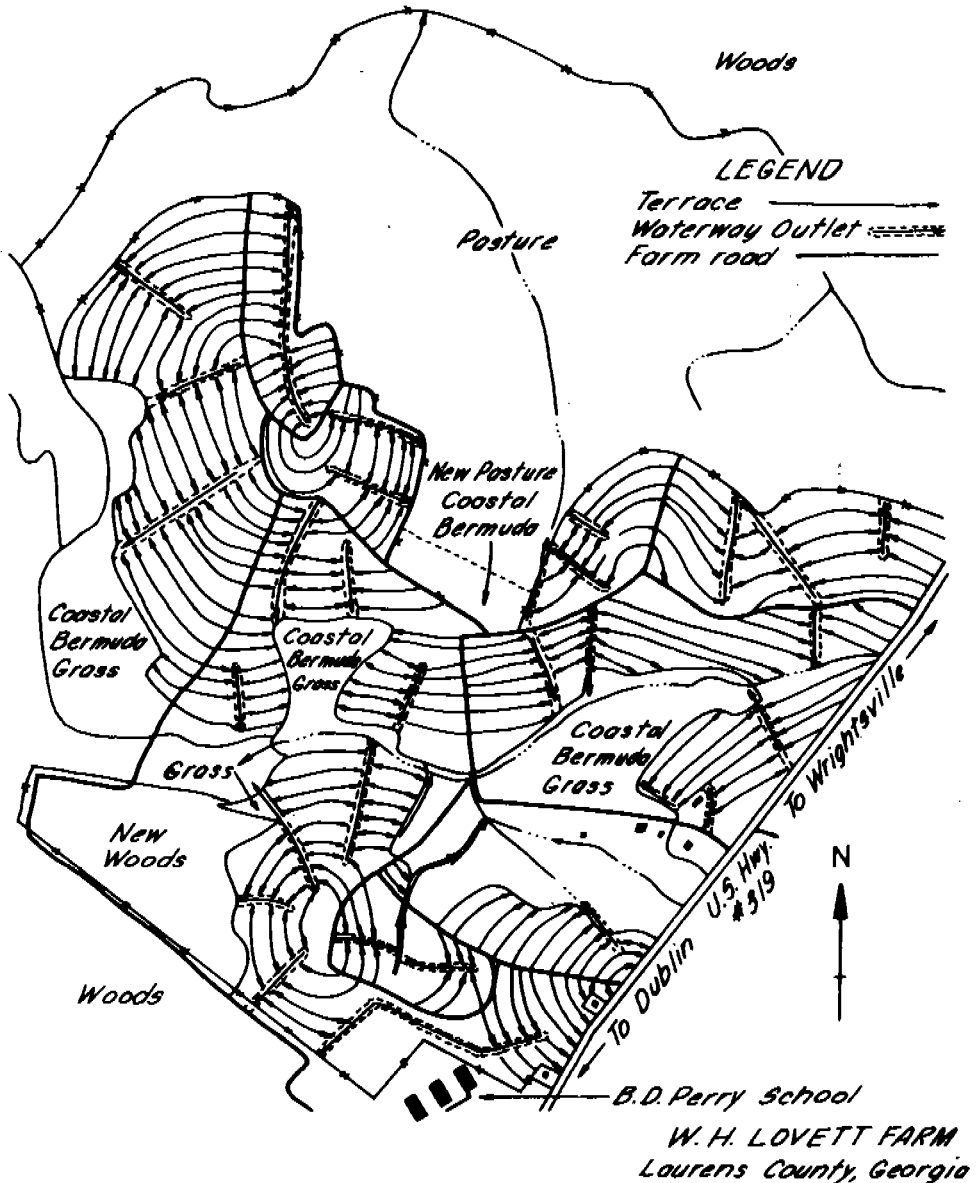

Figure 8-43 Illustration of good farm road layout and land use fitted into a terrace system

### Critical Areas

Critical areas are those with short, usually abrupt, and steep slopes that occur within a terraceable field. They should not be terraced but should be planted to adapted perennial vegetation. Terraces should be located immediately above and below these areas. If the width of a critical area, as measured normal to the terrace lines, is greater than the allowable terrace spacing, a diversion channel should be constructed immediately below the area. The design and construction of diversions is included in Chapter 9 of this manual.

### Preliminary Surveys

The layout of a satisfactory parallel terrace system is more or less a cut-and-try procedure. It is generally necessary to move and adjust the first lines laid out in order to obtain the best farmable system. The amount of adjustment necessary often depends upon the experience of the technician and the topography of the field.

It is helpful to first make a physical inspection of the field. Location of suitable surface outlets can be noted. Waterways that have tile lines should be located. The inspection will show depressions and draws that will require terrace fill. If there are many draws and they are deep it would be best to fill and shape at least the deeper ones prior to layout and construction of the terraces.

Sufficient surveys should be made so that each terrace system can be properly planned. Detailed topographic information must be obtained before the best possible terrace systems can be designed or laid out. On small fields with short uniform slopes and well defined drainageways this information can be obtained from observation, random shots, and trial terrace lines. However, this procedure is time consuming and generally inefficient on large fields with uneven slope changes, slope reversals and many poorly defined natural depressions. These land features create complex terrace system design and layout problems. The use of a topographic map for the complex system or as a training aid for the inexperienced terrace planners will result in higher quality systems with better alignment, fewer point rows and more parallel terraces.

### Topographic Maps

A reasonably accurate topographic map can be used effectively from the early planning stage of terrace system development through final construction. It can be used to work out the best terrace layout, better plan the correction areas, locate the required outlets, and develop the best field road system and turn strips. With a map showing the complete information on the field, the entire layout and how it fits together can be seen. It also allows design of segments of terraces on which corrections by construction may be made to improve alignment or to keep them parallel. Another important advantage is that the designer can explore all alternate layouts without time-consuming efforts in the field. The farmer can select the layout that best fits his needs and desires. The use of topographic

maps permits planning and designing far in advance of construction and at times more convenient to the planner. After the selected layout has been developed, it can be staked in the field according to the paper layouts. Planning with a topographic map has a special advantage when only part of the system will be installed now and the remainder at some later date.

### Types of Maps

A reasonably accurate topography map with good reference points should be prepared so that the paper layout can be easily staked in the field. Topographic maps for terrace planning are generally made by one of the following methods: (Refer to Chapter 1 for survey and plotting information).

Planetable or Transit--Contour lines are located in the field and plotted with planetable and alidade, or elevations of points and their location can be determined by transit and stadia. These points are later plotted in the office and contour lines interpolated. The contour interval depends upon the slope of the field ranging from 2 feet for the flat slopes to 4 or 5 feet for steeper slopes. Running a contour line and plotting it in the field is best adapted to steep, irregular slopes.

Grid Survey--This method is particularly adapted to the more even, flat topography but can be used on most slopes. It is easier to make with less equipment and gives an accurate map if care is used in interpolating the contour lines. With the grid it is easier to reference in the gridlines for transfer of the paper plan to the ground.

Stereo-Photogrammetric Plotting--This method saves on technical time and is probably the most economical way to obtain topographic maps for a large area where there are numerous requests or needs for terraces. Low altitude aerial photography is needed either for 2- or 4-foot contours usually used for terrace planning. Contour lines are then located by either a Kelsh or some other type of plotter. By using adequate control points the paper plan can be satisfactorily transferred to the field. These maps are adapted to any topography. Scheduling is important, as there are several steps necessary to develop Kelsh maps so it is best to plan on getting the maps in the fall, making the designs over the winter for layout the following season. It is best to be somewhat generous in requesting photography, in other words photograph adjoining areas though there is no apparent need on hand. Photography is a small part of the total costs, and ground control and plotting can be deferred until needed.

### Planning with Map

Using the contour map, determine the design slope and terrace interval. Where practical, use the same spacing for all terraces in the field or for groups of terraces. Locate probable outlets and roads. Then lay in terraces to best fit the topography.

It is a good idea to place a plastic acetate sheet large enough to cover the field over the topographic map with the rough side up. The use of the plastic sheet will allow lines to be drawn and erased at will without damaging the design sheet.

Templates made from plastic sheets about 10 x 12 inches with parallel lines drawn on the sheets for different terrace intervals will assist the designer in fitting the terraces to the contours. It can be seen how many terraces can be made parallel before shifting to another group. Adjust templates to give what appears to be a satisfactory grade for the first segment of the flattest terrace and determine if the grades of the other terraces are satisfactory. If not shift template and recalculate. Use another template to extend lines for another segment in the same manner. Join the two segments with proper curves if necessary. Continue process until the end of terrace is reached. Select a template line as a guide-line and be sure it can be referenced to the ground. With a pin or other sharp instrument mark a point through the template on each segment of the line and points of intersection. Then mark beginning and intersection of the other lines and draw the terraces on the plastic overlay. Elevations or rod readings can be calculated for all terrace lines where they cross gridlines. Transfer the terrace lines and elevations, location of outlets, turn strips and roads to the contour map when the system is completed to the designer's satisfaction.

Figure 8-44, sheet 1 of 2, is a grid survey of a field for use in parallel terrace system design and layout. Note location of grid stakes, rod readings, contour lines, reference points and other features. Sheet 2 of this figure shows a graded parallel terrace system with waterway outlet developed from the grid survey map in sheet 1.

Figures 8-45 and 8-46 are examples of terrace planning using topographic maps. Figure 8-45 shows groups of parallel terraces using tile outlets. Note correction areas. The parallel system shown in Figure 8-46 uses both tile and waterway outlets and has a well planned road system.

#### Field Layout from Map

The terrace system plan recorded on the topographic map can easily be transferred onto the land by using horizontal and vertical controls, if sufficient field references are established during the survey. When the landowner is ready to construct the terraces the technician, using the map locations and reference points, physically lays out key terraces on the ground. This is usually done by measuring from the key points with a minimum of actual survey instrument time. This line is checked and compared with design grades. The other terraces are staked above and below the key terrace at the determined interval.

Care must be exercised in staking the terrace lines so that they are equidistant at all locations for parallel terraces. This is generally done by one of two methods.

1. A tape, rope or similar apparatus equal in length to the horizontal spacing can be used if sufficient measurements are made and if care is taken to be accurate.
2. Spacing of terraces is planned for the farmer's equipment so a more accurate method is to use the farmer's tractor for marking terrace lines. The key line is first followed by the farm tractor

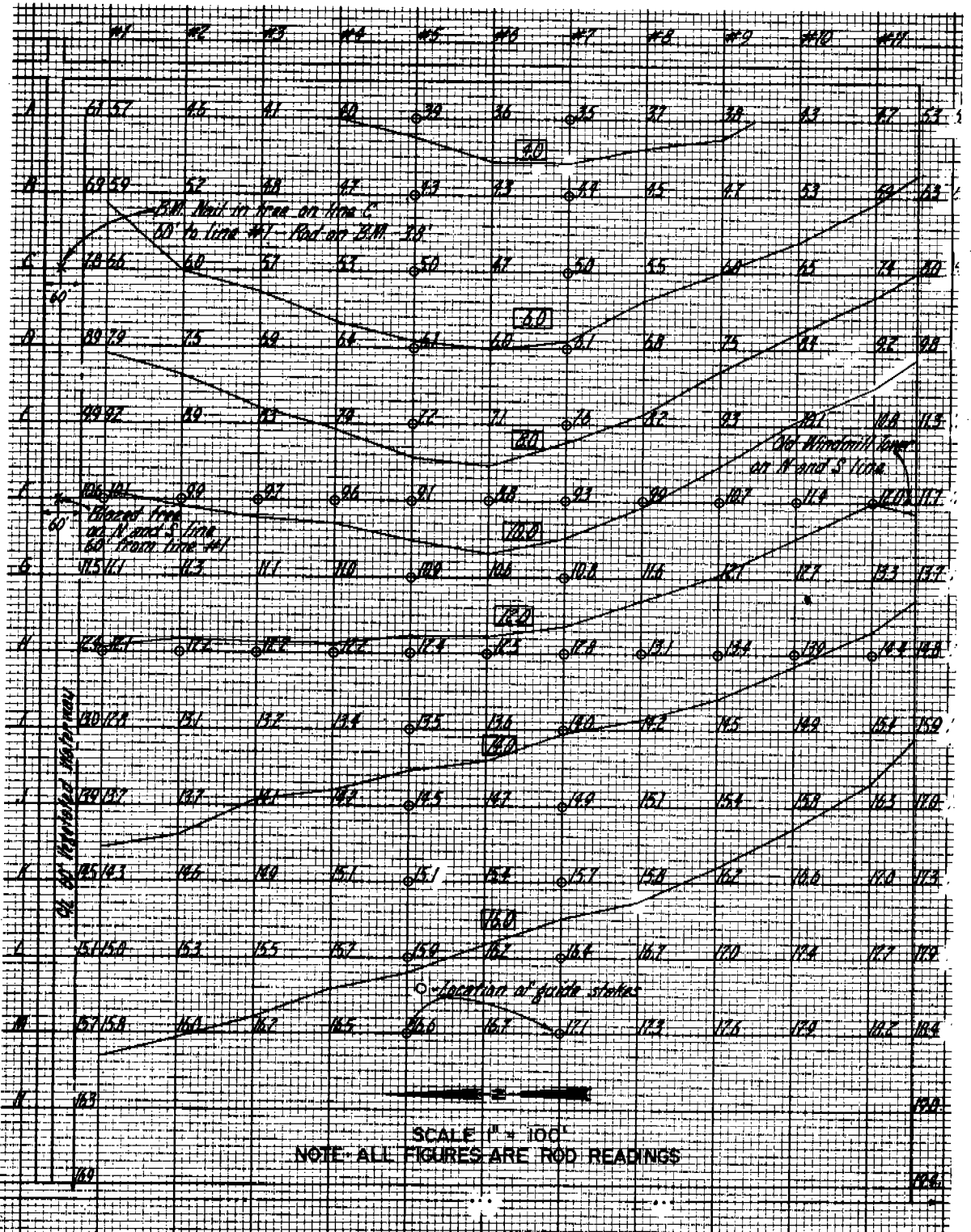

Figure 8-44 Grid survey map for use in parallel terrace system design and layout (Sheet 1 of 2)

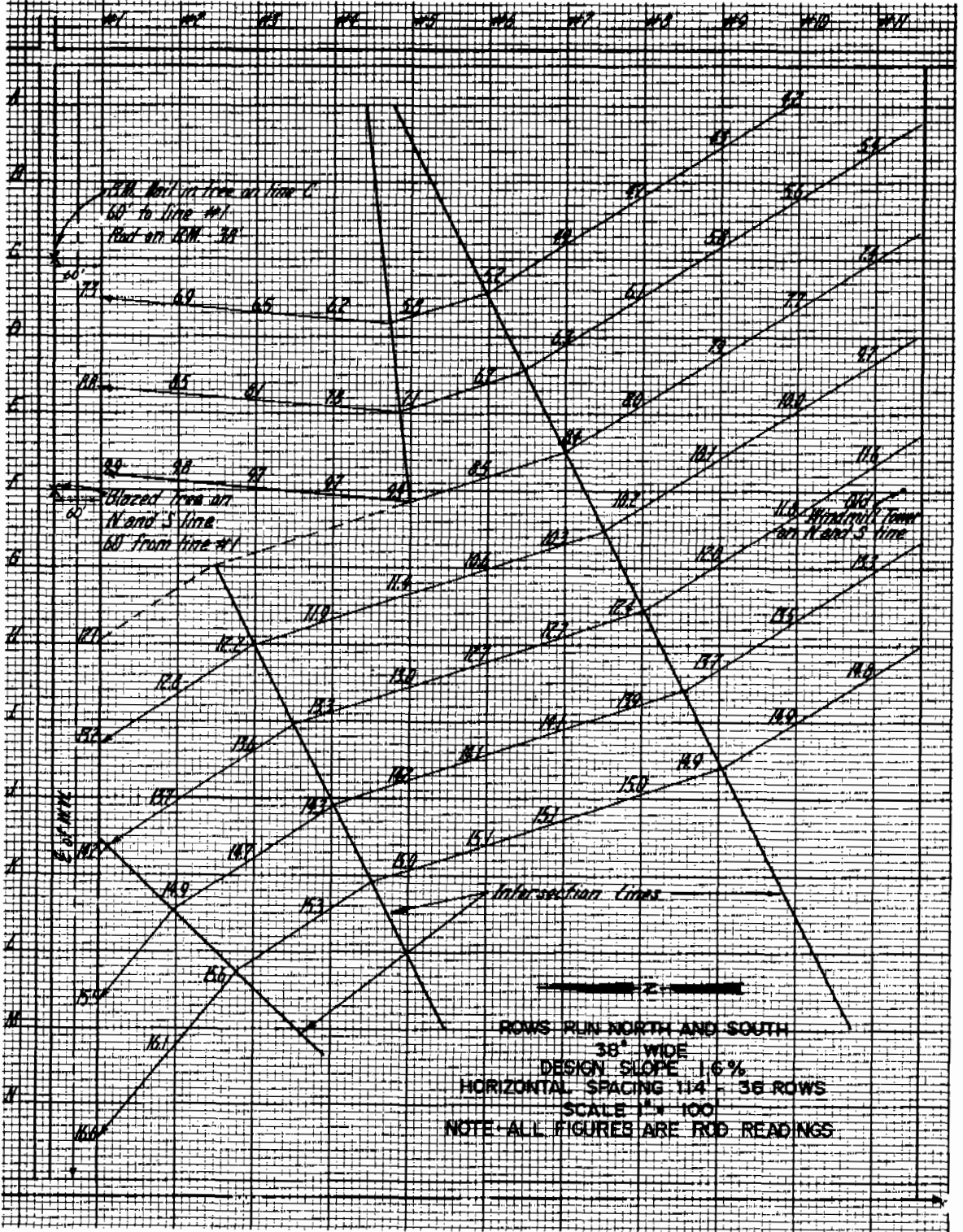
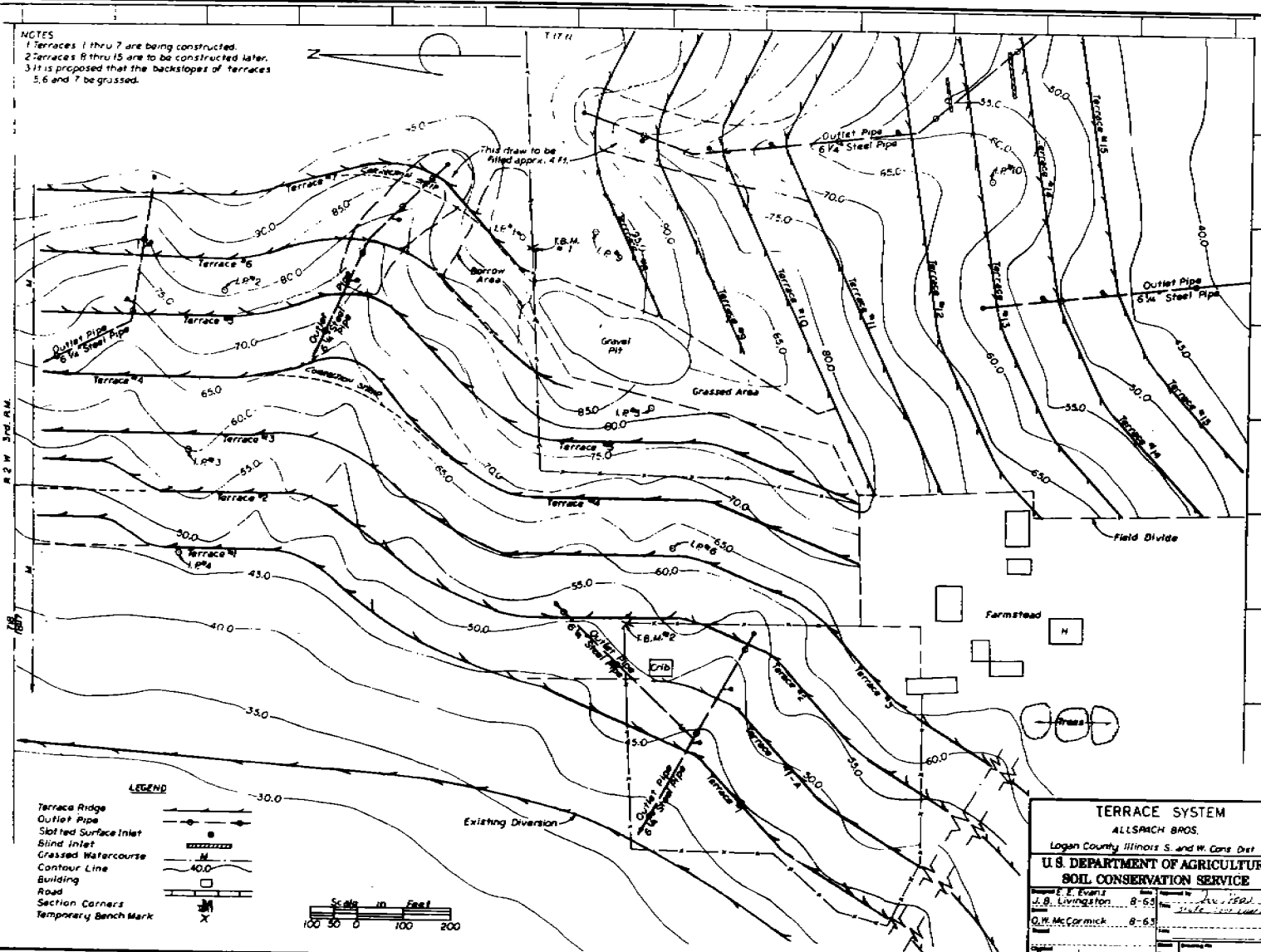

Figure 8-44 Graded parallel terrace system design developed from grid survey map in sheet 1. Terraces outlet into existing waterway on north side of field

**NOTES**

- 1 Terraces 1 thru 7 are being constructed.
- 2 Terraces 8 thru 15 are to be constructed later.
- 3 It is proposed that the backstops of terraces 5, 6 and 7 be grassed.



**LEGEND**

- Terrace Ridge
- Outlet Pipe
- Slot Inlet
- Blind Inlet
- Grassed Watercourse
- Contour Line
- Building
- Road
- Section Corners
- Temporary Bench Mark



**TERRACE SYSTEM**  
ALLSBAUGH BROS.  
Logan County Illinois S. and W. Cons. Dist.

**U.S. DEPARTMENT OF AGRICULTURE**  
**SOIL CONSERVATION SERVICE**

Prepared by J. B. Livingston Checked by O. W. McCormick	Date 8-63 Drawn by J. B. Livingston Date 8-63
--	--

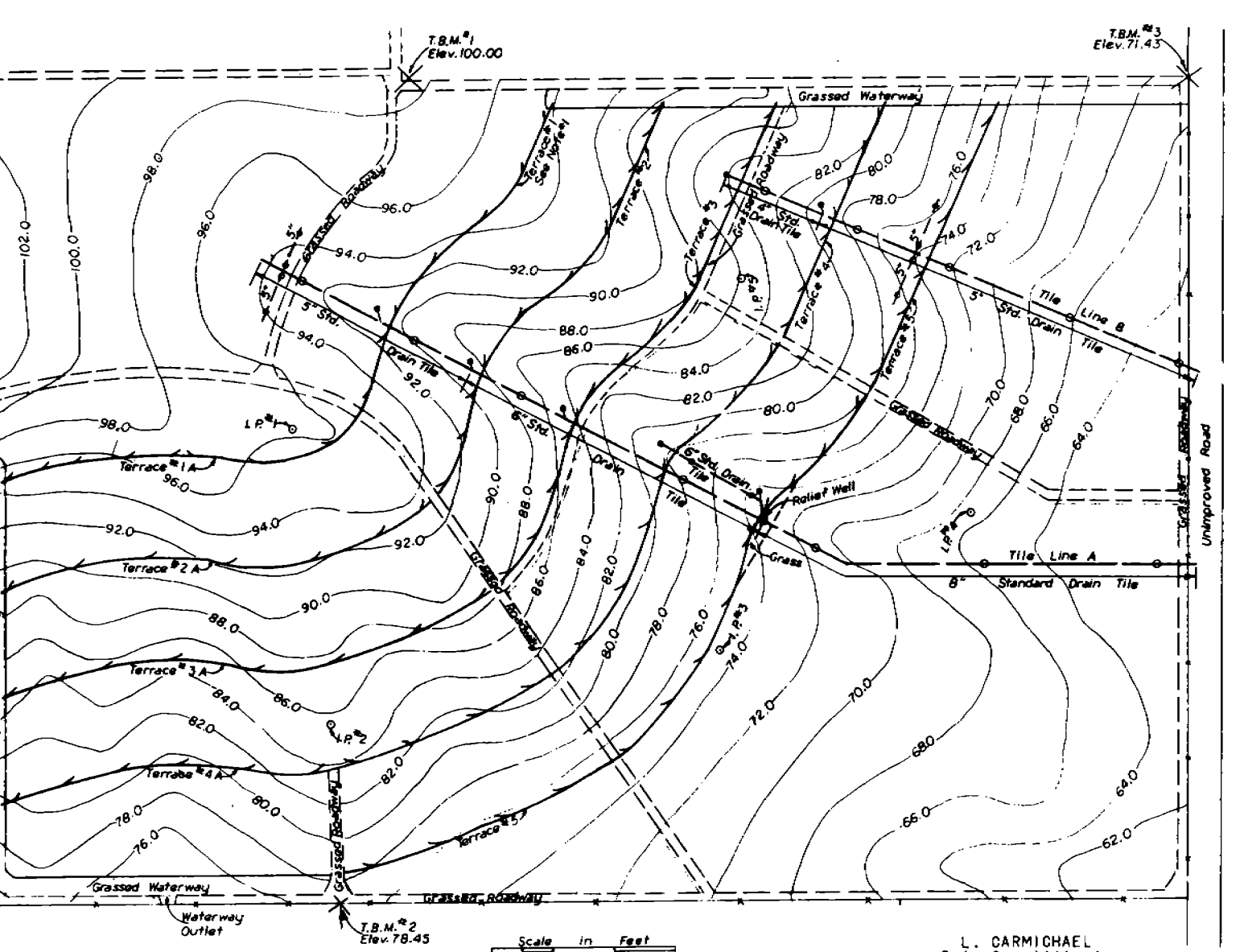

T.B.M. #1  
Elev. 100.00

T.B.M. #3  
Elev. 71.43

T.B.M. #2  
Elev. 78.45

Scale in Feet

L. CARMICHAEL

marking rows with plow points or chisels set at row spacing. This is continued through each pattern. The remaining terraces are then located by counting rows covering the terrace spacing. This eliminates point rows and odd areas which sometimes occur when a tape or chain is used for paralleling. It further gives the farmer an opportunity to drive out the system and recognize any sharp curves prior to construction. He also can see how to approach any odd areas.

### Layout Staking

The first question usually raised is, on what part of the terrace cross section should the stakes be set. There are at least three methods for staking terraces:

1. One of the most common methods is to set the stake at or near the centerline of the channel. This has a real advantage on broad base terraces where there are cuts and fills.

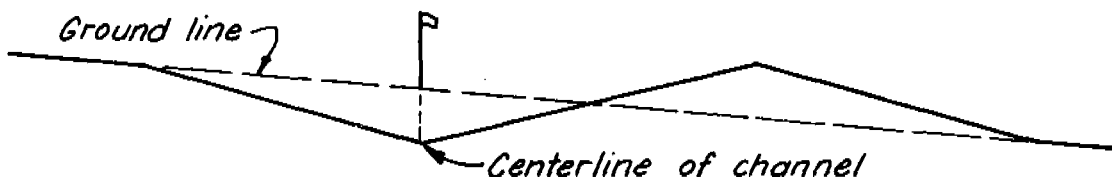

Figure 8-47 Method 1 - Staking

It is easy for the contractor to do the rough grading, simply making his cuts right alongside the stake. See Figure 8-48. He checks by measuring down alongside the stake. It has the disadvantage that the stake must be removed in order to obtain all the excavation.

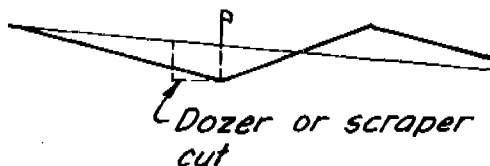

Figure 8-48 Showing first cut

2. A second method is to set the stake midway between the channel and the ridgetop. It has the advantage that on a terrace with little cut and fill, (or in other words, a terrace where the cross section is balanced) the stake sets on ground which has neither cut nor fill. This means the stake can remain undisturbed throughout most of the construction. Another advantage is that since the stake sets on the balance point, the stake will read 0.0 indicating neither cut nor fill for a balanced cross section. This makes it easier for contractors to interpret the job. See Figure 8-49.

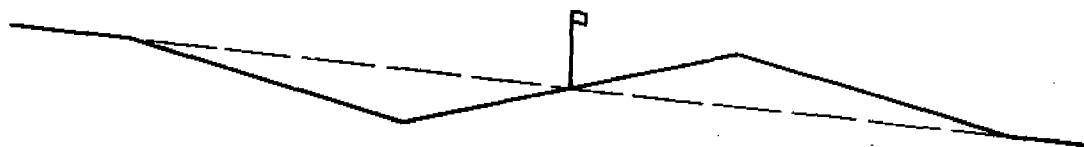

Figure 8-49 Method 2 - Staking

3. The third method is to set the stake on the ridge. Stakes are placed in this position rather infrequently, but it does have an advantage on level terraces, particularly broad base. Earth is moved into the stake line, thus making it easier to line up the terrace ridge. See Figure 8-50.

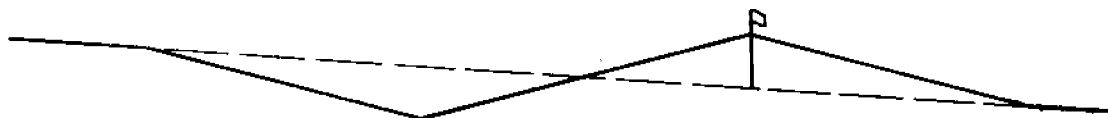

Figure 8-50 Method 3 - Staking

### THE KEY TERRACE

The key terrace is the terrace which is laid out first. It is usually placed in the middle of an anticipated group of parallel terraces. Therefore, it is representative of the entire layout and the average conditions. From it, the remaining terraces are staked parallel. The proper location of the key terrace will give the best parallel layout. If the first location does not give the required results, the key line must be relocated until the layout of this group meets the terrace objectives.

On long slopes, where a large number of terraces are required or on fields where there is a major slope change, it usually will be impossible to make all terraces parallel. The best layout will be to divide the terraces into groups. A key terrace is selected for each group. Each of the groups should contain two or more terraces which are parallel. By grouping the terraces it is possible to concentrate the uneven areas into one large correction area so that it will be more farmable. This may mean going back and shifting one of the groups to provide a more farmable correction area.

### Analyze the Field

Check on the variance in slope, the irregularities, and the total number of terraces needed. If four terraces or less are needed, try to use only one key terrace. Usually terrace number two will work the best. However, the top terrace may work better in some cases. If the hill is large and there will be four or more terraces, determine if two or more groups of terraces will be needed. Determine which of these terraces should be used as the key.

### Estimate the Center of the System

For example, if the terraces are to be about 1300 feet long, the center will be about 650 feet from each end. The location of this point is important because a gradient terrace with surface outlets should be staked both ways from the center. When a long graded terrace is staked by starting at one end, the other end may be higher or lower than is wanted. Starting at the center generally will save time in layout and in adjusting the terrace location.

Locate the Top of the Hill or Slope

This should be the point from which the top terrace is located.

Determine the Average Land Slope

Determine the average slope for the area to be terraced. If the slope varies from one terrace to another, determine the slope for each terrace.

Determine the Horizontal Interval

This should be determined for each terrace according to the average slope. Terraces usually have been staked using a vertical interval. However, in laying out parallel terraces, the horizontal interval should be used.

Locate Center of Each Terrace Above Key Terrace

Measure down from the top of the hill toward the center of the system (if this is possible), using the determined horizontal interval to locate the approximate center of each terrace. Set one temporary stake on each of the lines above the key terrace and one on the key terrace. This provides a good idea as to the approximate location of the key terrace and the terraces above it.

It is best to use two different colors of stakes in locating the key terrace. If the key line is staked with white flags, red flags could be used for the adjusted key. This gives a clear picture of the adjustments made. The remainder of the key terrace flags should be replaced with the same color as the adjusted portion. After the system is all staked the white flags should be removed.

Examine the Key and Then Adjust It

Move the stakes to eliminate some curves. Open the terrace at ridges if needed to eliminate a sharp curve. Eliminate reverse curves if at all possible, especially where they are close together or of sharp curvature. Where the line is almost straight for long reaches, or curves slightly back and forth from a straight line, try to restake as a straight line. On tile outlet terraces adjust from a level line by raising the line on ridges and lowering it at depressions to give the desired grade in the channel toward the tile outlet. See Figure 8-51.

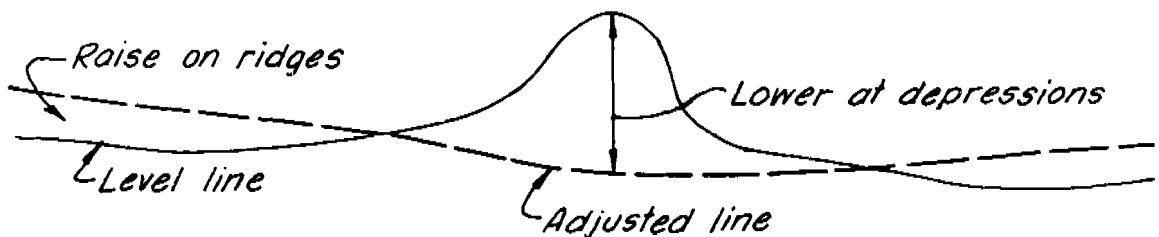

Figure 8-51 Adjustment of line crossing depressions

### Use the Step Offset Method for Staking the Curves

This simple method is used to measure the amount of curvature of the line. It gives the technician a way he alone can lay out uniform curves and check the distance from the curve to its center. Thus, he can estimate how far on the inside of the curve rows can be planted before they become too sharp.

If a curve as first staked does not lay out as desired, this method will help to determine how much to correct the curve for a second layout.

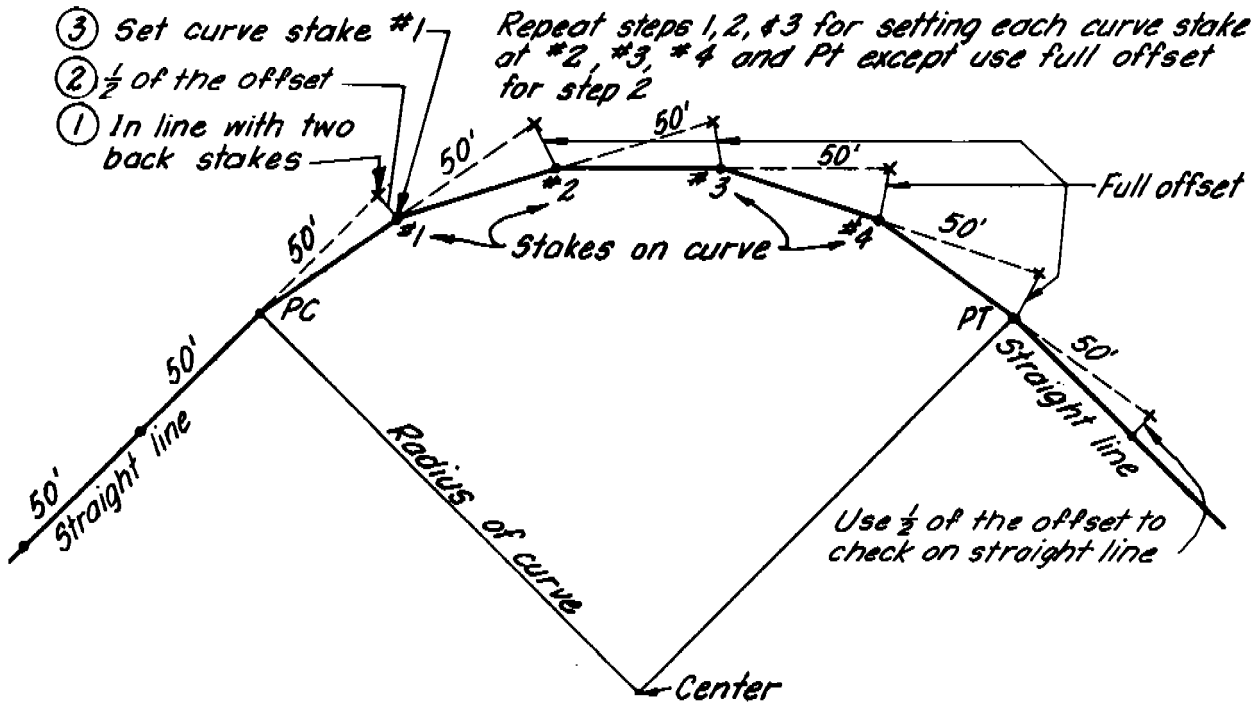

Figure 8-52 Step offset method for staking a curve

As shown in Figure 8-52, the technician first starts with a stake where a straight section ends and the curve begins (P.C.). He paces off the distance ahead to the next stake, usually 50 feet. He looks backward and lines in with the straight line. To offset the stake, he paces sideways one-half the selected offset distance and sets curve stake No. 1. He repeats this process for the remaining curve stakes and the P.T. stake, except that he now uses the full offset at each stake. Usually curves will run from one-to three-step offsets. If the selected offset is too large or too small to fit the curve to the P.T. another offset is selected and the curve restaked.

The formula for determining the distance to the center (radius) of a curve requires only the offset distance at each 50-foot station.

$$\text{Radius (in feet)} = \frac{2500}{\text{offset in feet}}$$

For example, if a three-step offset curve has been staked, the offset at each station is nine feet, using a 3-foot step. Then:

$$\text{Radius} = \frac{2500}{9} = 280 \text{ feet (approximately)}$$

If rows are planted on the inside of the curve, somewhere around 230 feet inside the staked curve they will become too sharp to farm. This assumes that equipment could work on a curve with a 50-foot radius.

It is best when staking the key terrace to limit the curve offset to five or six steps (15 to 18 feet). This should still permit another terrace to be located on the inside. For an individual terrace, it is best to limit the curve so that the offset is not greater than eight steps or 25 feet. This is a curve with a radius of about 100 feet.

### Recheck the Grade

The grade of the adjusted key terraces should be given a final check to make sure it is within allowable limits.

### Terraces Parallel to the Key

When the key terrace has been located, the terraces above and below it can then be staked parallel by plowing out the rows or measuring off the planned horizontal spacing from the key.

Probably the more accurate method of locating the other terraces is by marking off the rows parallel to the key terrace with tractor and plow points or chisels. This method was explained previously under Layout from Topographic Map.

If adjacent terraces are to be located by measurements, the measuring is always done at a right angle to the terrace from which the measurement is being made. Failure to do this is the biggest source of trouble in making lines parallel. Where sections of the key terrace are straight, measuring need only be done at the ends of the straight sections. Intermediate stakes can be sighted in. On curves, measure from the key line to the adjacent terrace at 50-foot intervals. Refer to the discussion on Curves and Straight Lines in the section on Layout Geometry for locating and determining the beginning and end of the curves.

The grade of each terrace must be checked after the terraces have been staked. If the grades are out of tolerance, determine if cut and fill along the lines will permit the lines to remain where they are. Generally, a reasonable amount of cut and fill will allow the terraces to remain. If not, the key terrace should be changed, or perhaps another terrace selected for the key.

Use all the techniques shown under Alignment to make the lines parallel. If these do not give the relief needed, correction areas will need to be planned. It may even be necessary to make further adjustment in terrace alignment in order to provide farmable correction areas.

## 11. DESIGN

The next step after the terrace system layout has been planned is to design the terraces and outlets. The design will depend on the type of outlet - surface or underground outlet - and the methods used for paralleling or providing the best possible alignment.

### TERRACE GRADE

In determining grades for terraces, due consideration should be given to such factors as soil type, spacing, and length of terrace. Grades should be sufficient to provide good drainage and develop adequate flow without scouring the channel and washing out crops. If the grades are not sufficient, a waterlogged condition may occur, crops may be drowned out, and farm operations made difficult.

A minimum grade of 0.1 to 0.2 is generally used. Level grades are not desirable on soils with low permeability but may be used for short distances. Reverse grades are not permissible.

In the upper 200 feet of a terrace the quantity of flow is small and steeper than normal grades may be used to improve alignment without causing erosive velocities. In this reach grades up to a maximum of 1.5 to 2.0 feet per 100 feet, depending upon terrace spacing and amount of runoff, are generally permissible. The maximum grade will be less as the terrace becomes longer and the peak rate of flow increases. The velocity should be checked against the permissible velocity for the soil for each change of grade.

### LENGTH OF TERRACE

Safe outlet capacity is an important factor in determining terrace lengths. In general, 1,800 to 2,000 feet is the maximum distance that a terrace should drain water in one direction. When the graded channel exceeds this length the terrace height becomes greater and this increases the earthmoving costs. When properly constructed and maintained, one-half mile long terraces will give satisfactory service on permeable soils, provided slopes are reasonably uniform. On badly gullied land a length of 1,200 feet should seldom be exceeded.

For tile outlet terraces it is a good practice to limit the length to about 1,200 feet per inlet.

### WATERWAY OUTLETS

Waterway outlets must convey runoff from the terrace or terrace system, at a safe velocity, to a point where it can be discharged without erosion damage. Terrace outlets should be installed before terrace construction, when needed to insure the establishment of a good vegetative cover in the outlet channel.

If the field to be terraced receives any appreciable amount of runoff from an adjacent area, plans must be considered to divert the runoff from the terrace system by some form of diversion or interception ditch.

Refer to Chapter 7, Grassed Waterways and Outlets, for the design of vegetated terrace outlets.

### CUT-AND-FILL METHOD

The major problem in the design of terraces which are to be built by the cut-and-fill method is to establish the gradeline of the channel and the ridge which will cause the earthwork to balance over the entire length of the terrace.

The following is a step-by-step procedure which can be used for design and layout. This procedure uses rod readings rather than elevations for stakes set in the terrace channel.

#### Survey the Terrace Line

After the terrace line has been established, take a rod reading at each stake, usually set every 50 feet. Enter these rod readings in the field notebook as shown in Figure 8-54. Convert all rod readings to the same HI if there is more than one instrument set up for a design segment.

#### Analyze the Rod Readings

Determine where the outlet will be on graded terraces. Determine the high points (lowest value of rod readings) where water will divide. These points are normally dividing points and terrace design and earthwork balance usually will be calculated between these divides.

#### Determine the Average Rod Reading

For the section being designed, add the rod readings and divide by the total number of readings. If stakes are set every 50 feet, each intermediate stake represents 50 feet of line. However, end stakes may only represent 25 feet. If this is true, add one-half of the sum of the two end readings to the sum of the intervening readings and divide the total by the number of rod readings minus one. This equals 9.5 for the example in Figure 8-54.

The average rod reading means that if the land lengthwise of the stake line was all graded level, the rod reading all along the line would be the average rod reading.

#### Locate the Balance or Midpoint

This will be the center of the design length. If the design length is 600 feet, the balance point will be at the 300-foot point. Note in Figure 8-53 that the center point does not change elevation as the line is tipped. The average rod reading will be at the center point, hence if the line is tipped either way the average rod reading does not change. Now if

a plane is passed through this balance point at an elevation equal to the average rod reading the volume of excavation will equal the volume of fill regardless of how the plane is tipped.

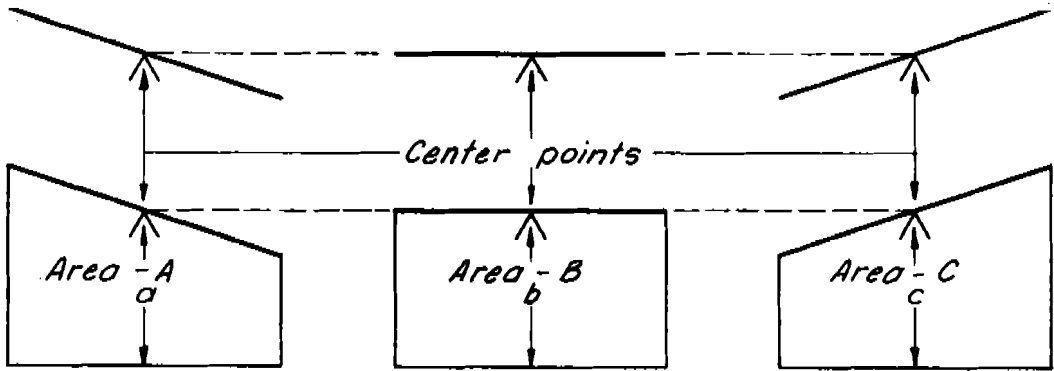

$$a = b = c \quad \text{Area A} = \text{Area B} = \text{Area C}$$

Figure 8-53 Theory of the balance point

The above figures were drawn of equal height below the balance point or center. They all contain the same area and represent the theory behind the balance point.

Sta.	Terrace #3				Graded Terrace - Cut & Fill	
	Rod	Grade Rod 1 1/2" HI Channel	Cut or Fill			
0+00	13.4	12.1	F 1.3		Field Slope	4 %
+50	11.4	11.8	C 0.4		Terrace Grade	0.6 %
1+00	9.3	11.5	C 2.2		Terrace Length	600'
+50	10.9	11.2	C 0.3		Finished Height	0.8'
2+00	12.2	10.9	F 1.3		Front Slope	15'
+50	9.0	10.6	C 1.6		Spacing	120'
3+00	8.3	10.3	C 2.0	Balance Point	Cut for a	
+50	9.3	10.0	C 0.7		Balance Section	0.8'
4+00	10.1	9.7	F 0.4			
+50	8.5	9.4	C 0.9			
5+00	7.0	9.1	C 2.1			
+50	7.0	8.8	C 1.8			
6+00	8.0	8.5	C 0.5			
Total						
0+50 to 5+50	103.0					
Avg. Rod	$= \frac{103.0 + \frac{(13.4 + 8.0)}{2}}{13 - 1} = \frac{113.7}{12} = 9.5$					
					Grade rod @	
					balance point = 9.5 + 0.8 = 10.3	

Figure 8-54 Graded terrace cut-and-fill notes

### Determine Grade Rod of the Channel at the Balance Point

First, determine the amount of cut which will be necessary in the channel in order to build the terrace on the particular slope in question with a balanced cross section. The cut can be determined for any ground slope and width of front slope. See Figures 8-14 and 8-15. For certain depths the amount of cut, "c", in the channel can be read from Exhibit 8-1.

In the example shown in Figure 8-54 a terrace with a broad base cross section on a 4-percent slope is to be designed 0.8 foot high (design height). The "c" value (or cut in channel to build this) will be found in Exhibit 8-1 to be 0.8 foot.

After the amount of cut necessary for the specified terrace height has been determined it is added to the average rod reading. This gives the grade rod of the completed channel at the balance point or center. In our example, the average rod reading is 9.5. To this, a cut of 0.8 is added giving a grade rod reading at the balance point of 10.3.

### Establish the Channel Grade

Proceed from the center point both ways with a planned grade. In the example, Figure 8-54, the channel grade rod is 10.3. The terrace grade is 0.6 percent or 0.3 foot for each 50-foot station. To find the grade at each station start at the balance point (10.3) and reduce the reading by 0.3 for each 50-foot station going uphill and increase by 0.3 going toward the outlet.

If the planned grade does not seem to fit well or will not properly discharge the terrace into the outlet, change the grade and try again. On level terraces, the grade is zero so calculations are much simpler.

A uniform grade from one end of the terrace to the other is not a requirement and is seldom possible with parallel terraces. A terrace line may be broken into segments with different grades. However, each segment must have a uniform grade and be handled as a separate cut-and-fill problem. It may require plotting of the entire terrace profile to establish the correct grade and the points at which grades should be changed.

### Determine Cuts and Fills

A cut is required where the grade rod exceeds the original ground rod. A fill is required where the grade rod is less than the original ground rod. Referring to the example, Figure 8-54, the ground rod at Sta. 3+00 is 8.3 and the grade rod is 10.3 requiring a cut of 2.0 feet. At Sta. 4+00 the ground rod is 10.1 and the grade rod is 9.7, requiring a fill of 0.4 foot.

A study should be made to determine the distribution of cuts and fills. This can be done directly from the fieldbook notes or by plotting the profile. On graded terraces, it may be desirable to adjust the grade, within safe velocity limits, to prevent excessive earth haul from one end of the field to the other. Grades can be increased or decreased as dictated by the overall fall from one end of the terrace to the other.

The earth to complete the terrace may run long or short. Shortage of earth to make the fills is more desirable since it can be remedied by merely lowering the gradeline of the terrace channel by one or two tenths. This could be done during construction by the technician or contractor as the shortage becomes apparent.

### GRADED TERRACES USING UNDERGROUND OUTLETS

The graded terrace using underground outlets incorporates the principle of retarded flow. It is designed so that the storm runoff is temporarily stored and carried away gradually through the underground outlet. The storage is developed by building the terrace straight across waterways or depressions, with the ridgetop built level and the channel bottom graded to the outlet.

#### Storage Requirements

Sufficient storage should be provided to protect the terrace from overtopping. The amount of storage required is generally based on a 10 year frequency storm. A minimum capacity of 2.0 inches of runoff is often used.

#### Drainage Coefficient

The outlet conduit is designed to remove the water stored in each terrace in a specified period of time. The maximum time recommended is 48 hours. Shorter dewatering periods will reduce the possibility of crop loss due to flooding and provide more protection against storms that may occur on successive days.

For example, if the 10-year frequency runoff under average conditions is 1.9 inches, design the storage in the terrace for 2.0 inches. To remove the runoff in two days, the minimum release rate, or drainage coefficient, would be one watershed inch per day. If removed in one day, the drainage coefficient would be two inches per day. Drain tile used for the outlet conduit should not be smaller than 4 inches. Since drainage areas are small and tile grades are moderate to steep, the drainage coefficient is usually much greater than the required minimum.

#### Terrace Storage Capacity

The terrace must be high enough to provide the required storage capacity. It will be necessary to compute the available terrace storage with a given height. Storage is not as easy to compute on gradient terraces as it is on a level terrace, as the depth of water varies widely along the graded terrace. The simplest method is to determine the average storage per linear foot of the terrace. Storage will be of two kinds, natural storage and excavated storage.

Natural storage is that storage above a terrace which occurs on top of the natural ground and against the terrace. It would be the entire storage on a terrace if there were no uphill borrow.

Excavated storage is that created by uphill borrow. Many terraces have both natural and excavated storage as shown in Figure 8-55.

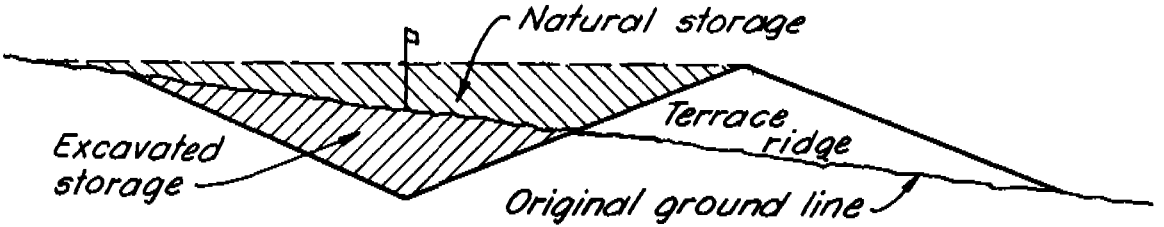

Figure 8-55 Storage - Natural and excavated

The following outlines procedures for determining the terrace height necessary to provide the required storage.

Natural Storage Design Procedure

In this example, the terrace will have a grass back slope cross section with the excavation all from the downhill side. Thus, all the storage will be natural storage. Refer to Figure 8-56 for field notes and calculations for the example.

(1)	(2)	(3)	(4)	(5)	(6)	(7)
		Water Rod	Storage	Grade Rod		Graded Terrace with Underground Outlet
		1st H.I. (Ridge)	cu. ft. Channel	Channel		
0+00		Stake Pulled				Channel Cut
+50		6.2	-			Land Slope 12%
1+00		6.4	-			Terrace Spacing 110'
+50		6.5	-			Storage Required 2.0"
2+00		7.0	-			Terrace front slope 14'
+50		8.3	0.7	7		V-Channel
3+00		8.9	1.3	16	8.9	
+50		9.1	1.5	20	9.0	Avg. Rod at Intake = 10.1
4+00		9.8	2.2	36	9.1	Try h = 2.5
+50	2nd H.I.	9.0	1.4	18	9.2	Ridge = 10.1 - 2.5 = 7.6
5+00	7.1 (+14)	8.5	0.9	10	9.3	Trial #1 Try Ridge = 7.6
+50	8.0	9.4	1.8	26	9.4	
6+00	8.8	10.2	2.6	46	9.5	Req'd. Storage = $\frac{110}{6} = 18.2 \text{ cu. ft. / ft.}$
+50	8.2	9.6	2.0	31	9.6	
7+00	8.3	9.7	2.1	33		No. of Segments = $\frac{900}{50} = 18$
+50	8.6	10.0	2.4	41		
8+00	8.8	10.2	2.6	46	(Intake)	Available Storage = $\frac{330}{18} = 18.3 \text{ cu. ft. / ft.}$
+50	6.2	7.6	-			Trial O.K.
9+00	4.9	6.3	-			
+50	4.8	6.2	-			
				330		

Figure 8-56 Notes - Graded terrace with underground outlet

1. Enter the rod readings for each 50-foot stake set in the channel along the terrace.
2. Convert all rod readings to the same HI if there is more than one instrument setup. However, this needs to be done only for a particular design section. Note that the instrument was moved, with Sta. 5+00 used for a turn. The foresight on 5+00 was 8.5 and the backsight was 7.1. Enter readings from first HI in the third column, those from the second HI in the second column. In the example, readings from the second HI were converted and placed in the third column by adding 1.4 to each.
3. Plot and analyze the rod readings. Determine where the underground outlet will be. In the example, the outlet should be at Sta. 8+00 which is the low point. See Figure 8-57 for plotted profile. Determine the high points where water will divide to establish the design length. In the example, this is from Sta. 0+50 to 9+50 = 900 feet.

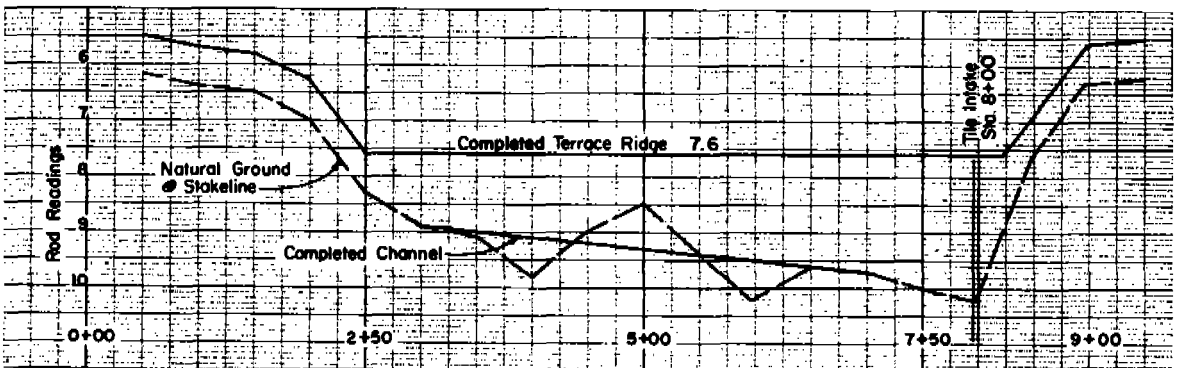

Figure 8-57 Profile of terrace (Borrow was obtained from ridges to complete the fill section)

4. Establish a proposed top or ridge height for the storage section of the terrace. Plot this estimated elevation or grade rod on the terrace profile as shown in Figure 8-56.

The readings at the ends of the terrace that are much higher than the assumed level ridge top should be eliminated from the storage calculations. In this example, the first four readings and the last three readings were not used since these parts of the terrace will be built only as a graded terrace.

Locating the required ridge height is a cut-and-try process. Experience in the design of this type of terrace provides the best judgment in locating the ridge height. The following guides are based on past designs and may be used as a starting point.

<u>Percent of the length of terrace over which water will be stored</u>	<u>Estimated maximum design height measured at the average low point at the intake</u>
Approx. 75 percent of length	2.0 feet
Approx. 50 percent of length	3.0 feet
Approx. 25 percent of length	4.0 feet

These guides work best on slopes of 3 to 6 percent and for a design length of terrace of 1,000 feet or less. For terraces over 1,000 feet, add additional height as the design section becomes longer.

In the example 10.1 was considered average rod near the intake. The storage portion is + 60 percent of terrace length so 2.5 was used for the maximum design height. Grade rod at ridge = 10.1 - 2.5 = 7.6.

- Determine the water depths at each station and record in Column 4, Figure 8-56. For example, at Sta. 4+00 the ground rod is 9.8, the proposed ridgetop is 7.6, and the water depth will be  $9.8 - 7.6 = 2.2$  feet.

In this example the water depth is computed from the original ground shots. By doing this it is assumed that cut and fill in the channel with a continuous grade to the inlet will balance and will not change the amount of storage. When it appears that cut and fill in the channel will not balance then the water depth should be computed to the planned grade and Exhibit 8-3 will have to be used because there is both natural and excavated storage.

- Determine the storage at each station. Record these figures in Column 5. This storage is expressed in cubic feet of water per lineal foot. The amount of natural storage for any given depth and land slope can be found in Exhibit 8-2. Example: At Sta. 4+00 for a depth of 2.2 feet and a 12-percent slope the storage amounts to 36 cu.ft./ft.

Exhibit 8-2 is to be used where all, or the majority, of the excavation comes from other than in the terrace channel. This would be the case where terraces have grass back slopes and the excavation comes from the downhill side. It would also pertain to broad base terraces where fill for the terrace is carried in with a scraper from a distant source. All calculations are based on a stake line 14 feet uphill from the completed terrace ridge. Where fills are over 3 feet, front slope should be increased to 28 feet to give better farmability.

- Determine the available storage. Add the storage volumes in Column 5 and divide by the number of 50-foot increments. This gives the average storage along the length of the terrace. Total storage from Col. 5 = 330 in the example. The number of increments are 900 feet of terrace  $\div$  50-foot stations = 18. The

average available storage prorated over the entire length of the terrace is then  $\frac{330}{18} = 18.3$  cu.ft./ft.

8. Determine the required storage. Multiply the average width of the drainage area above the terrace by the storage required in feet. In the example, the average width of the drainage area above the terrace (terrace spacing) is 110 feet and 2 inches (1/6 of a foot) of storage are required, then 110 ft. x 1/6 ft. = 18.2 cu.ft./ft. This is slightly less than the storage available, therefore the height estimated in step 5 is satisfactory.
9. Recompute if necessary. If the storage is too low or too high, recompute the terrace with a different height.

#### Excavated Storage Design Procedure

Where all or part of the fill for the terrace comes from uphill borrow, storage will be increased due to the excavation. This increase in storage can be used to reduce the ridge height.

Storage calculations are based on the average storage in cubic feet per foot of terrace length required to store the runoff from a one-foot width of the terrace interval. This method assumes that the storage volume is spread over the entire length of the terrace. Therefore, all survey stations must be at the same interval.

A procedure for determining storage volume when all or part of the channel is excavated is shown below. An example of the necessary field notes and calculations are given in Figure 8-58. In the example, the terrace has a broad base cross section, a "V" channel, a field slope of 5 percent and a terrace spacing of 140 feet.

1. Enter the rod readings for each station along the stake line. This step is the same as for natural storage design. See Figure 8-58.
2. Plot a profile of the rod readings. Study the profile and locate the high points where water will divide. This determines the design length. Then locate the inlet. With the inlet elevation as the control, set the grade for the terrace channel and draw this on the profile as shown in Figure 8-59.
3. Establish a proposed top or ridge height for the storage section of the terrace. Plot this estimated elevation or grade rod on the terrace profile as shown in Figure 8-59.

The guides for estimating the ridge height were explained in item 4 under Natural Storage Design Procedure. In the example, 10.3 was considered the average rod near the intake (Average for 100 feet each side of intake). The terrace is more than 1,000 feet long, and the storage section is more than 75 percent of the terrace length. Try a maximum height of 2.1. The grade rod at the ridge would be  $10.3 - 2.1 = 8.2$ .

4. Determine the water depth at each station. This is the difference between the grade rod of the ridge and the proposed bottom of the terrace. In the example, at Sta. 5+00 the terrace bottom grade rod is 10.2. Subtract ridge grade rod of 8.2 giving the water depth of 2.0. Do this for each station and enter in Column 4, Figure 8-58.
5. Determine the cut depth at each station. This is the difference between the rod readings at the stake line and the proposed bottom of the terrace channel. At Sta. 5+00 with the bottom grade rod of 10.2 and the grade rod at the ground line of 10.1, a cut of 0.1 will be required. Do this for each station and enter in Column 5.
6. Determine the end area at each station. For the design depth shown in Column 4 and the cut depth shown in Column 5, select the end area from Exhibit 8-3. At Sta. 3+00,  $d = 1.4$ ,  $C = 0.8$ . From Exhibit 8-3, sheet 5, for 5-percent field slope, the end area = 16 square feet. Enter this in Column 6.

①	②	③	④	⑤	⑥	
Sta.	Rod Read.	Channel Grade Rod	Water Depth	Cut Depth	Storage	
0+00	7.9					
1+00	8.3	9.0	0.8	0.7	8	
2+00	8.6	9.3	1.1	0.7	11	
3+00	8.8	9.6	1.4	0.8	16	
4+00	9.7	9.9	1.7	0.2	35	
5+00	10.1	10.2	2.0	0.1	50	
6+00	10.6	10.5	2.3	0.0	69	
7+00	10.0	10.2	2.0	0.2	47	
8+00	9.2	9.9	1.7	0.7	24	
9+00	8.9	9.6	1.4	0.7	17	
10+00	8.1	9.0	0.8	0.9	8	
11+00	7.8	8.4	0.2	0.6	2	
12+00	6.9	7.8				
				Total	287	
Total (Actual) =					Total	
					No. of Segments	
= $\frac{287}{12}$					= 23.9 cu. ft.	
∴ Trial - OK						

10/10/66	
J. Smith, Ogle Co. B. Jones, T. & W.	
Terrace #1	M. Robb &
Broad Based	
V-Channel	Field Slope 5%
	Terrace Spacing
	140'
	Required Storage
	$2' \text{ or } \frac{2 \times 140}{12} =$
	23.3 cu. ft.
Intake	
	Rod near
	Intake = 10.3
	Try -
	Max. height
	of 2.1
	Then -
	Ridge =
	$10.3 - 2.1 = 8.2$

Figure 8-58 Notes - Graded terrace with underground outlet - broad base cross section

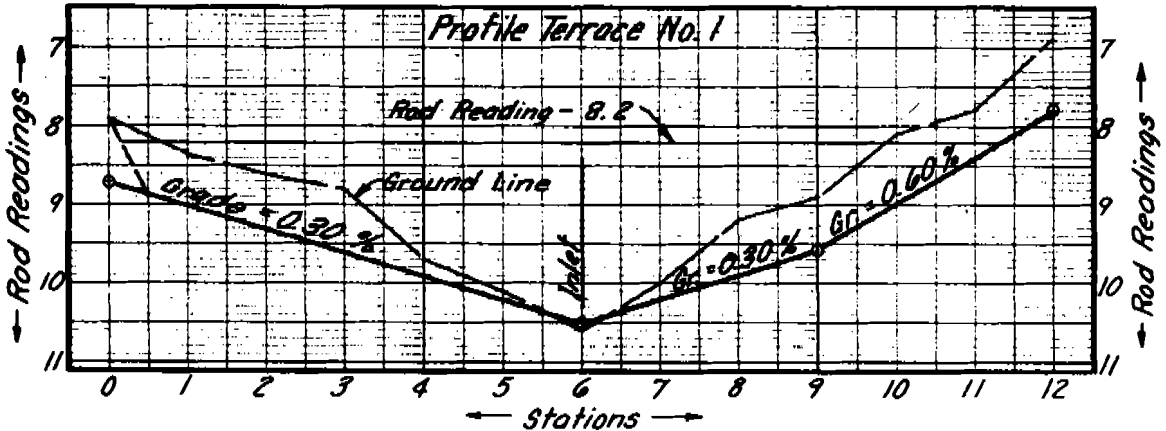

Figure 8-59 Profile for terrace design example

Exhibit 8-3 has been developed to aid in computing combined natural and excavated storage. The exhibit can be used where the storage is all natural ( $c = 0.0$ ); where the storage is a combination of natural and excavated; and where the storage is all excavated. See Figure 8-60. In using this exhibit, first determine the land slope at each station and refer to the exhibit for that land slope. The storage figures in the exhibit are cubic feet per lineal foot of terrace (end area in square feet times a unit length of one foot). The exhibit has been carried only to a "d" of 3 feet. It will be rare if there is excavation in the channel of depths over this amount. For natural storage on depths over 3 feet use Exhibit 8-2, Natural storage above terraces.

This exhibit is based on a "V" channel cross section with a 14-foot front slope and an excavated cut slope of 6:1. The stake line in the "V" channel is 14 feet uphill from the completed terrace ridge. The terrace ridge is constructed to the design depth "d", even when "c" exceeds "d" (see drawing 4 in Figure 8-60). This means that the water surface at depth "d" always measures 14 feet from the stake line to the completed terrace ridge. Free-board will have to be provided above the "d" level.

7. Determine the available storage. Total all of the end areas in Column 6. Divide this total by the number of survey stations in the design length of terrace to determine the storage in cubic feet per foot of length. The full length of the terrace must be used as the average end area must be applied to the full length, not just the storage portion of the profile. This is because the full length must be used in step 8 to determine the required storage based on the total runoff to the entire design length of terrace. In the example the available storage provided per foot of length is  $\frac{287}{12} = 23.9$ .

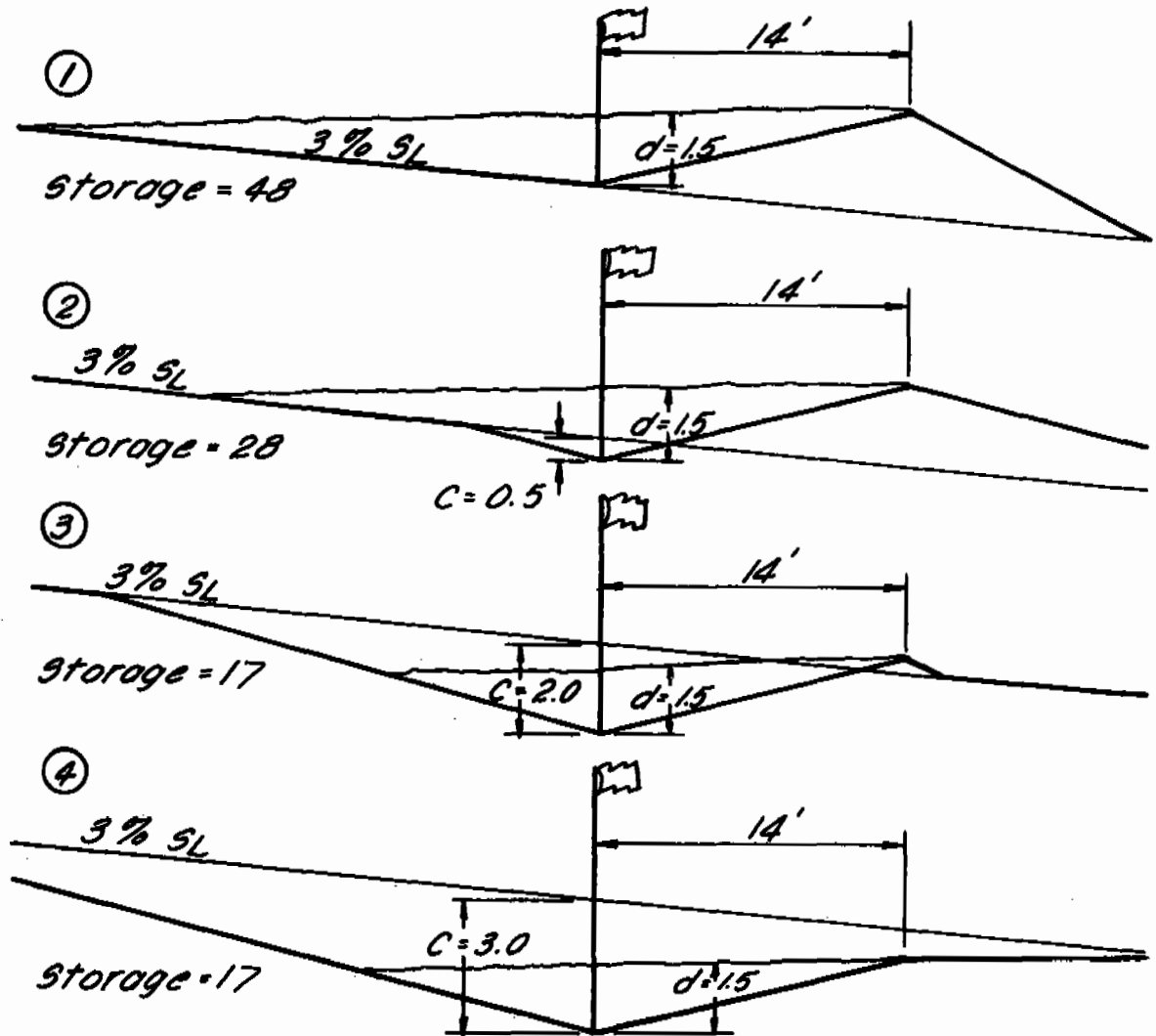

Figure 8-60 Examples of "c" and "d" situations for figuring storage

8. Determine the required storage. Multiply the average width of the drainage area above the terrace by the depth of the runoff in feet. The required storage in this example is equal to  $140 \times \frac{2}{12} = 23.3$  cubic feet per foot. As the available storage in the previous step is 23.9, the first trial meets requirements and the grade rod for the designed height of the terrace is 8.2. Additional height should be added to the terrace to allow for freeboard and settlement.

If the available storage is less than the required storage, raise the terrace ridge and recompute the available storage. If the available storage in step 8 is significantly more than the required storage, lower the grade rod of the terrace and recompute the available storage. Seldom will more than two trials be required to determine the ridge height of a terrace of this type.

If a flat-bottom terrace channel is used instead of a "V" channel, Exhibit 8-3 cannot be used to calculate the storage. In this case, computations for the excavated storage should be made at each station and added to the natural storage to obtain the total storage at each station.

### Design of the Outlet Conduit

The tile outlet is designed to remove the calculated volume of terrace storage in a specified time interval.

The outlet conduit can be designed by either of two methods using Exhibit 8-4, Tile design chart for underground outlets. One method is by using required discharge in cubic feet per second for the selected drainage coefficient and the other method is by using acres drained and the selected coefficient. Exhibit 8-4 provides a selection of drainage coefficients from 1/2 inch to 3 inches for both discharge in cubic feet per second and acres drained. Using drainage area in acres is the simplest and most common method.

The tile should be designed for open channel flow with velocities in accordance with National Engineering Handbook, Section 16, Chapter 5. The design procedure is to start with the top terrace and accumulate the drainage area or discharge rate of each terrace, moving downhill.

The following example illustrates this procedure using drainage areas:

Given - Slope of tile outlet through all terraces = 3.0 percent  
 Slope of tile outlet across bottom = 0.5 percent  
 Drainage coefficient = 2.0 in./day

Using the Design Chart determine the tile sizes required:

Terrace Number	Incremental Drainage Area-Acres	Accumulated Drainage Area-Acres	Drainage Coefficient Inches	Slope of Tile Line Percent	Size of Tile Required from Exhibit 8-4 Inches
1	4.0	4.0	2	3	4
2	2.0	6.0	2	3	5
3	3.0	9.0	2	3	6
4	2.0	11.0	2	3	6
5	3.0	14.0	2	3	8
Main Outlet		14.0	2	0.5	10

### Intake or Riser

The intake extends above the ground and directs the flow into the underground outlet. Intakes generally are placed on a lateral leading to the main line. The lateral should be of sealed conduit. The intake should be of sturdy construction and securely connected to the lateral conduit. The intake should extend almost up to the elevation of the terrace top. This gives a higher factor of safety against plugging by trash.

It also permits sediment to build up gradually over the years without having to raise the intake. For this reason the beehive grating is not recommended.

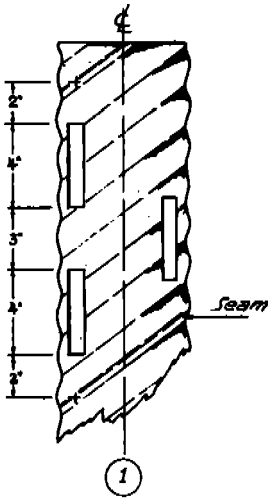

SLOTTED INTAKE

1. Cut 1"x4" slots in 4 rows around the pipe (90° spacing). Do not space closer than 2" to the seams or end of pipe.
2. Capacity - 20 acre inches per day.

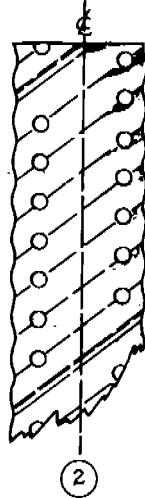

ROUND HOLE INTAKE

1. Fabricate 24 holes per lin. foot; 3/4" diameter.
2. Alternate fabrication - approximately 12 holes per foot of 1" diameter.
3. Capacity - 8 acre inches per day.

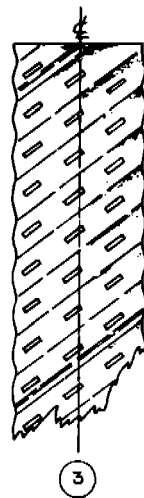

CHISEL PERFORATED

1. Fabricate 12 rows of 3/16" x 1" slots, (30° spacing).
2. Capacity - 10 acre inches per day.

GENERAL NOTES

1. Alternates - three are shown. All holes shall be carried to ground line or below.
2. Fabrication - all intakes are fabricated from 16 ga. 6" dia. H.C.M.P. Any job needing more capacity will require a special design.
3. Wrapping - openings which extend below ground shall be wrapped with a fiber glass material.
4. Restricted flow - flow may be restricted, when necessary, by two methods:
  - a. Size the sealed conduit. Minimum size is 4".
  - b. Use an orifice plate, placed in the tee as shown.
5. Trash Guard - shall be provided at the top of each intake. One type can be made by drilling holes and inserting two horizontal bars at a 2" spacing.

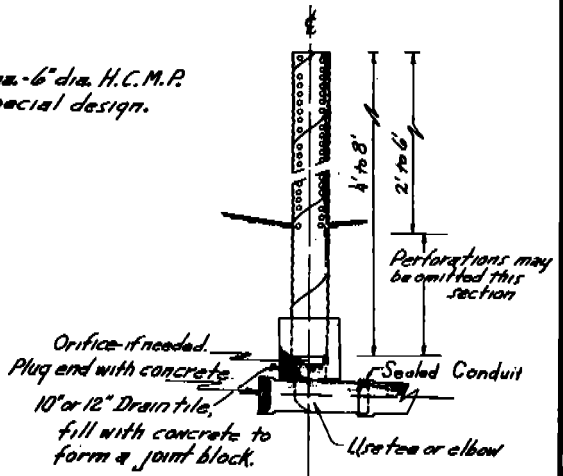
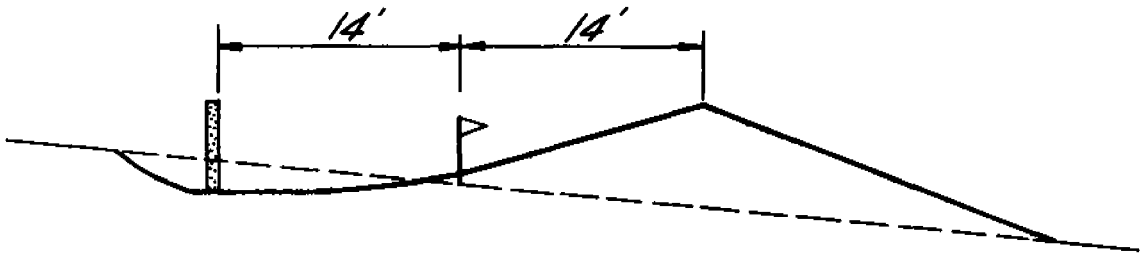

Figure 8-61 Types of opening for intakes of helical corrugated metal pipe

Helical corrugated metal pipe is generally used for the intake. Openings should be placed in it from the ground level to the top to permit flow to enter and still restrict floating grass, stalks, and other trash. Openings have been made of slots (1 x 3 inches), round holes (1/2 to 1 inch in diameter), and chisel perforations (usually 3/16 to 1 inch). The openings should be sufficiently numerous to pass the required flow even if some are obstructed. See Figure 8-61 for information on the three types of openings for intakes. Other types of intakes can be used that fulfill the above criteria.

The intake generally is placed at the lowest spot on the terrace profile in order to drain all the terrace channel. It should be placed uphill of the terrace ridge - a multiple of the planting and harvesting equipment widths - so that it will pass all equipment which will be used.

It may be necessary to either excavate around the intake, or fill in the channel, so that the intake is the lowest part of the completed terrace channel. See Figure 8-62. If the fill is rather high at the intake, the front slope will need to be lengthened to prevent it from becoming too steep.



*On most fills (under 3') grade around the intake so the terrace channel will all drain to the intake.*

Figure 8-62 Grading around intake

This also requires placing the intake farther away. As an alternate, the channel can be filled to lessen the height. This will permit placing the inlet closer to the ridge. See Figure 8-63.

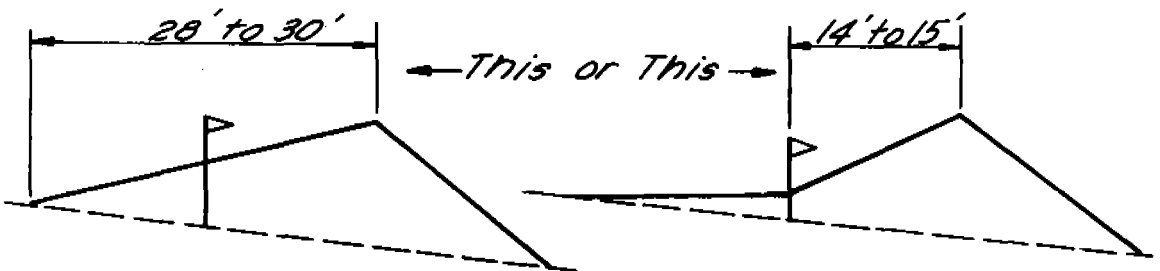

*Use a 28' to 30' front slope on fills over 3 feet*      *Fill in channel to lessen the height to 3 feet and use a 14' to 15' front slope*

Figure 8-63 Front slope treatment for fills over 3 feet

To protect the intake from damage by equipment or livestock, it is best to leave a small area in sod around the intake. Crops should be planted out around the grassed area so that equipment will be led away from the intake. See Figure 8-81. A series of fence posts placed around the intake also will protect against livestock and equipment damage.

#### Preventing Pressure Flow in Outlet

If a large number of terraces are graded to an underground outlet, overtopping of the lower terraces may occur if the same conduit size is used throughout and the lower end of the conduit is on a much flatter grade than the upper end. Pressure flow may develop in the line and cause water to flow out of the lower intakes rather than into them. This might cause the lower terraces to overtop. There are several methods which can be used in design to prevent this.

#### Conduit Sizing

The main outlet conduit can be sized using approximately the same drainage coefficient for all terraces with the size of the line increasing as it proceeds downhill. This approach is not always practical as this may call for the upper part of the main to be 2½ inches in diameter, or some other odd size, and 4 inches at the lower end. However, the conduit should be sized according to this principle as far as practical. For example, if tile is used, 4-inch tile might be used at the upper end, 5 inches in the middle portion and 6 inches for the outlet end.

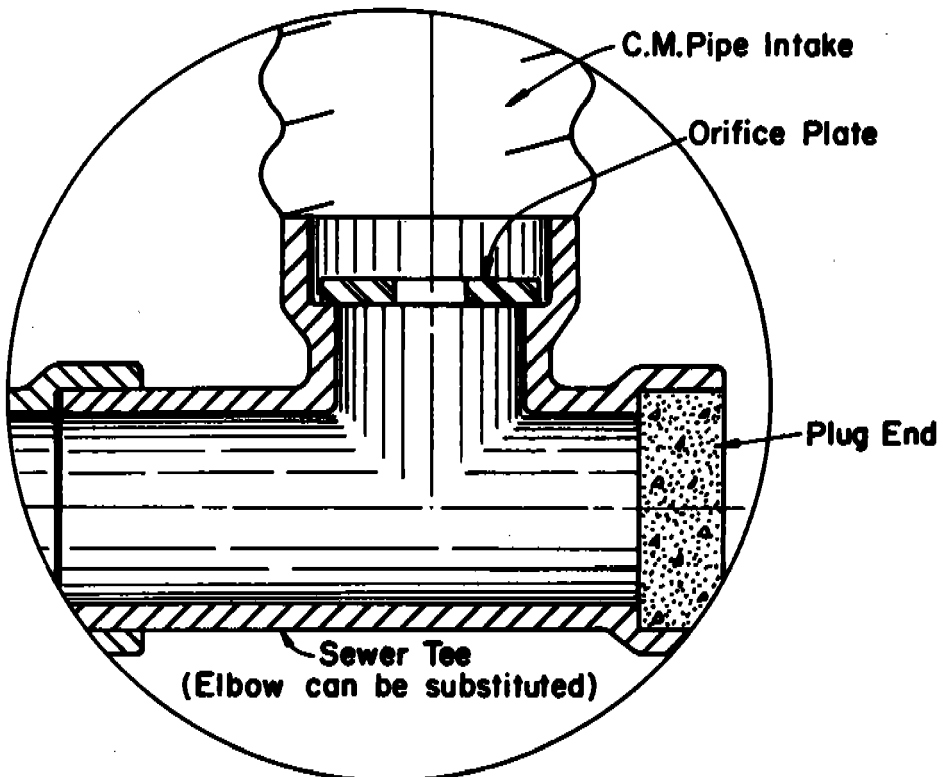

Figure 8-64 Closeup of intake showing orifice plate location

### Restricting Device in the Intake

The flow may be restricted before it enters the main. This should not be done by reducing the size or number of holes in that portion of the intake above ground. The restriction should be placed in the intake below the ground level. One of the simplest devices is a flat metal orifice plate lowered into the intake from above and set on the shoulder of the bell of the sewer tile. Should it become plugged, it can be removed by using a rod with a hook on one end. See Figure 8-64.

When an orifice plate or some other type of restriction is used it will be necessary to determine the discharge in cubic feet per second for the drainage coefficient used, the drainage area of the inlet (Exhibit 8-4), and the head of the orifice. See Figure 8-65. With this information, the diameter of orifice and size of riser pipe can be determined from Exhibit 8-5.

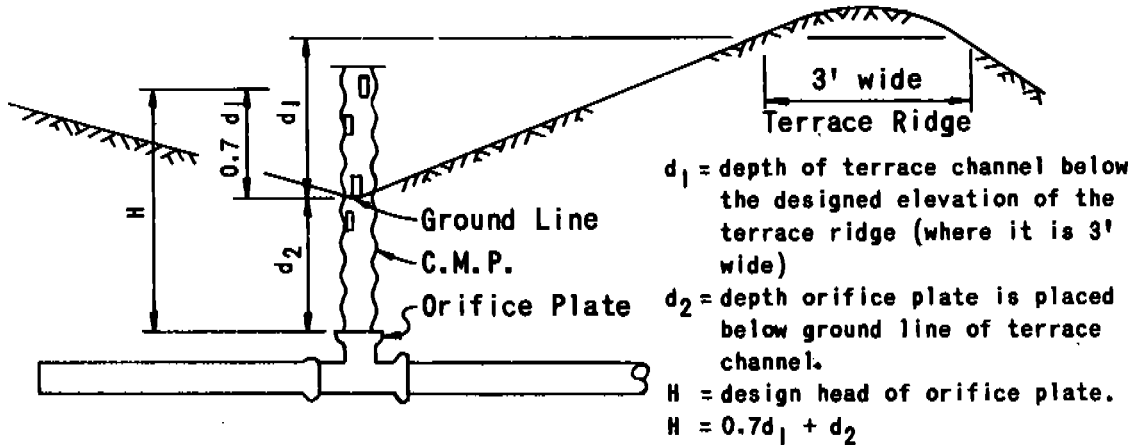

Figure 8-65 Design head for orifice plate

Example: Required discharge of .33 c.f.s. Height of terrace ridge = 3.0 feet. Orifice plate is 2.0 feet below channel bottom.

Head on orifice,  $H = (0.7 \times 3) + 2 = 4.1$  feet. From Exhibit 8-5, find that the orifice diameter for a discharge of .33 c.f.s. at a head of 4.1 feet equals 2.5 inches. Also, the pipe above the orifice must be at least a 6-inch diameter and the pipe below at least a 4-inch diameter.

Figure 8-66 shows typical details and placement of one type of intake. This intake is offset from the tile main by two sections of sewer pipe.

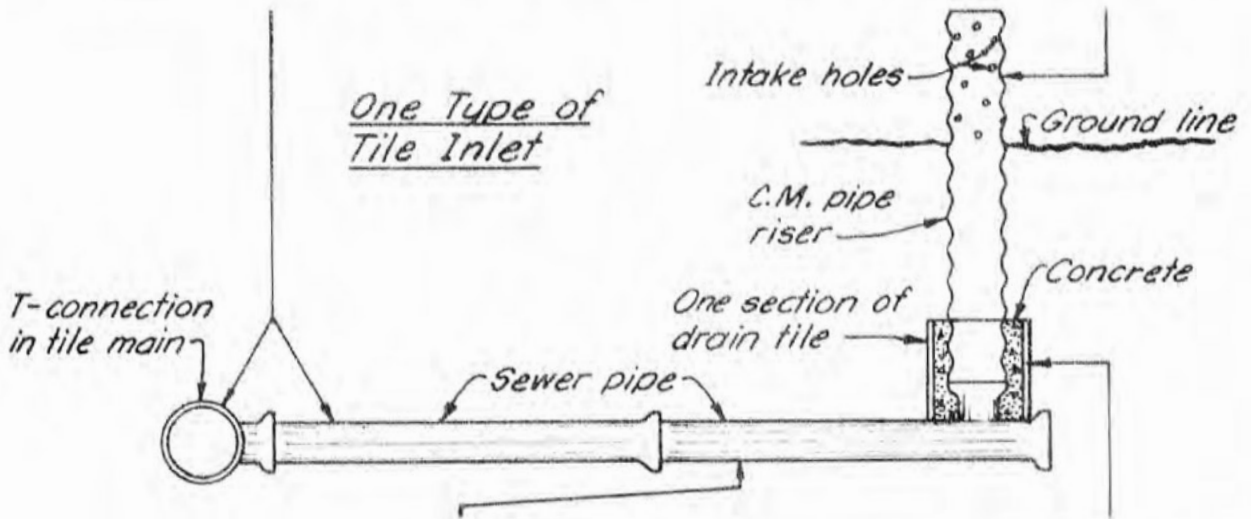
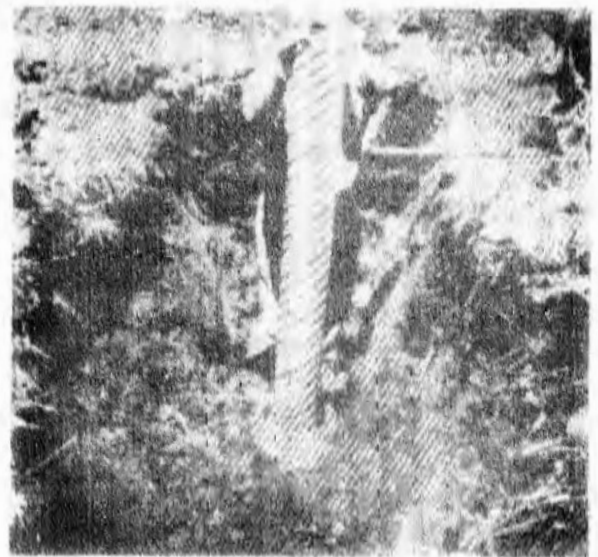
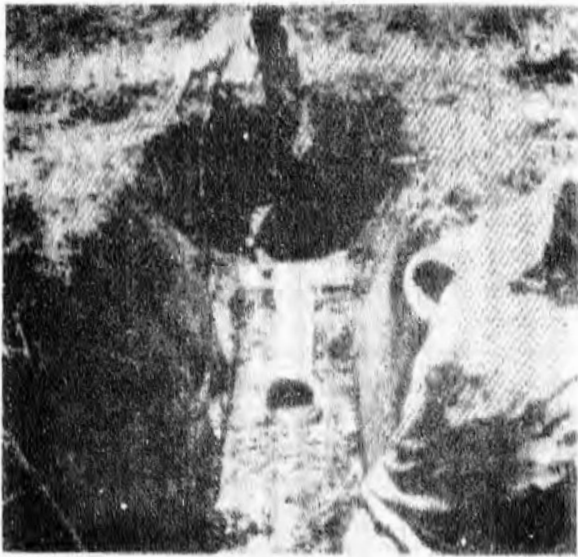

Figure 8-66 Typical details and placement of intake

## 12. CONSTRUCTION

The best planned terrace system, if poorly built, may result in the farmer being dissatisfied. Some of the difficulties of construction can be avoided by proper staking and explanation of the plans and specifications with the contractor and landowner.

CONSTRUCTION STAKING

Terraces fall into two construction categories, those with a uniform or balanced cross section and those requiring cuts and fills.

Balanced Cross-Section Terraces

The balanced cross-section terrace is one in which all earth is moved laterally in the cross section and the borrow at each station equals the fill. Thus, each cross section is balanced as far as earthmoving is concerned.

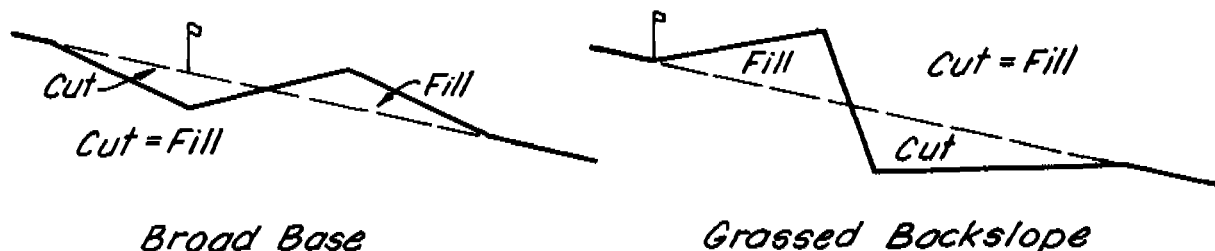

Figure 8-67 Staking for balanced sections

Generally, no construction stakes are needed for the balanced cross-section terrace other than the original layout stakes. See Figure 8-67. One exception is for a terrace with a grass back slope using borrow from below. Here it is advisable to mark with a plow or other tool the points along the terrace where the maximum cut occurs, which is the toe of the completed back slope. See Figure 8-68. This is especially important for new contractors.

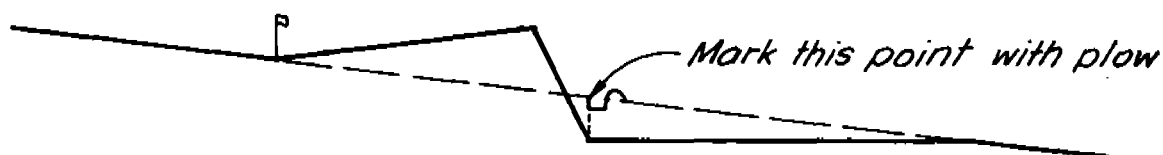

Figure 8-68 Marking toe of grass back slope

## Cut-and-Fill Terraces

This terrace has cuts and fills along its length that require earth to be moved longitudinally as well as laterally. It will have three basic types of cross section within its length: the balanced section, the excess borrow section, and the excess fill section.

### Balanced Section

For the balanced section only the layout stakes are normally required. However, since the balanced section occurs among nonbalanced sections, it will be necessary to stake the cut.

### Excess Borrow Section

Where heavy cuts are required, the cut should be marked on the layout stake. A construction stake also may be required. Figure 8-69 shows cutting directly beside the layout stake for the uphill borrow. If the cut is so deep that no fill or very little fill is required for the ridge, a hub or blue top should be set on the ridge showing the required height of fill.

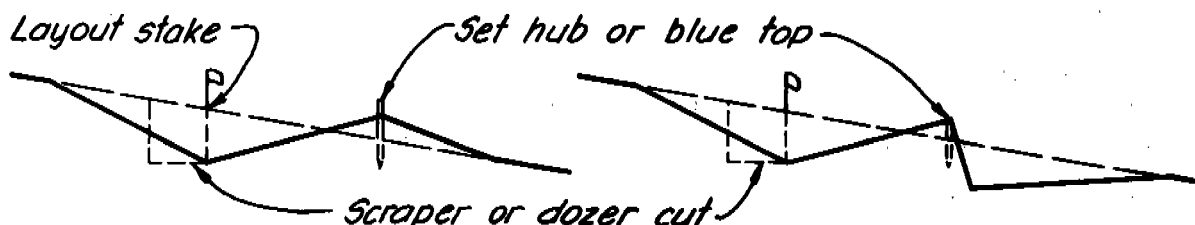

Figure 8-69 Location of stakes for excess borrow sections

A notation should be placed on the layout stakes for underground outlet terraces showing the cut or fill to both the completed channel and ridge.

### Excess Fill Section

Where large fills are required at a section, there will not be enough borrow, so borrow must be moved in. Borrow areas need not be confined to terrace channels. Additional borrow, as needed, may be obtained from adjacent high areas. The amount of cut or fill should be placed on the original layout stakes. (Figure 8-70)

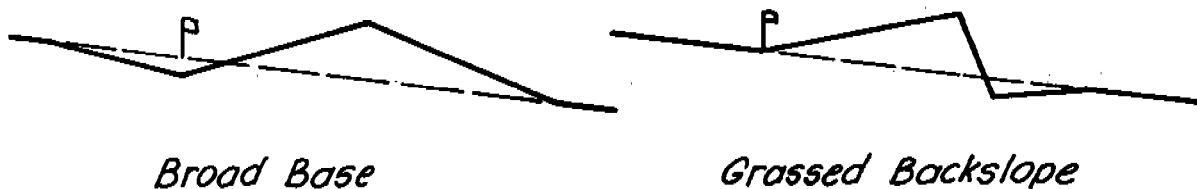

Figure 8-70 Location of stakes for excess fill sections

In some cases, fill at the section may be so high as to require a longer than usual front slope. When this happens the original stake will be covered during construction. Therefore, a reference stake should be set to reference both the alignment and grade. See Figure 8-71.

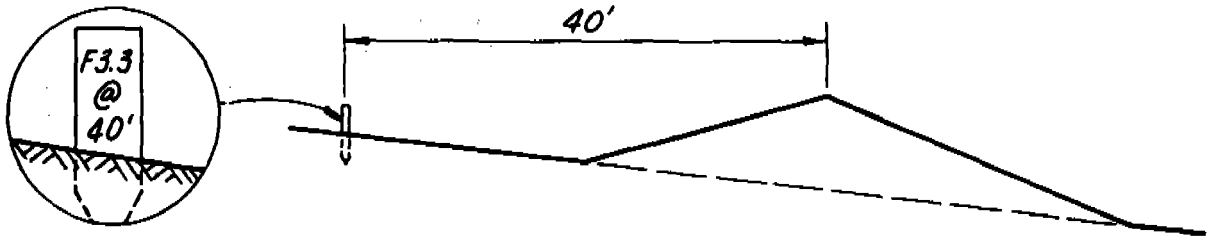

Figure 8-71 Reference stake

### PRESERVING THE SURVEY

It is necessary on jobs requiring heavy cuts and fills to set additional reference stakes to preserve the survey and guide the contractor. A hub or temporary bench mark should be established for each terrace, especially when it is a storage-type terrace. They will help reestablish the survey in the event some of the stakes are destroyed during construction.

### EARTHMOVING

In the earthmoving process, there are several factors which should be considered. These are the equipment used, the problem with trash and vegetation, the saving of topsoil, the rough grading and the finish grading.

#### Equipment

There are many types of equipment used to build terraces, ranging from farm equipment to large earthmoving tractors and scrapers. If the terrace has a broad base cross section and has no earth to be moved longitudinally along the terrace line, a bulldozer, road patrol, or disk terracer can be used.

If cuts and fills are involved, earth will need to be moved along the terrace, and hauling equipment will work best. The tractor and scraper best fit these needs. However, if length of haul does not exceed 150 feet, it may be just as economical to use a bulldozer.

#### Trash and Vegetation

Trash needs to be removed from the terrace base. Vegetation should be removed if it is excessive. Otherwise, it can be incorporated into the terrace base when the ground is scarified. Trash and heavy vegetation otherwise can cause a seepage problem on storage terraces, particularly where fills are high, the borrow is taken from the downhill side, and the back slope is left steep.

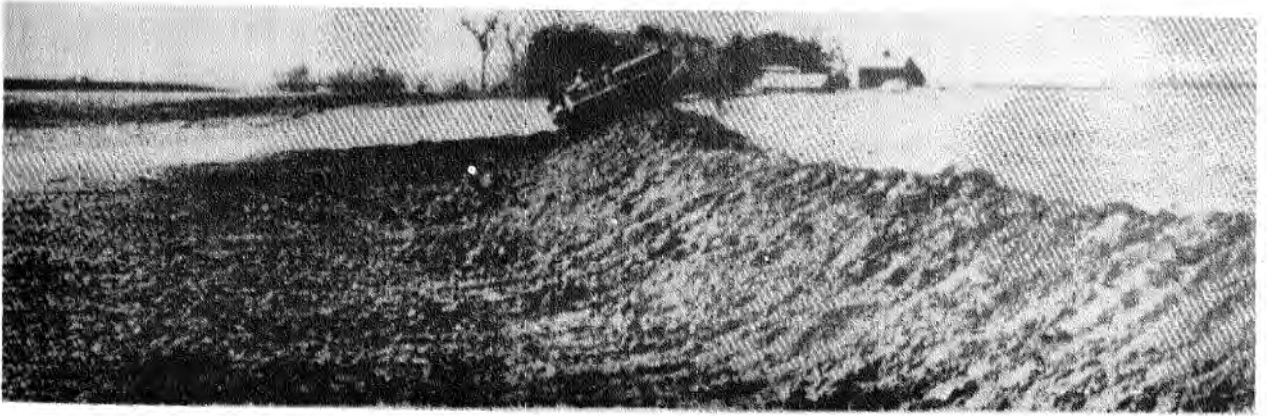

Bulldozer

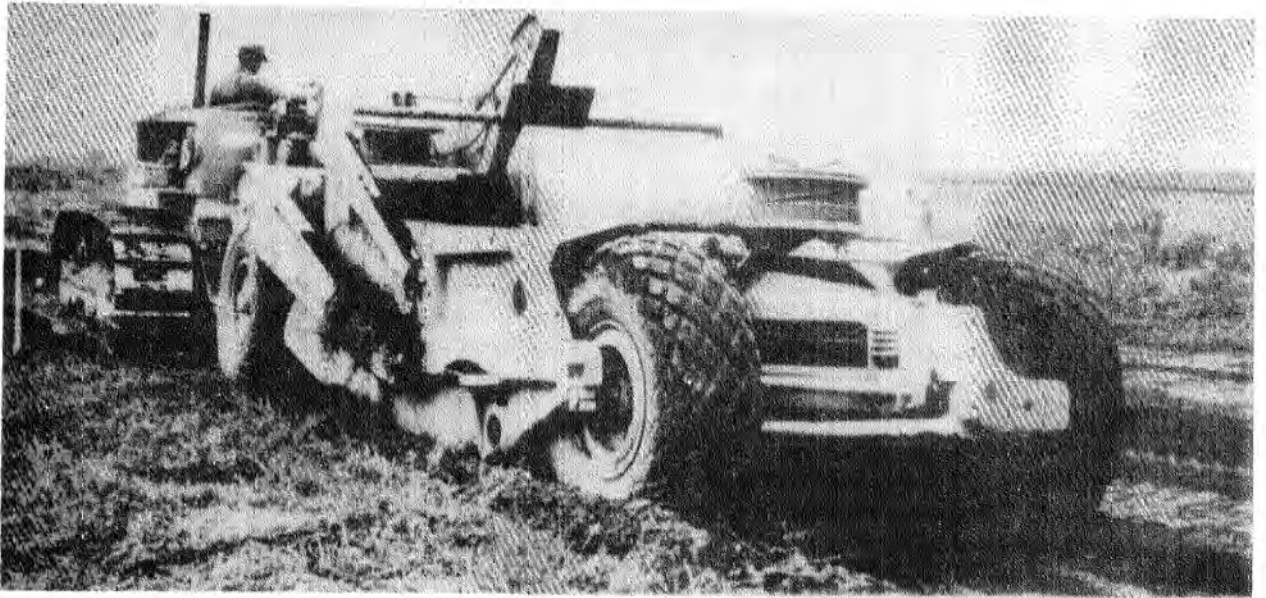

Scraper

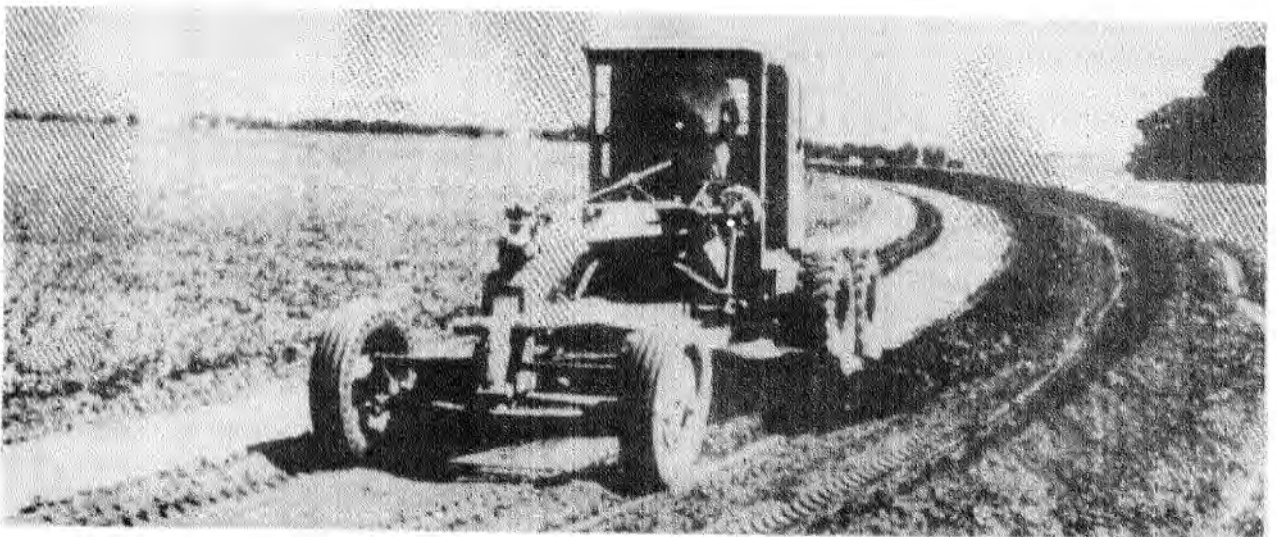

Road patrol

Figure 8-72 Types of earthmoving equipment for terraces

### Saving Topsoil

Where cuts are heavy and unfavorable subsoil will be exposed, it may be desirable to save the topsoil and respread it over the subsoil areas. One method is to plow the area where topsoil is to be saved, especially when the land is in legume or sod. Then, a dozer can push back the top eight inches of soil. The plowing makes it easier to move the topsoil and gives the dozer operator a guide depth.

### Rough Grading

It is in the rough grading process that the bulk of the earthmoving is done. It is important that the earth be moved correctly and efficiently. The rough-in work will vary considerably between a uniform terrace, a cut-and-fill terrace and a grass back slope.

### Balanced Section Terrace

Most terraces of this type are roughed in with a dozer. It is important that sufficient cut be made to obtain the desired cross section. If it is not, the error will probably not be discovered until after the terrace is finished.

### Cut-and-Fill Terrace

Experience on the part of the contractor is the best asset. In lieu of experience, the following steps should be helpful. These assume the use of a dozer and a tractor with a scraper.

1. Doze the earth into the ridge on those parts of the terrace which have balanced sections. Check the channel cut to make sure it is almost correct. Check the cut on the downhill borrow on terraces with grass back slopes.
2. Doze that portion of the earth which is available into the ridge on those sections where excess fill is required. Check to see that the specified amount of cut has been made.
3. Move the excess borrow from the heavy cut areas to the excess fill stations. The key to this type of construction is to build or create a guide by borrowing right down beside the channel stakes to get the channel to the exact elevation.

This requires checking at each station. Once this exact channel grade has been established, it is easy to see what remains to be done, and much easier to determine when the work is done correctly. This process gives a flat bottom 8 or 10 feet wide which is easily corrected later during the rest of the borrowing.

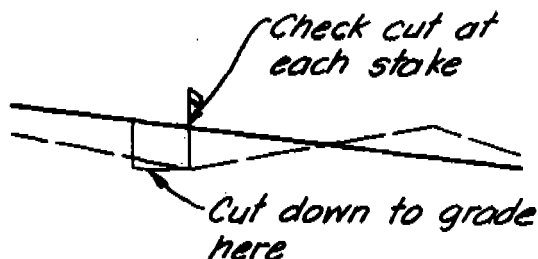
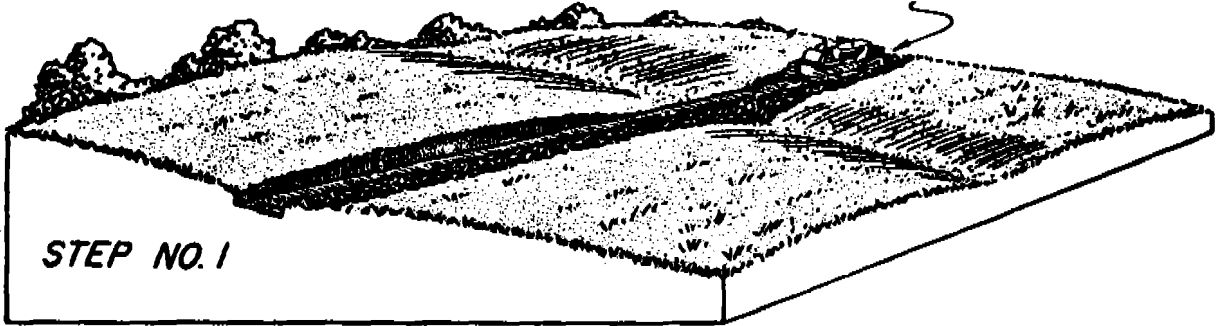
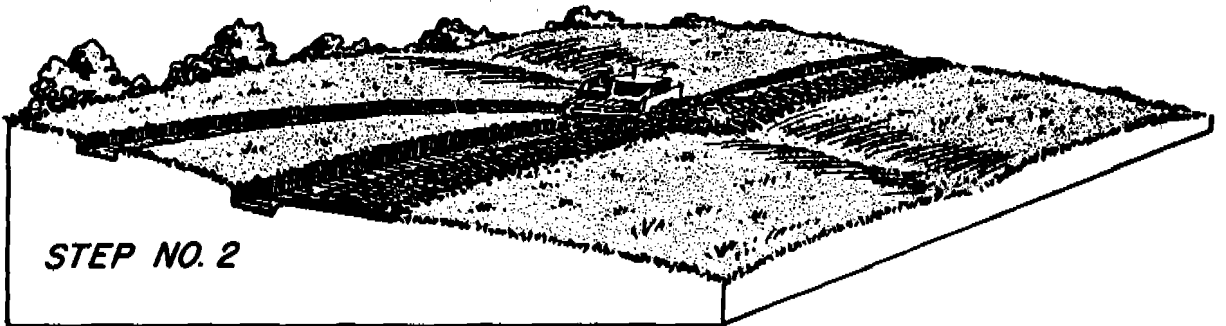

Figure 8-73 Guide for construction

MAKE COMPLETE CHANNEL CUT AS REQUIRED, USING NARROW TRENCH.



THE DEPTH OF CUT ALONG THE TRENCH WILL BE THAT SHOWN AS DEPTH OF CUT AT EACH 50 FT. STATION. THE EARTH FROM THIS CUT IS PUSHED INTO TERRACE RIDGE WHICH IS BUILT ACROSS THE LOW AREAS IN THE FIELD WHERE FILL IS REQUIRED IN THE TERRACE CONSTRUCTION.



CONSTRUCT THE SLOPE UPHILL FROM THE CHANNEL. START THE CUT UPHILL AT EACH STATION AT A DISTANCE OF DEPTH OF CUT, TIMES 10 PLUS 10 FT. THE FIRST CUT WILL BE PUSHED DIAGONALLY DOWNHILL TOWARD THE PART OF THE TERRACE REQUIRING FILL. SUCCESSIVE CUTS WILL BE MADE BY MOVING DOWNHILL UNTIL SLOPING INTERSECTS CHANNEL.

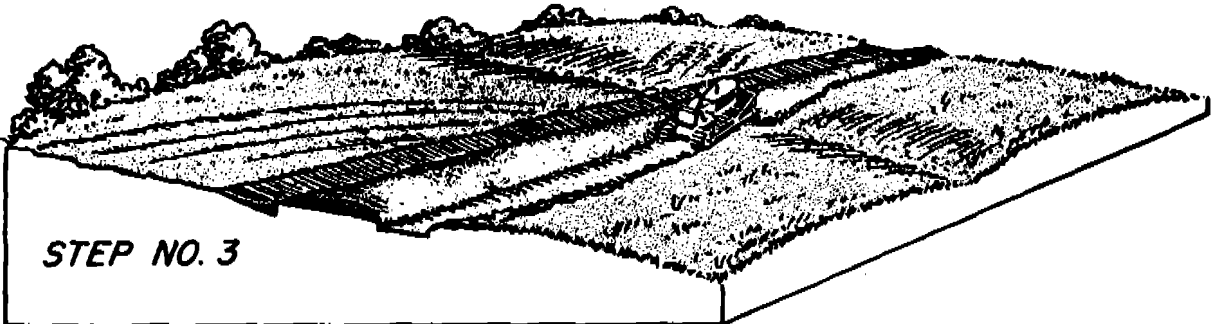

AFTER THE SLOPING IS COMPLETED ON THE UPHILL SIDE, THE CHANNEL FORESLOPE CAN BE PROPERLY SLOPED. ANY ADDITIONAL FILL NEEDED TO COMPLETE THE TERRACE CAN BE TAKEN FROM THE DOWNHILL SIDE OF THE TERRACE ON FIELD RIDGES.

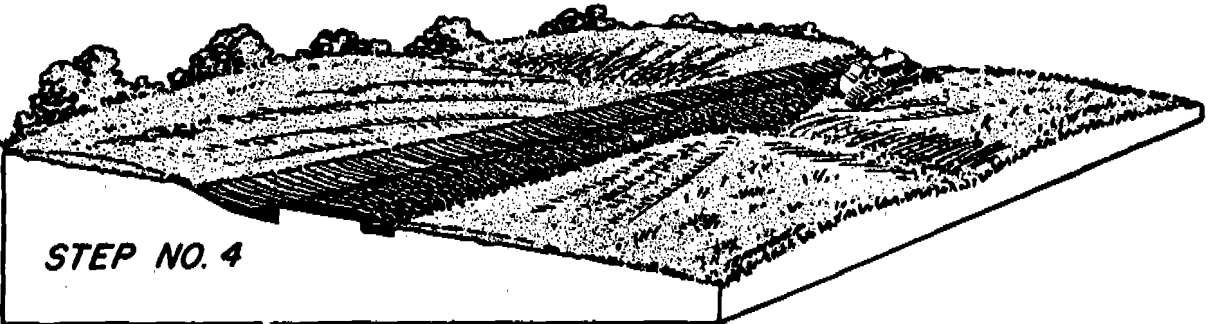

COMPLETE TERRACE BY DRESSING UP SLOPES WITH DOZER.

Figure 8-74 Using a dozer to build terraces having cuts and fills

Grass Back Slope

On the terraces with grass back slopes, most of the borrow will come from the downhill side. As much as possible should be dozed into place. When the haul gets too long, a tractor and scraper should be used instead of a bulldozer. The ridges and highs on the downhill side of the terrace are excellent places to borrow. Again, save topsoil if necessary.

Some contractors have a tendency to want to use the shortest haul distance instead of using the ridges and high points for borrow areas. This practice will result in a back slope of varying width along the terrace, and the system will have short rows and poor farmability. See Figure 8-75.

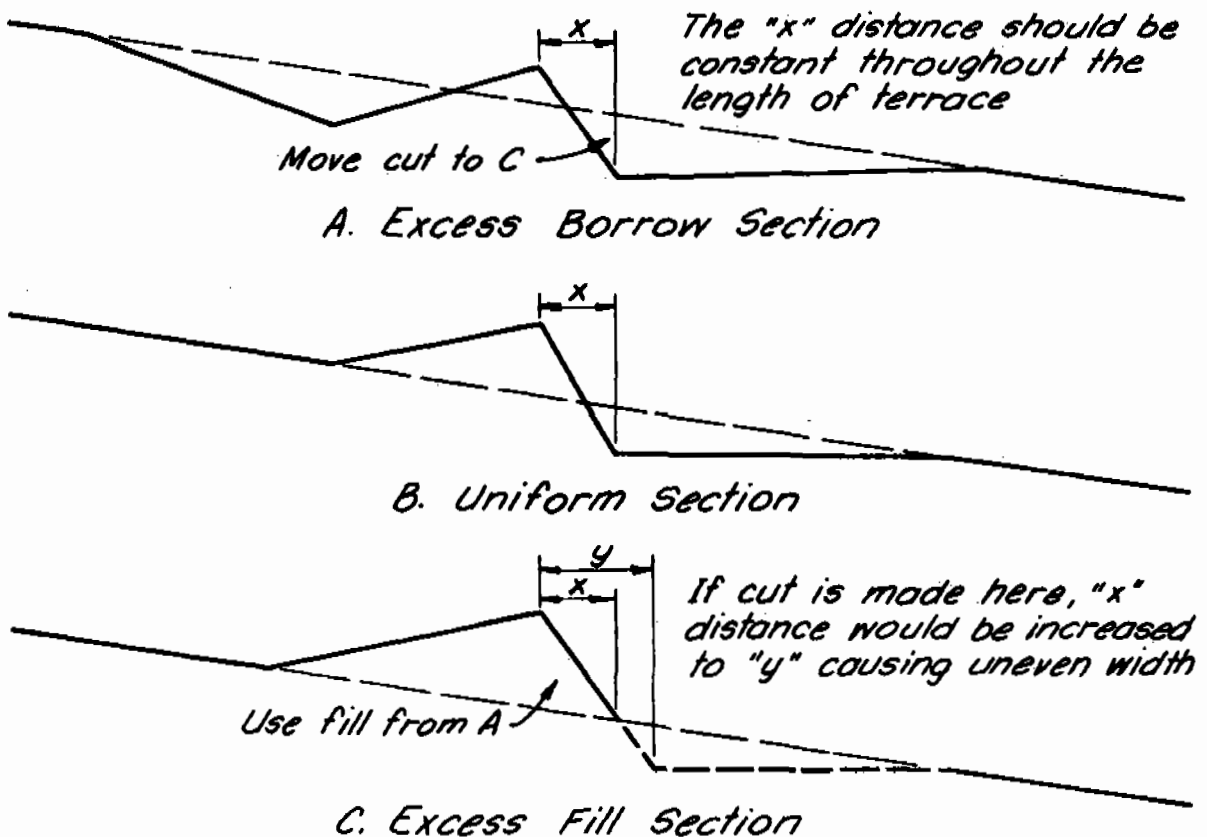

Figure 8-75 Methods of borrow

Rough Grading Check

The final step in rough grading is to make sure there is enough earth in the ridge to bring it up to height and cross section, considering settlement and compaction. It is important that the contractor check the ridge for approximate height before proceeding to the finishing operation. On level terraces and underground outlet terraces the ridge should be level throughout its length (except in those few cases where the terrace is quite long and there is no storage in the outer ends of the terrace).

FINISHING TERRACE CROSS SECTION

Finishing is usually done with a dozer, but can be done with a motor grader. Cut slopes, front slopes and back slopes should be finished to their planned dimensions. Parallel terraces should be finished in parallel, as any mistake in alignment on a terrace affects two terrace intervals. See Figure 8-76.

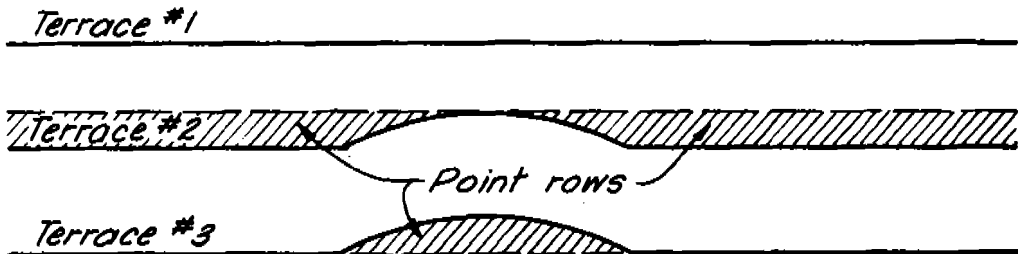

Figure 8-76 Short rows are created when parallel terraces are not built as staked

SMOOTHING AND SHAPING

Land shaping and smoothing of the ground surface between terraces is an important operation for a successful terrace system. It can be done best with a land leveler or land plane (Figure 8-77). If the land is not smooth, water accumulates in low places causing the rows to break and silt bars to form in the terrace channel, thereby reducing channel capacity. Smoothing the land surface reduces erosion between terraces, conserves moisture, provides for better farming by making it possible to grow more uniform crops and to use modern equipment more efficiently.

A more uniform job of fertilizing results on smooth, even fields since the applicators are held at a constant depth. The plowing operation is better since the shares operate at a constant depth and do not sink lower in wet spots nor come closer to the surface on high, hard, dry spots. The planter puts the seed into the ground at a constant and correct depth. The smooth field then provides for uniform stand, more even growth throughout the year, and uniform maturity at harvest time.

A smooth seedbed permits closer and more complete cultivation since the tractor and cultivator gage wheels are working on a smooth surface.

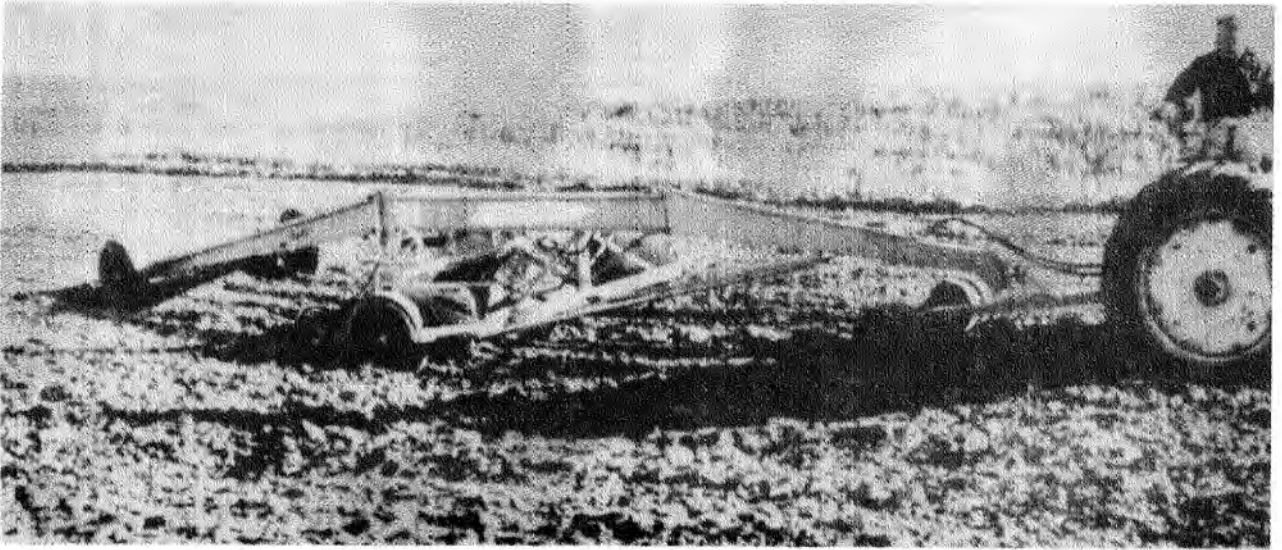

Shaping **Between Terraces** with a Land Leveler

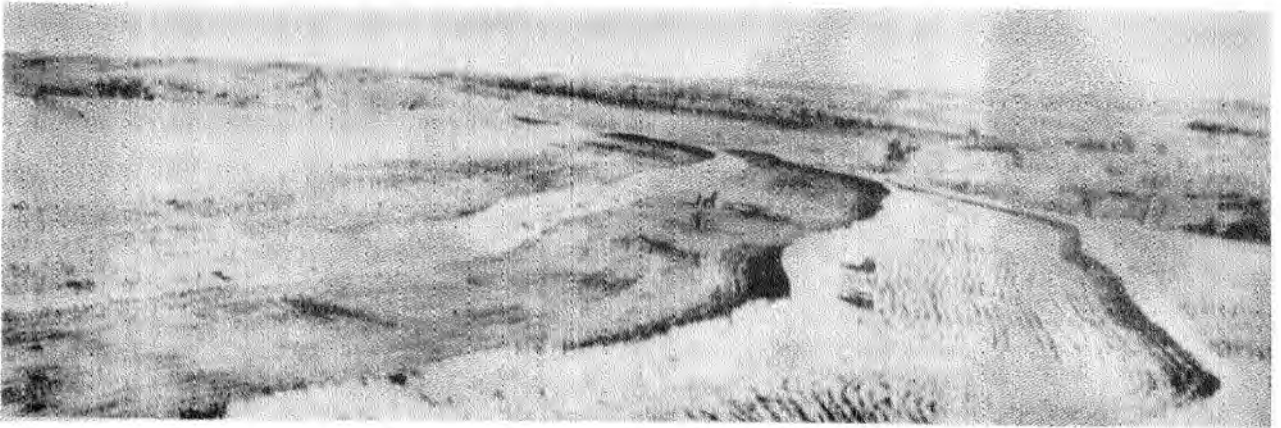

Comparison of Smoothed and Rough Terrace Intervals

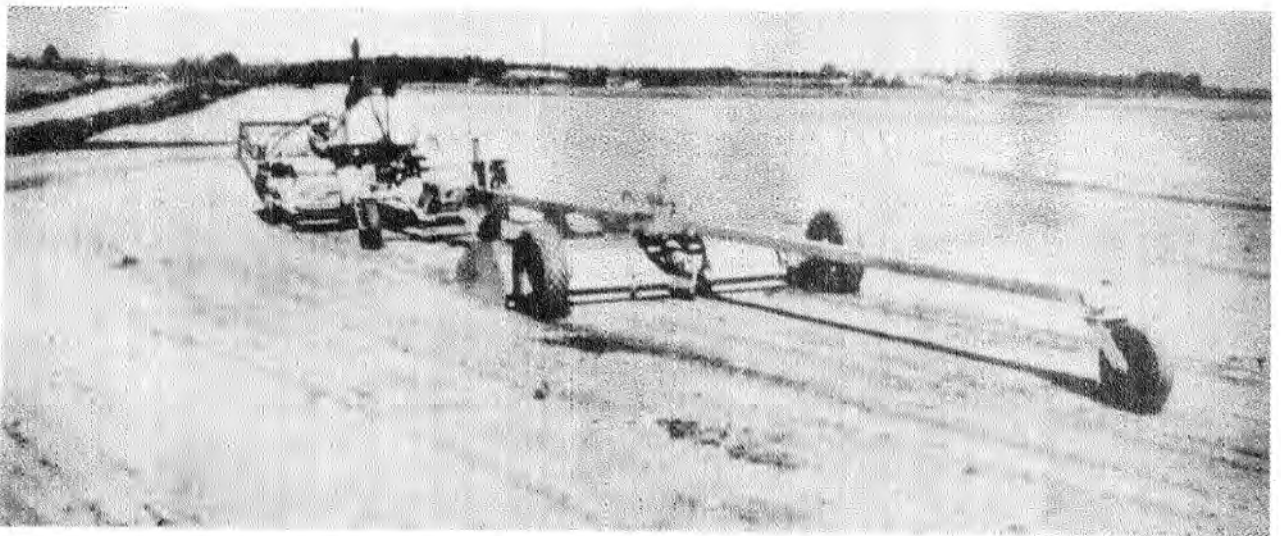

Finishing a Terraced Field with a Land Plane

Figure 8-77 Equipment for land smoothing

When combining close-growing crops, such as soybeans, field loss will be reduced because the header bar can be set lower. Mowing, raking, harvesting or baling is easier and faster on a smooth field.

All draws and depressions should be filled either prior to terrace construction or during construction. After the terraces are built the area between the terraces should be plowed and smoothed to eliminate all minor surface irregularities. The smoothing operation can best be done with some type of land leveler or plane.

#### INSTALLATION OF UNDERGROUND OUTLET

Underground outlets are usually constructed of regular field drain tile. At least part of the line will be on steep grades and should be installed as a tile main. (See Chapter 14 of this manual.) Existing tile lines that are to be used as outlets should also meet these provisions.

The Underground outlet used to dispose of impounded water from a terrace is, in fact, a mechanical spillway through an earthen embankment. In order for this spillway to function properly and not be washed out proper material selection and good construction techniques are required. It is recommended that tile outlets be installed one year prior to installing the terraces. This will minimize the possibility of washout along the tile under the terrace ridge when the terraces are built.

If it is necessary to install the tile outlet at the time the terraces are built, special provisions should be made for the section of tile through the terrace ridge. Extra strength field tile, sewer tile or continuous or sealed joint conduit should be laid under the terrace ridge. The sides of the trench under the ridge should be sloped before backfilling. The backfill should be of selected material with the proper moisture content. The backfill should be placed in layers not more than six inches thick and each layer mechanically compacted. Another accepted method of backfilling is shown in Figure 8-78.

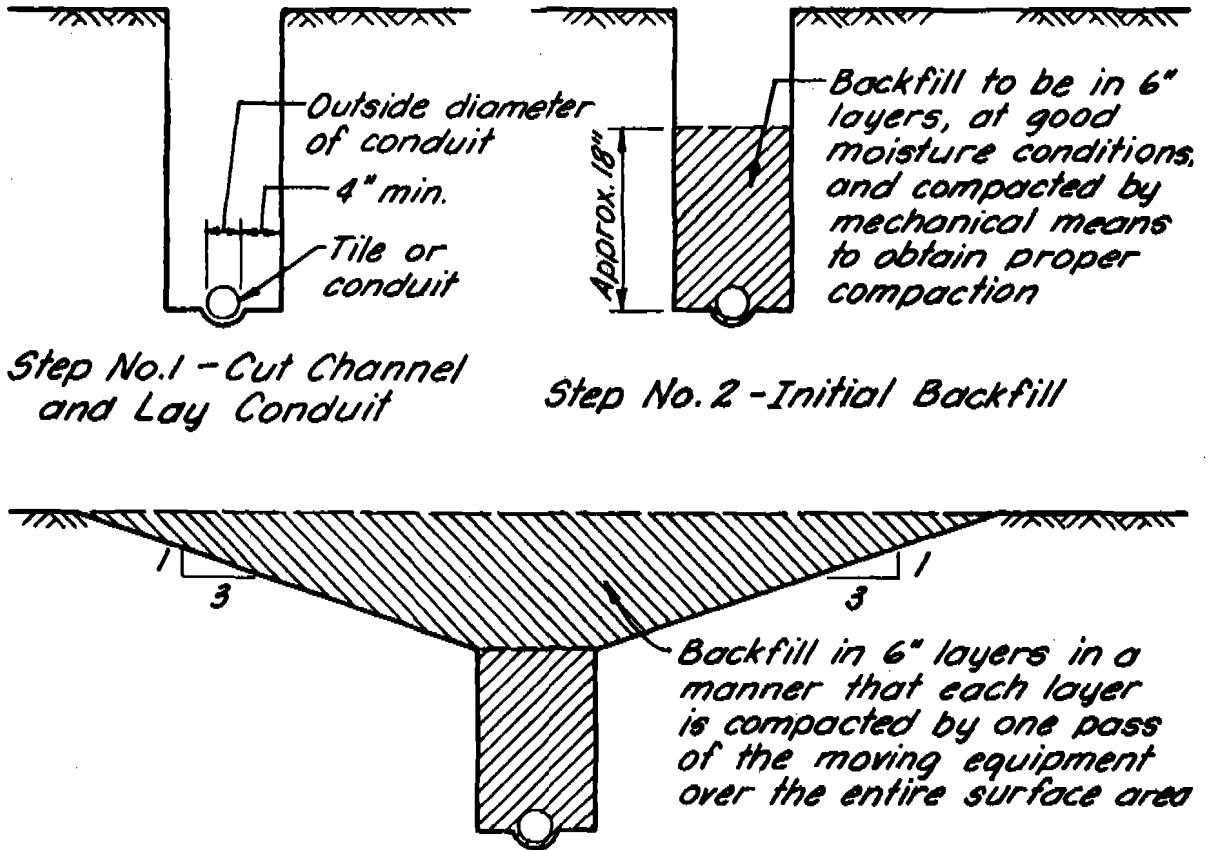

*Step No. 1 - Cut Channel and Lay Conduit*

*Step No. 2 - Initial Backfill*

*Step No. 3 - Slope Banks and Backfill*

Figure 8-78 A method of backfilling the underground conduit trench

### 13. FARMING

#### LAND PREPARATION

After the terracing is completed there are certain jobs which should be done.

1. Fertilize the entire disturbed area, including the terrace, generally at about the same rate as for the rest of the field.
2. On heavy cuts, apply additional fertilizer at least twice the rate as for the field.
3. Seed the back slope on those terraces which have steep back slopes in accordance with recommendations in the Work Unit Technical Guide.
4. The entire terraced area, except the grass back slope, should be plowed to loosen the soil compacted by the earthmoving machinery. The quicker it can be plowed the better since this

will give it a chance to mellow before preparing the seedbed for the general crop. Since plowing is the primary maintenance practice, see section on Maintenance for additional comments.

## PLANTING

Where terraces are parallel, there is little trouble in planting. If the terraces are not the same length, (where one terrace stops and another continues) it will be necessary to plant parallel to the longer line in order to keep rows parallel. This is best done by planting from the longer terrace to the shorter terrace. If this is not done, point rows will develop. If it is not possible to plant from the longer terrace line toward the shorter, it will be necessary to plant parallel to the longer line.

If terraces are not parallel, correction areas are necessary and these require special planting. The short rows should be confined to the area between the terraces and not on the terrace itself. When planting and cultivating a correction area it will be necessary to turn on the crop unless grass turn strips are provided. Small narrow correction areas are best left in grass.

The following sketches show methods of planting when the spacing between terraces changes. The correct method of planting to and from a grassed ridge is also shown.

- ① FIRST-PLANT PARALLEL FROM RIDGE UP TO BOTTOM OF GRASSED SLOPE
- ② THEN PLANT OUT REMAINING AREA, PLANTING UPHILL AND PARALLEL WITH BASE OF GRASSED BACKSLOPE

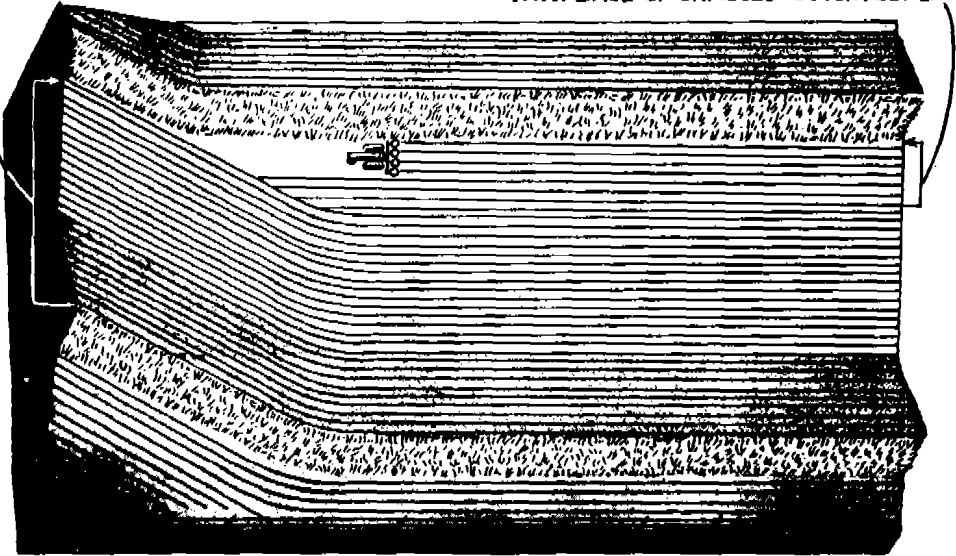

Planting correction areas between grassed back slope terraces

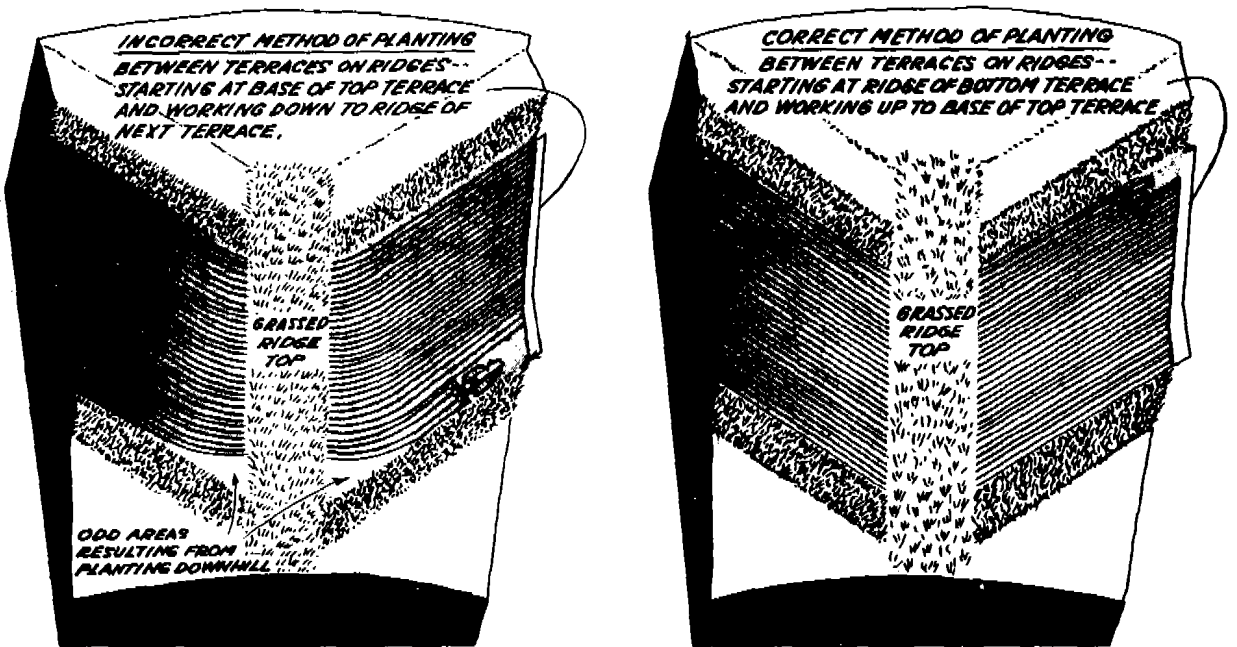

Planting at a grass turn strip - same technique for both grassed back slope and broad base sections

Figure 8-79 Planting grassed back slope terraces

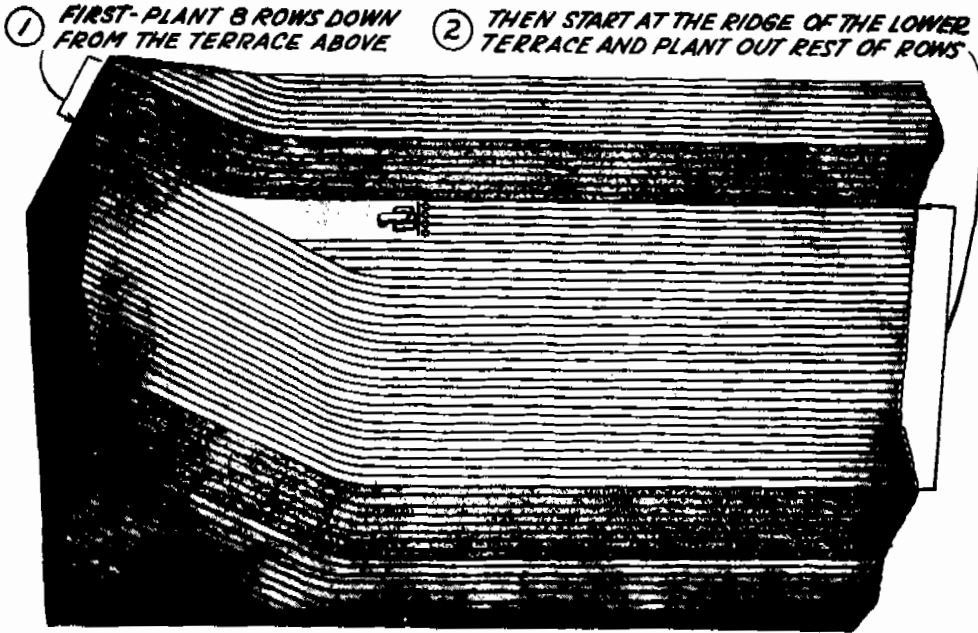

Figure 8-80 Planting correction areas between broad base terraces

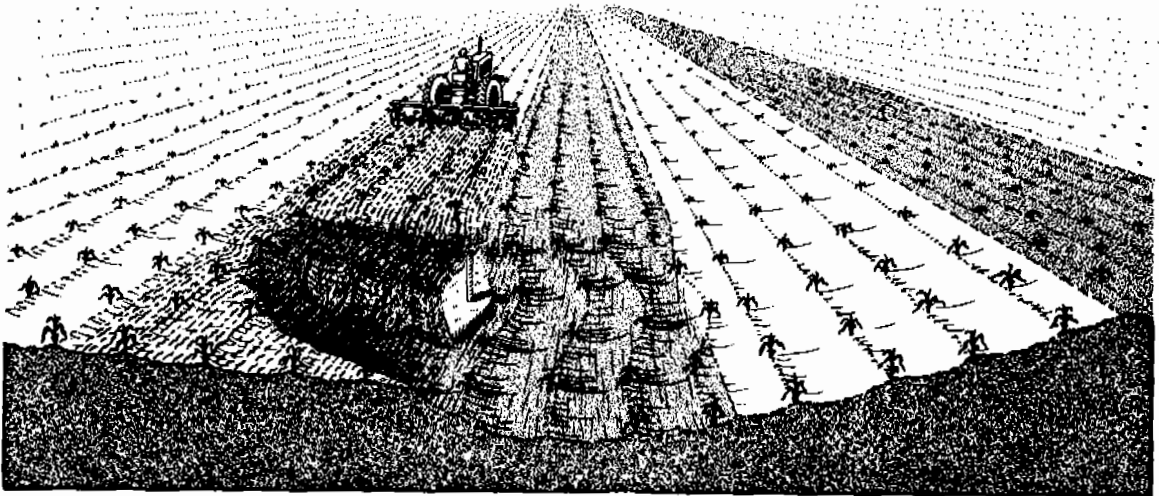

Figure 8-81 A method of intake protection from machinery by maintaining an area of sod around the intake

## 14. MAINTENANCE

BROAD BASE TERRACE SYSTEMS

Terrace capacity can be maintained generally by routine plowing. There is really no satisfactory way to plow terrace land except with the two-way (reversible) plow. With this plow, soil can be thrown either to the right or to the left depending upon choice. To maintain the cross section of the terraces and the terrace interval as it was after construction, most of the area should be plowed uphill.

Figure 8-82, exaggerated for clarity, shows what happens to a terraced field after a number of plowings with conventional plows. Even though the dead furrows are shifted from one place to another it is not possible to avoid throwing soil both downhill and uphill. This causes benching of the terrace interval.

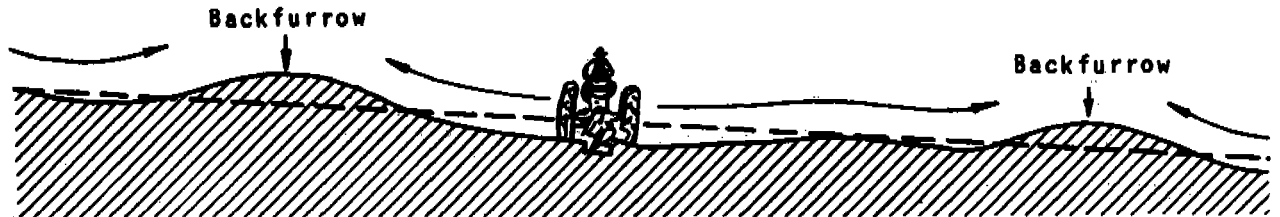

By using a one-way plow the profile becomes dished and after a number of plowings the terraces become 'benched' . . . Arrows indicate direction dirt is thrown; the dashed line indicates natural ground level.

Figure 8-82 Results of plowing with a one-way plow

With the two-way plow, the front slope of each terrace should be plowed toward the ridge. The remaining area from the channel to the ridge of the next terrace generally should be plowed uphill. See Figure 8-83. This will tend to keep up with any inter-terrace soil movement downslope.

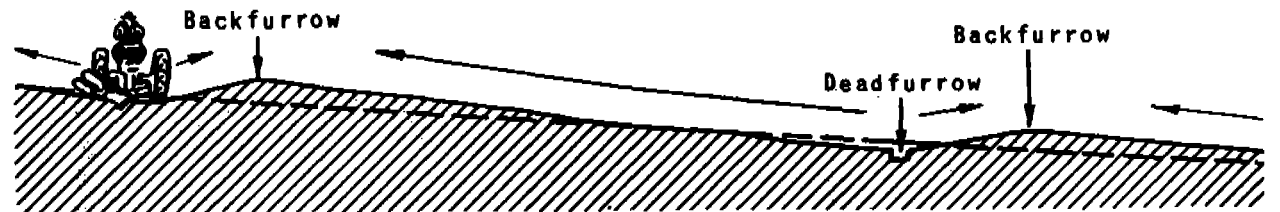

By using a two-way plow the profile remains almost constant . . . Arrows indicate direction dirt is thrown; the dashed line indicates natural ground level.

Figure 8-83 Results of plowing with a two-way plow

Unfortunately, there are very few farmers with two-way plows. The trend in farm machinery is to larger tractors pulling 5-, 6-, and 8-bottom standard plows. The best that can be done with a standard plow is to plow so that dead furrows do not fall in the same place too often. Either the terrace ridge should be raised by backfurfrowing each time the field is plowed, or the channel deepened by dead furrowing. One of these two is necessary. If the terrace height or capacity is very low, place both a dead furrow in the channel and a backfurfrow on the ridge. This is best accomplished with the conventional plow by the "Three land method." With this method the area between terraces is divided into three "lands" and each land is plowed separately in progressive steps as illustrated in Figure 8-84.

#### TERRACES WITH GRASS BACK SLOPES

Maintenance of terraces with grass back slopes is considerably different. Plowing is easier, in that the land can be plowed more like level land, one year with the dead furrow in the center and the next year with the backfurfrow in the center. This will not maintain terrace height, but will retain the general cross section of the terrace interval. The terrace ridge will occasionally have to be raised by extra plowing, or by construction equipment. See Figure 8-85.

A critical area to maintain on this type of terrace is the grass back slope. A good sod should be established and maintained. Trees and brush growth should be controlled by spraying, or mowing if possible. Gophers and burrowing rodents should be eliminated from the slope. The slope should be fertilized occasionally to maintain a vigorous sod.

#### MAINTENANCE BY HEAVY EQUIPMENT

As farms increase in size and as farm machinery becomes larger and more specialized (less useful for terrace maintenance), maintenance by construction machinery is both desirable and recommended. The road patrol is an excellent tool for this type of reconstruction. The trend in many areas is for farmers to hire terrace maintenance rather than to do it themselves.

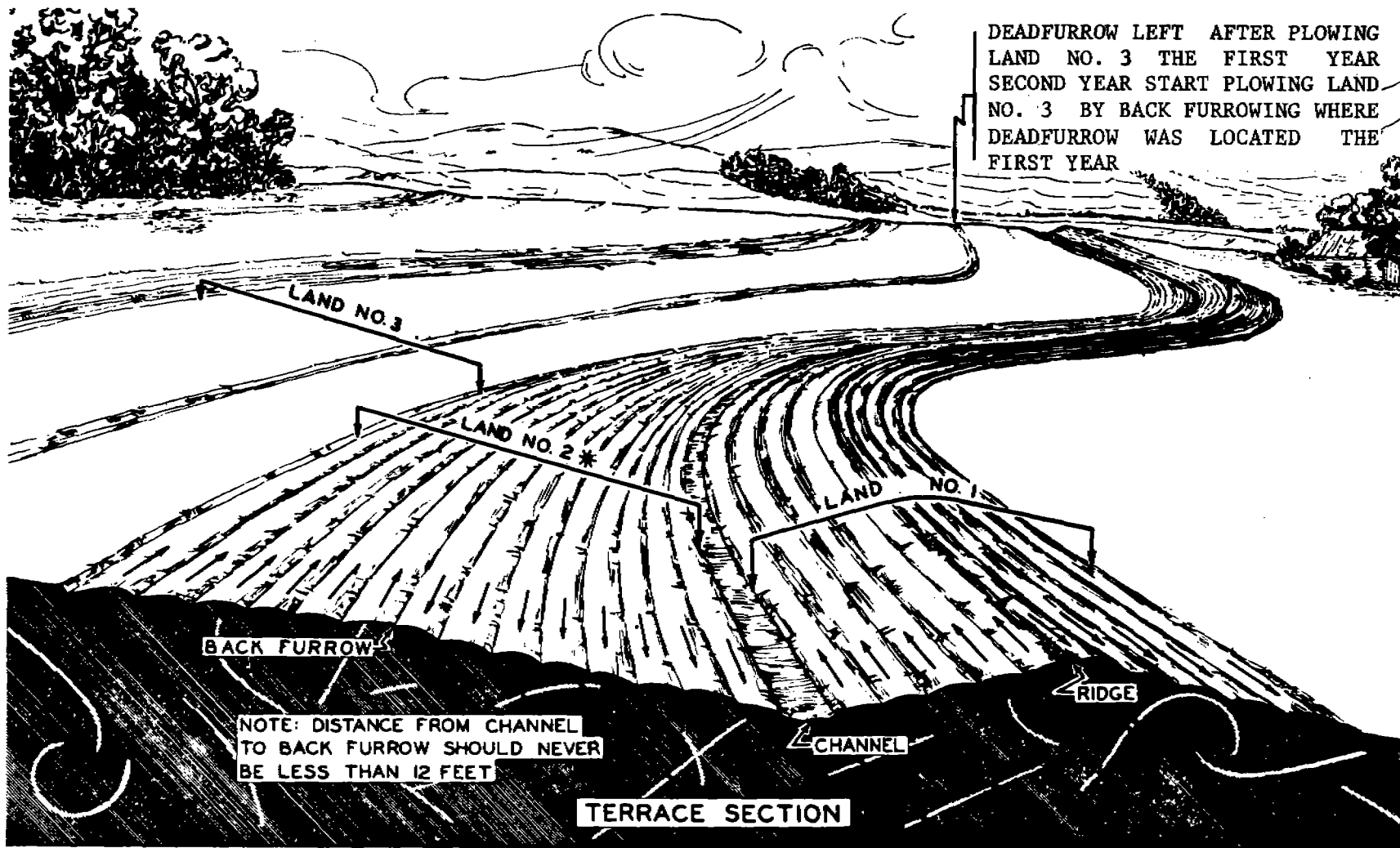

- ARROWS INDICATE DIRECTION IN WHICH FURROWS ARE MADE
- \* WIDTH OF LAND NO. 2 SHOULD BE VARIED EACH PLOWING

Figure 8-84 The three land method of plowing terraces

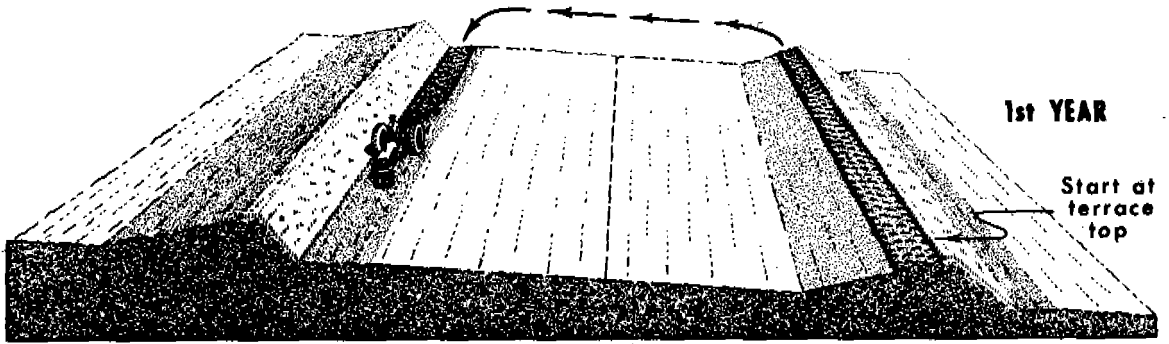

First year plowing

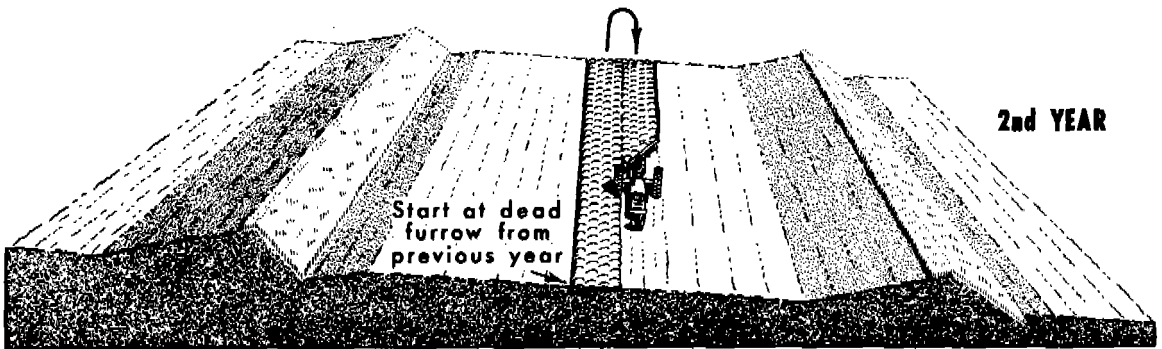

Second year plowing

Figure 8-85 A method of plowing grass back slope terraces

Depth of cut in channel (feet)

Slope of land (Percent)	Depth of flow (feet)								
	0.7	0.8	0.9	1.0	1.1	1.2	1.3	1.4	1.5
1	0.5	0.6	0.6	0.7	0.7	0.8	0.8	0.9	0.9
2	0.6	0.7	0.7	0.8	0.8	0.9	0.9	1.0	1.0
3	0.7	0.7	0.8	0.8	0.9	0.9	1.0	1.0	1.1
4	0.8	0.8	0.9	0.9	1.0	1.0	1.1	1.1	1.2
5	0.8	0.9	0.9	1.0	1.0	1.1	1.1	1.2	1.2
6	0.9	0.9	1.0	1.0	1.1	1.1	1.2	1.2	1.3
8	1.0	1.1	1.1	1.2	1.2	1.3	1.3	1.4	1.4
10	1.2	1.2	1.3	1.3	1.4	1.4	1.5	1.5	1.6
12	1.3	1.4	1.4	1.5	1.5	1.6	1.6	1.7	1.7
14	1.5	1.5	1.6	1.6	1.7	1.7	1.8	1.8	1.9

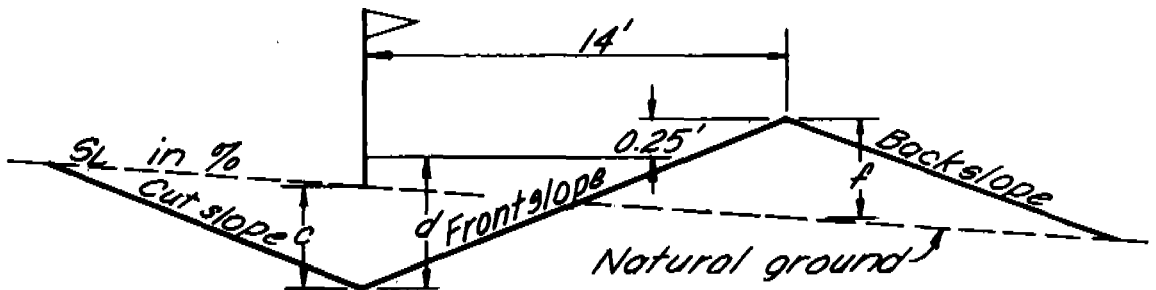

1. Stake line is 14 feet uphill from the completed terrace ridge and will be the centerline of completed "V" channel.
2.  $c$  - cut in channel in feet, measured from the natural ground at the stake line to the completed channel bottom.
3.  $d$  - depth in feet, measured from the completed channel bottom to design height of terrace; 0.25 foot of freeboard allowed above design height to extreme height of terrace.
4. Excavation equals earthfill; in other words, this is a balanced cross section, and the cut equals the fill. Cut slope and back slope are equal in length; therefore, " $c$ " equals " $f$ ."

Exhibit 8-1 Cut in channel in feet for broad base terraces

NATURAL STORAGE ABOVE TERRACES  
IN CU. FT. PER LINEAL FOOT

$s_L$	1%	2%	3%	4%	5%	6%	8%	10%	12%	14%	16%	18%
	14' Front Slopes											
0.1	1	1	1	1	1	1	1	1	1	1	1	1
0.2	3	2	2	2	2	2	2	2	2	2	2	2
0.3	7	4	4	3	3	3	3	3	3	2	2	2
0.4	11	7	6	5	4	4	4	4	4	3	3	3
0.5	16	10	8	7	6	6	5	5	5	4	4	4
0.6	22	13	10	9	8	7	6	6	6	6	5	5
0.7	29	17	13	11	10	9	8	7	7	7	6	6
0.8	38	22	16	14	12	11	10	9	8	8	8	7
0.9	47	27	20	16	14	13	11	10	10	9	9	9
1.0	57	32	24	20	17	15	13	12	11	11	10	10
1.1	68	38	28	23	20	18	15	14	13	12	12	11
1.2	80	44	32	26	23	20	17	16	14	14	13	12
1.3	94	51	37	30	26	23	20	18	16	15	14	14
1.4	108	59	43	34	29	26	22	20	18	17	16	15
1.5	123	67	48	39	33	29	25	22	20	19	18	17
1.6	139	75	54	43	37	33	27	24	22	20	19	18
1.7	156	84	60	48	41	36	30	26	24	22	21	20
1.8	175	94	67	53	45	40	33	29	26	24	23	22
1.9	194	104	74	58	49	43	36	31	28	26	25	24
2.0	214	114	81	64	54	47	39	34	31	28	26	25
2.1	235	125	88	70	59	51	42	37	33	30	28	27
2.2	257	136	96	76	64	56	46	40	36	32	31	29
2.3	281	148	104	82	69	60	49	43	38	35	33	31
2.4	305	161	113	89	74	65	53	46	41	37	35	33
2.5	330	174	122	96	80	70	57	49	44	40	37	35
2.6	356	187	131	103	86	75	60	52	46	42	39	37
2.7	383	201	140	110	92	80	65	55	49	45	42	39
2.8	412	216	150	117	98	85	69	59	52	48	44	41
2.9	441	231	161	125	104	90	73	62	55	50	47	44
3.0	471	246	171	134	111	96	77	66	58	53	49	46
	28' Front Slopes											
3.0	449	223	147	109	85	69	48	37	26	18	12	7
3.2	511	254	168	124	97	79	56	41	31	23	16	11
3.4	577	287	190	141	111	90	64	48	36	28	20	14
3.6	647	322	213	158	125	102	73	55	42	33	25	18
3.8	721	359	238	177	139	114	82	62	48	38	29	22
4.0	799	398	264	196	155	127	92	70	55	43	34	27
5.0	1250	623	414	309	245	202	148	115	92	76	62	52
6.0	1800	898	597	446	355	294	217	170	138	115	97	82
7.0	2450	1220	814	609	485	402	298	235	192	161	137	118
8.0	3200	1600	1060	796	635	527	392	310	255	215	184	160
9.0	4050	2020	1350	1010	805	669	498	395	326	276	237	207

- Storage shown is natural storage, storage above natural ground on uphill side of the terrace. Does not include any storage which might result from excavation.
- $s_L$  - slope of the land where the terrace is built.
- $d$  - depth of water in the completed terrace, measured from the natural ground at the stakeline to the top of the terrace ridge.
- This table is based entirely on a stakeline placed 14 ft. uphill from the completed terrace ridge. Stated another way, peak of the terrace ridge is always built 14 ft. downhill from stakeline for both 14' and 28' frontslopes.

17. LAND SLOPE

Combined Natural and Excavated Storage in Cubic Feet Per Lineal Foot

d <sup>c</sup>	0.0	0.1	0.2	0.3	0.4	0.5	0.6	0.7	0.8	0.9	1.0	1.1	1.2	1.3	1.4	1.5	1.6	1.7	1.8	1.9	2.0	.1	.2	.3	.4	.5	.6	.7	.8	3.0	
0.1	1	1	1	1	1	1	1	1	1	1	1	1	1	1	1	1	1	1	1	1	1	1	1	1	1	1	1	1	1	1	
0.2	3	2	2	2	2	2	2	2	2	2	2	2	2	2	2	2	2	2	2	2	2	2	2	2	2	2	2	2	2	2	2
0.3	7	4	3	2	2	2	2	2	2	2	2	2	2	2	2	2	2	2	2	2	2	2	2	2	2	2	2	2	2	2	2
0.4	11	7	5	4	3	3	3	3	3	3	3	3	3	3	3	3	3	3	3	3	3	3	3	3	3	3	3	3	3	3	3
0.5	16	12	8	6	5	4	4	4	4	4	4	4	4	4	4	4	4	4	4	4	4	4	4	4	4	4	4	4	4	4	4
0.6	22	17	12	9	7	6	5	5	5	5	5	5	5	5	5	5	5	5	5	5	5	5	5	5	5	5	5	5	5	5	5
0.7	29	23	18	13	10	8	7	6	6	6	6	6	6	6	6	6	6	6	6	6	6	6	6	6	6	6	6	6	6	6	6
0.8	38	30	24	18	14	11	9	8	8	8	8	8	8	8	8	8	8	8	8	8	8	8	8	8	8	8	8	8	8	8	8
0.9	47	38	31	25	19	15	12	10	9	9	9	9	9	9	9	9	9	9	9	9	9	9	9	9	9	9	9	9	9	9	9
1.0	57	48	39	32	26	20	16	13	11	10	10	10	10	10	10	10	10	10	10	10	10	10	10	10	10	10	10	10	10	10	10
1.1	68	58	48	40	33	27	21	17	14	12	11	11	11	11	11	11	11	11	11	11	11	11	11	11	11	11	11	11	11	11	11
1.2	80	69	59	49	41	34	28	23	18	16	14	13	13	13	13	13	13	13	13	13	13	13	13	13	13	13	13	13	13	13	13
1.3	94	81	70	59	50	42	35	29	24	20	17	15	14	14	14	14	14	14	14	14	14	14	14	14	14	14	14	14	14	14	14
1.4	108	94	82	71	60	51	43	36	30	25	21	18	16	16	16	16	16	16	16	16	16	16	16	16	16	16	16	16	16	16	16
1.5	123	109	95	83	72	61	52	44	37	31	26	22	20	18	17	17	17	17	17	17	17	17	17	17	17	17	17	17	17	17	17
1.6	139	124	109	96	84	73	62	53	45	38	32	28	24	21	20	19	19	19	19	19	19	19	19	19	19	19	19	19	19	19	19
1.7	156	140	125	110	97	85	74	64	54	47	40	34	29	25	23	21	21	21	21	21	21	21	21	21	21	21	21	21	21	21	21
1.8	175	157	141	125	111	98	86	75	65	56	48	41	35	31	27	24	23	22	22	22	22	22	22	22	22	22	22	22	22	22	22
1.9	194	175	158	142	126	112	99	87	76	66	57	49	42	37	32	29	26	25	24	24	24	24	24	24	24	24	24	24	24	24	24
2.0	214	195	176	159	143	127	113	100	88	77	67	58	51	44	38	34	30	28	26	26	26	26	26	26	26	26	26	26	26	26	26
2.1	235	215	195	177	160	144	128	114	101	89	78	69	60	52	46	40	35	32	30	28	28	28	28	28	28	28	28	28	28	28	28
2.2	257	236	216	196	178	161	145	130	115	103	91	80	70	61	54	47	42	37	34	31	30	30	30	30	30	30	30	30	30	30	30
2.3	281	258	237	216	197	179	162	146	131	117	104	92	81	72	63	55	49	43	39	36	33	32	32	32	32	32	32	32	32	32	32
2.4	305	281	259	238	217	198	180	163	147	132	118	105	93	83	73	65	57	51	45	41	38	35	34	34	34	34	34	34	34	34	34
2.5	330	306	282	260	239	218	199	181	164	148	133	119	107	95	84	75	66	59	52	47	43	40	37	36	36	36	36	36	36	36	36
2.6	356	331	306	283	261	240	219	200	182	165	149	135	121	108	97	86	76	68	60	54	49	45	42	40	39	39	39	39	39	39	
2.7	383	357	332	307	284	262	241	221	201	184	167	151	136	122	110	98	88	78	70	62	56	51	47	44	42	41	41	41	41	41	
2.8	412	384	358	332	308	285	263	242	222	203	185	168	152	138	124	111	100	89	80	72	64	58	53	49	46	44	43	43	43	43	
2.9	441	412	385	359	333	309	286	264	243	223	204	186	169	154	139	126	113	102	91	82	74	66	60	55	51	48	46	46	46	46	
3.0	471	442	413	386	360	334	310	287	265	244	224	205	188	171	155	141	127	115	103	93	84	76	68	62	57	53	51	49	48	48	

**NOTES**  
 1. All frontslopes are 14 feet. Stake line is 14 feet uphill from completed terrace ridge and will be the centerline of completed channel. c - cut in channel in feet.  
 2. d - depth of water in feet in the completed terrace, measured from the completed channel bottom to the top of the terrace ridge. Terrace ridge is assumed to always be at the design depth level, even when c exceeds d. Cutslope is 6:1.

Exhibit 8-3 Terrace storage table

## 2% LAND SLOPE

Combined Natural and Excavated Storage in Cubic Feet Per Lineal Foot

c d	0.0	0.1	0.2	0.3	0.4	0.5	0.6	0.7	0.8	0.9	1.0	1.1	1.2	1.3	1.4	1.5	1.6	1.7	1.8	1.9	2.0	2.1	2.2	2.3	2.4	2.5	2.6	3.0
0.1	1	1	1	1	1	1	1	1	1	1	1	1	1	1	1	1	1	1	1	1	1	1	1	1	1	1	1	1
0.2	2	2	2	2	2	2	2	2	2	2	2	2	2	2	2	2	2	2	2	2	2	2	2	2	2	2	2	2
0.3	4	3	3	2	2	2	2	2	2	2	2	2	2	2	2	2	2	2	2	2	2	2	2	2	2	2	2	2
0.4	7	5	4	3	3	3	3	3	3	3	3	3	3	3	3	3	3	3	3	3	3	3	3	3	3	3	3	3
0.5	10	8	6	5	4	4	4	4	4	4	4	4	4	4	4	4	4	4	4	4	4	4	4	4	4	4	4	4
0.6	13	11	8	7	6	5	5	5	5	5	5	5	5	5	5	5	5	5	5	5	5	5	5	5	5	5	5	5
0.7	17	14	11	9	8	7	6	6	6	6	6	6	6	6	6	6	6	6	6	6	6	6	6	6	6	6	6	6
0.8	22	18	15	12	10	9	8	8	8	8	8	8	8	8	8	8	8	8	8	8	8	8	8	8	8	8	8	8
0.9	27	22	19	16	13	11	10	9	9	9	9	9	9	9	9	9	9	9	9	9	9	9	9	9	9	9	9	9
1.0	32	27	23	20	17	14	12	11	10	10	10	10	10	10	10	10	10	10	10	10	10	10	10	10	10	10	10	10
1.1	38	33	28	24	21	18	15	13	12	12	11	11	11	11	11	11	11	11	11	11	11	11	11	11	11	11	11	11
1.2	44	39	34	29	25	22	19	16	15	13	13	13	13	13	13	13	13	13	13	13	13	13	13	13	13	13	13	13
1.3	51	45	40	34	30	26	23	20	18	16	15	14	14	14	14	14	14	14	14	14	14	14	14	14	14	14	14	14
1.4	59	52	46	40	35	31	27	24	21	19	17	16	16	16	16	16	16	16	16	16	16	16	16	16	16	16	16	16
1.5	67	60	53	47	41	36	32	28	25	22	20	19	18	17	17	17	17	17	17	17	17	17	17	17	17	17	17	17
1.6	75	68	60	54	48	42	37	33	29	26	24	22	20	19	19	19	19	19	19	19	19	19	19	19	19	19	19	19
1.7	84	76	68	61	55	49	43	39	34	31	28	25	23	22	21	21	21	21	21	21	21	21	21	21	21	21	21	21
1.8	94	85	77	69	62	56	50	45	40	36	32	29	27	25	23	23	22	22	22	22	22	22	22	22	22	22	22	22
1.9	104	94	86	78	70	63	57	51	46	41	37	33	31	28	26	25	24	24	24	24	24	24	24	24	24	24	24	24
2.0	114	104	95	87	79	71	64	58	52	47	42	38	35	32	30	28	27	26	26	26	26	26	26	26	26	26	26	26
2.1	125	115	105	96	88	80	72	65	59	54	48	44	40	37	34	31	30	29	28	28	28	28	28	28	28	28	28	28
2.2	136	126	116	106	97	89	81	73	67	60	55	50	45	41	38	35	33	32	30	30	30	30	30	30	30	30	30	30
2.3	148	137	127	116	107	98	90	82	75	68	62	56	51	47	43	40	37	35	33	32	32	32	32	32	32	32	32	32
2.4	161	149	138	127	117	108	99	91	83	76	69	63	58	53	49	45	42	39	37	35	34	34	34	34	34	34	34	34
2.5	174	162	150	139	128	118	109	100	92	84	77	71	65	59	54	50	47	43	41	39	37	37	36	36	36	36	36	36
2.6	187	175	162	151	140	129	119	110	101	93	86	79	72	66	61	56	52	48	45	43	41	40	39	39	39	39	39	39
2.7	201	188	175	163	152	141	130	121	111	103	95	87	80	74	68	63	58	54	50	47	45	43	42	41	41	41	41	41
2.8	216	202	189	176	164	153	142	132	122	113	104	96	89	82	75	70	64	60	56	52	49	47	45	44	43	43	43	43
2.9	231	216	203	190	177	165	154	143	133	123	114	105	98	90	83	77	71	66	62	58	54	51	49	47	46	46	46	46
3.0	246	231	217	204	191	178	166	155	144	134	124	115	107	99	92	85	79	73	68	64	60	56	54	51	50	49	48	48

### NOTES

1. All frontslopes are 14 feet. Stakeline is 14 feet uphill from completed terrace ridge and will be the centerline of completed channel. c - cut in channel in feet.
2. d - depth of water in feet in the completed terrace, measured from completed channel bottom to the top of the terrace ridge. Terrace ridge is assumed to always be at the design depth level, even when c exceeds d. Cutslope is 6:1.

## 3% LAND SLOPE

## Combined Natural and Excavated Storage in Cubic Feet Per Lineal Foot

<sup>c</sup> d	0.0	0.1	0.2	0.3	0.4	0.5	0.6	0.7	0.8	0.9	1.0	1.1	1.2	1.3	1.4	1.5	1.6	1.7	1.8	1.9	2.0	2.1	2.2	2.3	2.4	3.0
0.1	1	1	1	1	1	1	1	1	1	1	1	1	1	1	1	1	1	1	1	1	1	1	1	1	1	1
0.2	2	2	2	2	2	2	2	2	2	2	2	2	2	2	2	2	2	2	2	2	2	2	2	2	2	2
0.3	4	3	2	2	2	2	2	2	2	2	2	2	2	2	2	2	2	2	2	2	2	2	2	2	2	2
0.4	6	4	4	3	3	3	3	3	3	3	3	3	3	3	3	3	3	3	3	3	3	3	3	3	3	3
0.5	8	6	5	5	4	4	4	4	4	4	4	4	4	4	4	4	4	4	4	4	4	4	4	4	4	4
0.6	10	8	7	6	6	5	5	5	5	5	5	5	5	5	5	5	5	5	5	5	5	5	5	5	5	5
0.7	13	11	9	8	7	7	6	6	6	6	6	6	6	6	6	6	6	6	6	6	6	6	6	6	6	6
0.8	16	14	12	10	9	8	8	8	8	8	8	8	8	8	8	8	8	8	8	8	8	8	8	8	8	8
0.9	20	17	15	13	11	10	9	9	9	9	9	9	9	9	9	9	9	9	9	9	9	9	9	9	9	9
1.0	24	21	18	16	14	12	11	10	10	10	10	10	10	10	10	10	10	10	10	10	10	10	10	10	10	10
1.1	28	24	21	19	17	15	13	12	12	11	11	11	11	11	11	11	11	11	11	11	11	11	11	11	11	11
1.2	32	29	25	22	20	18	16	14	13	13	13	13	13	13	13	13	13	13	13	13	13	13	13	13	13	13
1.3	37	33	29	26	23	21	19	17	16	15	14	14	14	14	14	14	14	14	14	14	14	14	14	14	14	14
1.4	43	38	34	30	27	24	22	20	18	17	16	16	16	16	16	16	16	16	16	16	16	16	16	16	16	16
1.5	48	43	39	35	31	28	25	23	21	20	18	18	17	17	17	17	17	17	17	17	17	17	17	17	17	17
1.6	54	49	44	40	36	32	29	27	24	22	21	20	19	19	19	19	19	19	19	19	19	19	19	19	19	19
1.7	60	55	50	45	41	37	33	30	28	26	24	22	21	21	21	21	21	21	21	21	21	21	21	21	21	21
1.8	67	61	55	50	46	42	38	35	32	29	27	25	24	23	22	22	22	22	22	22	22	22	22	22	22	22
1.9	74	67	62	56	51	47	43	39	36	33	31	28	27	26	25	24	24	24	24	24	24	24	24	24	24	24
2.0	81	74	68	63	57	52	48	44	40	37	34	32	30	28	27	26	26	26	26	26	26	26	26	26	26	26
2.1	88	81	75	69	64	58	54	49	45	42	39	36	34	32	30	29	28	28	28	28	28	28	28	28	28	28
2.2	96	89	82	76	70	65	59	55	50	47	43	40	37	35	33	32	31	30	30	30	30	30	30	30	30	30
2.3	104	97	90	83	77	71	66	61	56	52	48	45	42	39	37	35	34	33	32	32	32	32	32	32	32	32
2.4	113	105	98	91	84	78	72	67	62	57	53	49	46	43	41	39	37	36	35	34	34	34	34	34	34	34
2.5	122	114	106	99	92	85	79	73	68	63	59	55	51	48	45	42	40	39	38	37	36	36	36	36	36	36
2.6	131	122	114	107	100	93	86	80	75	69	65	60	56	53	49	47	44	42	41	40	39	39	39	39	39	39
2.7	140	132	123	115	108	101	94	87	81	76	71	66	62	58	54	51	48	46	44	43	42	41	41	41	41	41
2.8	150	141	132	124	116	109	102	95	89	83	77	72	68	63	59	56	53	50	48	46	45	44	43	43	43	43
2.9	161	151	142	133	125	117	110	103	96	90	84	79	74	69	65	61	58	55	52	50	48	47	46	46	46	46
3.0	171	161	152	143	134	126	118	111	104	98	91	86	80	75	71	67	63	60	57	54	52	51	49	49	48	48

**NOTES**

1. All front slopes are 14 feet. Stake line is 14 feet uphill from completed terrace ridge and will be the centerline of completed channel. c - cut in channel in feet.

2. d - depth of water in feet in completed terrace, measured from completed channel bottom to the top of the terrace ridge. Terrace ridge is assumed to always be at the design depth level, even when c exceeds d. Cutslope is 6:1.

## 4% LAND SLOPE

Combined Natural and Excavated Storage in Cubic Feet Per Lineal Foot

c	0.0	0.1	0.2	0.3	0.4	0.5	0.6	0.7	0.8	0.9	1.0	1.1	1.2	1.3	1.4	1.5	1.6	1.7	1.8	1.9	2.0	2.1	2.2	3.0
0.1	1	1	1	1	1	1	1	1	1	1	1	1	1	1	1	1	1	1	1	1	1	1	1	1
0.2	2	2	2	2	2	2	2	2	2	2	2	2	2	2	2	2	2	2	2	2	2	2	2	2
0.3	3	3	2	2	2	2	2	2	2	2	2	2	2	2	2	2	2	2	2	2	2	2	2	2
0.4	5	4	4	3	3	3	3	3	3	3	3	3	3	3	3	3	3	3	3	3	3	3	3	3
0.5	7	6	5	4	4	4	4	4	4	4	4	4	4	4	4	4	4	4	4	4	4	4	4	4
0.6	9	7	6	6	5	5	5	5	5	5	5	5	5	5	5	5	5	5	5	5	5	5	5	5
0.7	11	9	8	7	7	6	6	6	6	6	6	6	6	6	6	6	6	6	6	6	6	6	6	6
0.8	14	12	10	9	8	8	8	8	8	8	8	8	8	8	8	8	8	8	8	8	8	8	8	8
0.9	16	14	13	11	10	9	9	9	9	9	9	9	9	9	9	9	9	9	9	9	9	9	9	9
1.0	20	17	15	14	12	11	10	10	10	10	10	10	10	10	10	10	10	10	10	10	10	10	10	10
1.1	23	20	18	16	15	13	12	12	11	11	11	11	11	11	11	11	11	11	11	11	11	11	11	11
1.2	26	24	21	19	17	16	14	14	13	13	13	13	13	13	13	13	13	13	13	13	13	13	13	13
1.3	30	27	24	22	20	18	17	16	15	14	14	14	14	14	14	14	14	14	14	14	14	14	14	14
1.4	34	31	28	25	23	21	19	18	17	16	16	16	16	16	16	16	16	16	16	16	16	16	16	16
1.5	39	35	32	29	26	24	22	20	19	18	18	17	17	17	17	17	17	17	17	17	17	17	17	17
1.6	43	39	36	33	30	27	25	23	22	21	20	19	19	19	19	19	19	19	19	19	19	19	19	19
1.7	48	44	40	37	34	31	28	26	25	23	22	21	21	21	21	21	21	21	21	21	21	21	21	21
1.8	53	49	45	41	38	35	32	30	28	26	25	24	23	22	22	22	22	22	22	22	22	22	22	22
1.9	58	54	50	46	42	39	36	33	31	29	27	26	25	25	24	24	24	24	24	24	24	24	24	24
2.0	64	59	55	51	47	43	40	37	35	32	30	29	28	27	26	26	26	26	26	26	26	26	26	26
2.1	70	65	60	56	52	48	44	41	38	36	34	32	31	29	28	28	28	28	28	28	28	28	28	28
2.2	76	71	66	61	57	53	49	46	42	40	37	35	34	32	31	30	30	30	30	30	30	30	30	30
2.3	82	77	71	67	62	58	54	50	47	44	41	39	37	35	34	33	32	32	32	32	32	32	32	32
2.4	89	83	78	72	67	63	59	55	51	48	45	43	41	39	37	36	35	34	34	34	34	34	34	34
2.5	96	90	84	78	73	69	64	60	56	53	50	47	44	42	40	39	38	37	36	36	36	36	36	36
2.6	103	96	90	85	79	74	70	65	61	58	54	51	48	46	44	42	41	40	39	39	39	39	39	39
2.7	110	103	97	91	86	80	75	71	67	63	59	56	53	50	48	46	44	43	42	41	41	41	41	41
2.8	118	111	104	98	92	87	82	77	72	68	64	61	57	54	52	50	48	46	45	44	43	43	43	43
2.9	125	118	112	105	99	93	88	83	78	74	69	66	62	59	56	54	52	50	48	47	46	46	46	46
3.0	134	126	119	113	106	100	94	89	84	79	75	71	67	64	61	58	56	54	52	50	49	49	48	48

NOTES

1. All front slopes are 14 feet. Stake line is 14 feet uphill from completed terrace ridge and will be the centerline of completed channel. c - cut in channel in feet.
2. d - depth of water in feet in completed terrace, measured from completed channel bottom to top of terrace ridge. Terrace ridge is assumed to always be at the design depth level, even when c exceeds d. Cutslope is 6:1.

## 5% LAND SLOPE

Combined Natural and Excavated Storage in Cubic Feet Per Lineal Foot

c \ d	0.0	0.1	0.2	0.3	0.4	0.5	0.6	0.7	0.8	0.9	1.0	1.1	1.2	1.3	1.4	1.5	1.6	1.7	1.8	1.9	2.0	3.0
0.1	1	1	1	1	1	1	1	1	1	1	1	1	1	1	1	1	1	1	1	1	1	1
0.2	2	2	2	2	2	2	2	2	2	2	2	2	2	2	2	2	2	2	2	2	2	2
0.3	3	3	2	2	2	2	2	2	2	2	2	2	2	2	2	2	2	2	2	2	2	2
0.4	4	4	3	3	3	3	3	3	3	3	3	3	3	3	3	3	3	3	3	3	3	3
0.5	6	5	5	4	4	4	4	4	4	4	4	4	4	4	4	4	4	4	4	4	4	4
0.6	8	7	6	6	5	5	5	5	5	5	5	5	5	5	5	5	5	5	5	5	5	5
0.7	10	9	8	7	7	6	6	6	6	6	6	6	6	6	6	6	6	6	6	6	6	6
0.8	12	11	9	9	8	8	8	8	8	8	8	8	8	8	8	8	8	8	8	8	8	8
0.9	14	13	11	10	10	9	9	9	9	9	9	9	9	9	9	9	9	9	9	9	9	9
1.0	17	15	14	12	11	11	10	10	10	10	10	10	10	10	10	10	10	10	10	10	10	10
1.1	20	18	16	15	13	12	12	11	11	11	11	11	11	11	11	11	11	11	11	11	11	11
1.2	23	21	19	17	16	14	14	13	13	13	13	13	13	13	13	13	13	13	13	13	13	13
1.3	26	24	21	20	18	17	16	15	14	14	14	14	14	14	14	14	14	14	14	14	14	14
1.4	29	27	24	22	21	19	18	17	16	16	16	16	16	16	16	16	16	16	16	16	16	16
1.5	33	30	28	25	23	22	20	19	18	18	17	17	17	17	17	17	17	17	17	17	17	17
1.6	37	34	31	29	26	24	23	21	20	20	19	19	19	19	19	19	19	19	19	19	19	19
1.7	41	38	35	32	30	27	26	24	23	22	21	21	21	21	21	21	21	21	21	21	21	21
1.8	45	42	38	36	33	31	29	27	25	24	23	23	22	22	22	22	22	22	22	22	22	22
1.9	49	46	42	39	37	34	32	30	28	27	26	25	24	24	24	24	24	24	24	24	24	24
2.0	54	50	47	43	40	38	35	33	31	30	28	27	27	26	26	26	26	26	26	26	26	26
2.1	59	55	51	48	44	41	39	36	34	33	31	30	29	28	28	28	28	28	28	28	28	28
2.2	64	60	56	52	49	45	43	40	38	36	34	33	32	31	30	30	30	30	30	30	30	30
2.3	69	65	60	57	53	50	47	44	41	39	37	36	34	33	33	32	32	32	32	32	32	32
2.4	74	70	65	61	58	54	51	48	45	43	41	39	37	36	35	35	34	34	34	34	34	34
2.5	80	75	71	66	62	59	55	52	49	47	44	42	41	39	38	37	37	36	36	36	36	36
2.6	86	81	76	72	67	63	60	56	53	51	48	46	44	42	41	40	39	39	39	39	39	39
2.7	92	87	82	77	73	68	65	61	58	55	52	50	48	46	44	43	42	41	41	41	41	41
2.8	98	93	87	83	78	74	70	66	62	59	56	54	51	49	48	46	45	44	44	43	43	43
2.9	104	99	93	88	84	79	75	71	67	64	61	58	55	53	51	50	48	47	46	46	46	46
3.0	111	105	100	94	89	85	80	76	72	69	65	62	60	57	55	53	52	50	49	49	48	48

## NOTES

1. All front slopes are 14 feet. Stake line is 14 feet uphill from completed terrace ridge and will be the centerline of completed channel. c - cut in channel in feet.

2. d - depth of water in feet in completed terrace, measured from completed channel bottom to top of terrace ridge. Terrace ridge is assumed to always be at the design depth level, even when c exceeds d. Cutslope is 6:1.

## 6% LAND SLOPE

## Combined Natural and Excavated Storage in Cubic Feet Per Lineal Foot

c d	0:0	0.1	0.2	0.3	0.4	0.5	0.6	0.7	0.8	0.9	1.0	1.1	1.2	1.3	1.4	1.5	1.6	1.7	1.8	1.9	3.0	
0.1	1	1	1	1	1	1	1	1	1	1	1	1	1	1	1	1	1	1	1	1	1	1
0.2	2	2	2	2	2	2	2	2	2	2	2	2	2	2	2	2	2	2	2	2	2	2
0.3	3	3	2	2	2	2	2	2	2	2	2	2	2	2	2	2	2	2	2	2	2	2
0.4	4	4	3	3	3	3	3	3	3	3	3	3	3	3	3	3	3	3	3	3	3	3
0.5	6	5	4	4	4	4	4	4	4	4	4	4	4	4	4	4	4	4	4	4	4	4
0.6	7	6	6	5	5	5	5	5	5	5	5	5	5	5	5	5	5	5	5	5	5	5
0.7	9	8	7	7	6	6	6	6	6	6	6	6	6	6	6	6	6	6	6	6	6	6
0.8	11	10	9	8	8	8	8	8	8	8	8	8	8	8	8	8	8	8	8	8	8	8
0.9	13	12	11	10	9	9	9	9	9	9	9	9	9	9	9	9	9	9	9	9	9	9
1.0	15	14	13	12	11	10	10	10	10	10	10	10	10	10	10	10	10	10	10	10	10	10
1.1	18	16	15	14	13	12	12	11	11	11	11	11	11	11	11	11	11	11	11	11	11	11
1.2	20	19	17	16	15	14	13	13	13	13	13	13	13	13	13	13	13	13	13	13	13	13
1.3	23	21	19	18	17	16	15	14	14	14	14	14	14	14	14	14	14	14	14	14	14	14
1.4	26	24	22	20	19	18	17	16	16	16	16	16	16	16	16	16	16	16	16	16	16	16
1.5	29	27	25	23	21	20	19	18	18	17	17	17	17	17	17	17	17	17	17	17	17	17
1.6	33	30	28	26	24	23	21	20	20	19	19	19	19	19	19	19	19	19	19	19	19	19
1.7	36	33	31	29	27	25	24	23	22	21	21	21	21	21	21	21	21	21	21	21	21	21
1.8	40	37	34	32	30	28	26	25	24	23	22	22	22	22	22	22	22	22	22	22	22	22
1.9	43	40	38	35	33	31	29	28	26	25	24	24	24	24	24	24	24	24	24	24	24	24
2.0	47	44	41	39	36	34	32	30	29	28	27	26	26	26	26	26	26	26	26	26	26	26
2.1	51	48	45	42	40	37	35	33	32	31	30	29	28	28	28	28	28	28	28	28	28	28
2.2	56	52	49	46	43	41	38	36	35	33	32	31	31	30	30	30	30	30	30	30	30	30
2.3	60	57	53	50	47	44	42	40	38	36	35	34	33	32	32	32	32	32	32	32	32	32
2.4	65	61	57	54	51	48	46	43	41	39	38	37	36	35	34	34	34	34	34	34	34	34
2.5	70	66	62	58	55	52	49	47	45	43	41	40	38	37	37	36	36	36	36	36	36	36
2.6	75	70	66	63	59	56	53	51	48	46	44	43	41	40	39	39	39	39	39	39	39	39
2.7	80	75	71	67	64	60	57	55	52	50	48	46	44	43	42	41	41	41	41	41	41	41
2.8	85	80	76	72	68	65	62	59	56	54	51	49	48	46	45	44	44	44	43	43	43	43
2.9	90	86	81	77	73	70	66	63	60	57	55	53	51	50	48	47	46	46	46	46	46	46
3.0	96	91	87	82	78	74	71	67	64	62	59	57	55	53	52	50	49	49	48	48	48	48

## NOTES

1. All frontslopes are 14 feet. Stakeline is 14 feet uphill from completed terrace ridge and will be the center-line of completed channel. c - cut in channel in feet.

2. d - depth of water in feet in completed terrace, measured from completed channel bottom to top of terrace ridge. Terrace ridge is assumed to always be at the design depth level, even when c exceeds d. Cutslope is 6:1.

## 8% LAND SLOPE

## Combined Natural and Excavated Storage in Cubic Feet Per Lineal Foot

$\frac{c}{d}$	0.0	0.1	0.2	0.3	0.4	0.5	0.6	0.7	0.8	0.9	1.0	1.1	1.2	1.3	1.4	1.5	3.0
0.1	1	1	1	1	1	1	1	1	1	1	1	1	1	1	1	1	1
0.2	2	2	2	2	2	2	2	2	2	2	2	2	2	2	2	2	2
0.3	3	2	2	2	2	2	2	2	2	2	2	2	2	2	2	2	2
0.4	4	3	3	3	3	3	3	3	3	3	3	3	3	3	3	3	3
0.5	5	5	4	4	4	4	4	4	4	4	4	4	4	4	4	4	4
0.6	6	6	5	5	5	5	5	5	5	5	5	5	5	5	5	5	5
0.7	8	7	7	6	6	6	6	6	6	6	6	6	6	6	6	6	6
0.8	10	9	8	8	8	8	8	8	8	8	8	8	8	8	8	8	8
0.9	11	10	10	9	9	9	9	9	9	9	9	9	9	9	9	9	9
1.0	13	12	11	11	10	10	10	10	10	10	10	10	10	10	10	10	10
1.1	15	14	13	12	12	11	11	11	11	11	11	11	11	11	11	11	11
1.2	17	16	15	14	13	13	13	13	13	13	13	13	13	13	13	13	13
1.3	20	18	17	16	15	15	14	14	14	14	14	14	14	14	14	14	14
1.4	22	20	19	18	17	16	16	16	16	16	16	16	16	16	16	16	16
1.5	25	23	21	20	19	18	18	17	17	17	17	17	17	17	17	17	17
1.6	27	25	24	22	21	20	20	19	19	19	19	19	19	19	19	19	19
1.7	30	28	26	25	23	22	22	21	21	21	21	21	21	21	21	21	21
1.8	33	31	29	27	26	25	24	23	23	22	22	22	22	22	22	22	22
1.9	36	34	32	30	28	27	26	25	25	24	24	24	24	24	24	24	24
2.0	39	37	35	33	31	30	28	27	27	26	26	26	26	26	26	26	26
2.1	42	40	38	36	34	32	31	30	29	28	28	28	28	28	28	28	28
2.2	46	43	41	39	37	35	34	32	31	31	30	30	30	30	30	30	30
2.3	49	46	44	42	40	38	36	35	34	33	32	32	32	32	32	32	32
2.4	53	50	47	45	43	41	39	38	37	36	35	34	34	34	34	34	34
2.5	57	54	51	48	46	44	42	41	39	38	37	37	36	36	36	36	36
2.6	60	57	54	52	49	47	45	44	42	41	40	39	39	39	39	39	39
2.7	65	61	58	55	53	51	49	47	45	44	43	42	41	41	41	41	41
2.8	69	65	62	59	57	54	52	50	48	47	46	45	44	43	43	43	43
2.9	73	69	66	63	60	58	55	53	52	50	49	48	47	46	46	46	46
3.0	77	74	70	67	64	62	59	57	55	53	52	51	50	49	48	48	48

**NOTES**

1. All frontslopes are 14 feet. Stake line is 14 feet uphill from completed terrace ridge and will be the centerline of completed channel.  $c$  - cut in channel in feet.
2.  $d$  - depth of water in feet in completed terrace, measured from completed channel bottom to top of terrace ridge. Terrace ridge is assumed to always be at the design depth level, even when  $c$  exceeds  $d$ . Cut slope is 6:

## 10% LAND SLOPE

### Combined Natural and Excavated Storage in Cubic Feet Per Lineal Foot

c d	0.0	0.1	0.2	0.3	0.4	0.5	0.6	0.7	0.8	0.9	1.0	1.1	1.2	3.0
0.1	1	1	1	1	1	1	1	1	1	1	1	1	1	1
0.2	2	2	2	2	2	2	2	2	2	2	2	2	2	2
0.3	3	2	2	2	2	2	2	2	2	2	2	2	2	2
0.4	4	3	3	3	3	3	3	3	3	3	3	3	3	3
0.5	5	4	4	4	4	4	4	4	4	4	4	4	4	4
0.6	6	6	5	5	5	5	5	5	5	5	5	5	5	5
0.7	7	7	7	6	6	6	6	6	6	6	6	6	6	6
0.8	9	8	8	8	8	8	8	8	8	8	8	8	8	8
0.9	10	10	9	9	9	9	9	9	9	9	9	9	9	9
1.0	12	11	11	10	10	10	10	10	10	10	10	10	10	10
1.1	14	13	12	12	11	11	11	11	11	11	11	11	11	11
1.2	16	15	14	13	13	13	13	13	13	13	13	13	13	13
1.3	18	16	16	15	14	14	14	14	14	14	14	14	14	14
1.4	20	18	17	17	16	16	16	16	16	16	16	16	16	16
1.5	22	20	19	18	18	17	17	17	17	17	17	17	17	17
1.6	24	23	21	20	20	19	19	19	19	19	19	19	19	19
1.7	26	25	24	22	22	21	21	21	21	21	21	21	21	21
1.8	29	27	26	25	24	23	23	22	22	22	22	22	22	22
1.9	31	30	28	27	26	25	25	24	24	24	24	24	24	24
2.0	34	32	31	29	28	27	27	26	26	26	26	26	26	26
2.1	37	35	33	32	30	29	29	28	28	28	28	28	28	28
2.2	40	38	36	34	33	32	31	30	30	30	30	30	30	30
2.3	43	40	39	37	35	34	33	33	32	32	32	32	32	32
2.4	46	43	41	40	38	37	36	35	34	34	34	34	34	34
2.5	49	46	44	42	41	39	38	37	37	36	36	36	36	36
2.6	52	50	47	45	44	42	41	40	39	39	39	39	39	39
2.7	55	53	51	48	47	45	44	43	42	41	41	41	41	41
2.8	59	56	54	52	50	48	47	45	44	44	43	43	43	43
2.9	62	60	57	55	53	51	50	48	47	46	46	46	46	46
3.0	66	63	61	58	56	54	53	51	50	49	49	48	48	48

#### NOTES

1. All frontslopes are 14 feet. Stake line is 14 feet uphill from completed terrace ridge and will be the centerline of completed channel. c - cut in channel in feet.
2. d - depth of water in feet in completed terrace, measured from completed channel bottom to top of terrace ridge. Terrace ridge is assumed to always be at the design depth level, even when c exceeds d. Cutslope is 6:1

Acres Drained by Various Sizes of Tile

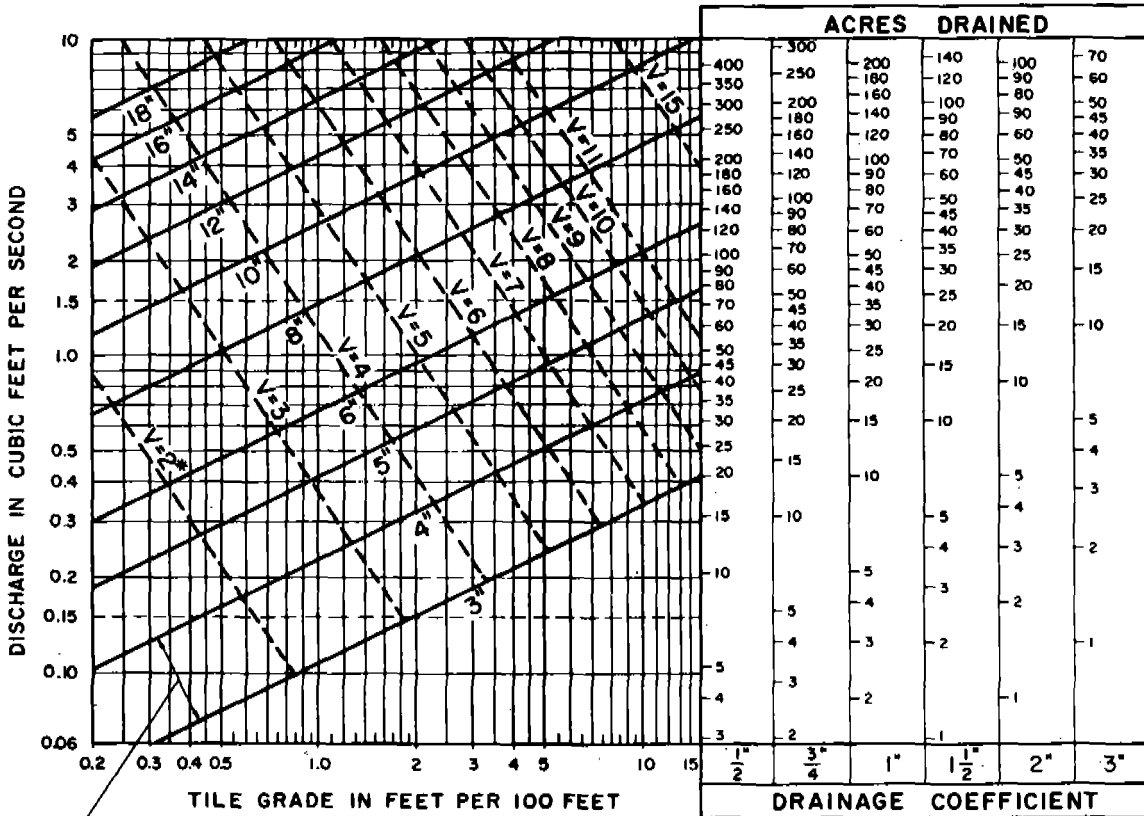

Space between lines is the range of tile capacity for the size shown between lines

Reference: Yarnell-Woodward Formula  $v = 138 r^{2/3} s^{1/2}$  U.S.D.A. Bulletin 854

\* V equals velocity in feet per second

**DESIGN DATA**  
**UNDERGROUND OUTLETS**  
**FOR GRADED TERRACES**

U. S. DEPARTMENT OF AGRICULTURE  
 SOIL CONSERVATION SERVICE

Compiled	Checked	Date	Drawing No.
		12 - 65	5,0-22,438

Riser Size		Orifice Diameter		Head - (feet)											
Above Orifice	Below Orifice	Inches	Sq.Ft.	1.0	1.5	2.0	2.5	3.0	3.5	4.0	4.5	5.0	5.5	6.0	
6" C.M. Pipe	4" Sewer Pipe	1.00	.006	.027	.033	.038	.042	.046	.050	.053	.056	.059	.062	.065	
		1.25	.009	.042	.051	.059	.066	.072	.078	.083	.088	.093	.097	.102	
		1.50	.012	.059	.073	.084	.094	.103	.111	.119	.126	.133	.139	.146	
		1.75	.017	.081	.099	.114	.128	.140	.151	.162	.172	.181	.190	.198	
		2.00	.022	.105	.129	.149	.166	.182	.197	.210	.223	.235	.247	.258	
		2.25	.028	.133	.163	.188	.210	.231	.249	.266	.282	.298	.312	.326	
		2.50	.034	.164	.201	.232	.259	.284	.307	.328	.348	.367	.385	.402	
		2.75	.041	.199	.243	.281	.314	.344	.371	.397	.421	.444	.466	.486	
		3.00	.049	.236	.289	.333	.373	.408	.441	.472	.500	.527	.553	.578	
		3.25	.058	.277	.339	.391	.438	.479	.518	.554	.587	.619	.649	.678	
		3.50	.067	.321	.393	.454	.508	.556	.600	.642	.681	.718	.753	.786	
8" C.M. Pipe	6" Sewer Pipe	3.75	.077	.369	.451	.521	.583	.638	.689	.737	.782	.824	.864	.903	
		4.00	.087	.419	.513	.592	.662	.725	.783	.837	.888	.936	.982	1.03	
		4.25	.099	.473	.579	.668	.747	.818	.884	.945	1.00	1.06	1.11	1.16	
		4.50	.110	.530	.649	.749	.838	.917	.991	1.06	1.12	1.18	1.24	1.30	
		4.75	.123	.590	.723	.835	.933	1.02	1.10	1.18	1.25	1.32	1.38	1.45	
		5.00	.136	.654	.801	.925	1.03	1.13	1.22	1.31	1.39	1.46	1.53	1.60	
		5.25	.150	.721	.883	1.02	1.14	1.24	1.35	1.44	1.53	1.61	1.69	1.77	
10" C.M. Pipe	8" Sewer Pipe	5.50	.165	.790	.968	1.12	1.25	1.37	1.48	1.58	1.68	1.77	1.85	1.94	
		5.75	.180	.863	1.06	1.22	1.37	1.50	1.62	1.72	1.83	1.93	2.02	2.11	
		6.00	.196	.940	1.15	1.33	1.49	1.63	1.76	1.88	1.99	2.10	2.20	2.30	

Exhibit 8-5 Discharge rates of circular orifice in c.f.s.

USE THIS SCALE FOR SINGLE LINES OF RANDOM OR INTERCEPTOR DRAINS AND MAINS

DISCHARGE IN CUBIC FEET PER SECOND

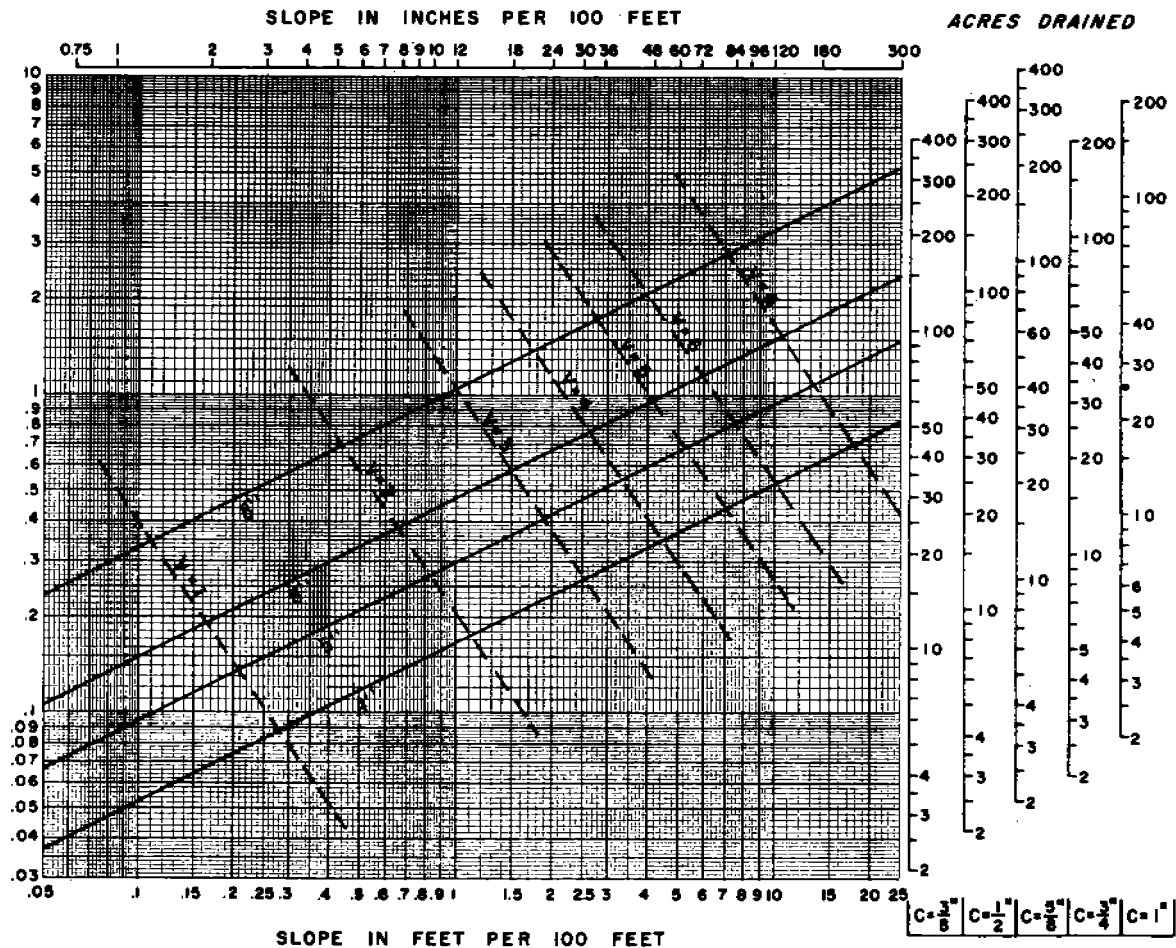

USE THESE SCALES ON PATTERN OR SYSTEMATIC DRAINAGE

DRAINAGE COEFFICIENT - C

REFERENCE  
 DISCHARGE BASED ON:  
 $v = 99R^{2/3} S^{1/2}$   
 PIPE FLOWING FULL, MANNING N=0.015

U. S. DEPARTMENT OF AGRICULTURE  
 SOIL CONSERVATION SERVICE  
 ENGINEERING & WATERSHED PLANNING UNIT  
 UPPER DARBY, PENNSYLVANIA

RTSC - NE - ENG.  
 1442  
 SHEET 1 OF 1

EXHIBIT 8-6 DRAIN CHART - CORRUGATED PLASTIC DRAIN TUBING