



December 30, 1982

ENGINEERING-AGRICULTURAL ENGINEERING NOTE-2, 210-VI

SUBJECT: ENG-AQUACULTURE PUMPING PLANTS

Purpose. To distribute Agricultural Engineering Note 2, "Aquaculture Pumping Plants."

Effective Date. Effective when received.

Background. Agricultural Engineering Note-2 was developed by the National Aquaculture Activity Team (NAAT) to provide guidance and information to the Soil Conservation Service field staffs in the selection and sizing of pumping equipment for aquaculture.

Filing Instructions. Agricultural Engineering Note-2 should be filed with other Agricultural Engineering Notes under Title 210 of the directives system.

PAUL M. HOWARD
Deputy Chief for Technology
Development and Application

Enclosure

DIST: AEN-2





11



AQUACULTURE PUMPING PLANTS

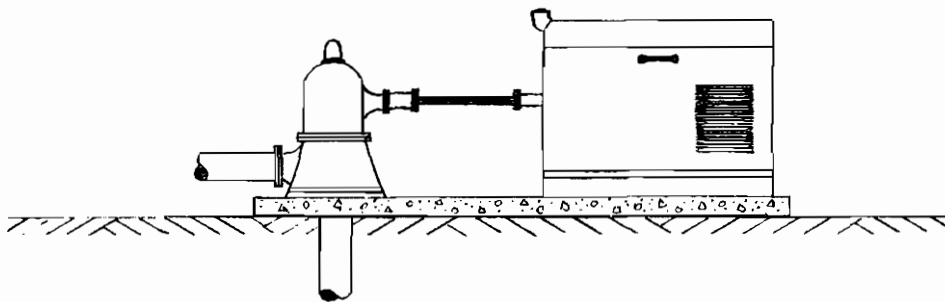



..



PREFACE

Soil Conservation Service is involved in aquaculture by providing technical assistance in resource assessment, planning, design, and installation of ponds, raceways, and other facilities for efficient use of soil and water resources. This can include recommendations for the capacity of pumping plants to match the production unit.

Pumping plants are used extensively in aquaculture to fill ponds initially before stocking, to refill ponds quickly after draining for harvest, to provide water exchange to improve quality, and to offset water losses due to seepage and evaporation. A large share of the water pumped into aquaculture ponds comes from deep wells that tap groundwater. In all areas, there is some competition for groundwater withdrawals. There is much concern over the increased use of water from lakes, streams, rivers, and other surface sources, particularly where downstream needs or prior use commitments are threatened. In all instances, the cost of providing water for any use has advanced considerably due to the higher initial cost of larger equipment to pump from greater depths and the sharp rise in energy cost within the last decade.

The purpose of this Engineering Note is to provide guidance and information to SCS field staffs in the selection and sizing of pumping equipment for aquaculture. It is primarily addressed to those ponds that are completely enclosed by a dam whereby runoff from outside areas are excluded. This then leaves only the direct precipitation over the pond either in the form of rain or snow that needs to be considered. Reference is made to the SCS Engineering Field Manual, Chapter 2, Estimating Runoff, to obtain values for precipitation and to compute runoff volumes where watershed drainage is contributing. Chapter 3, Hydraulics, covers the principal types of structures and conveyance techniques as well as appropriate tables and exhibits to compute the flowage. This Engineering Note covers only the pumping plant and related equipment and does not address other types of water delivery methods.



•
•



TABLE OF CONTENTS

	<u>Page</u>
PREFACE -----	ii
TABLES AND ILLUSTRATIONS -----	iv
AQUACULTURE WATER USE -----	1
General -----	1
Water Quality -----	1
Fish Tolerance -----	1
WATER VOLUMES -----	2
Water Transfer -----	2
Reservoir Filling -----	2
Stable Water Level -----	3
Maintain Water Quality -----	3
PUMPS -----	5
Pump Selection -----	5
Centrifugal Pumps -----	7
Jet Pumps -----	7
Deep Well Turbine Pumps -----	7
Submersible Pumps -----	7
Propeller Pumps -----	8
Data for Selecting Pump -----	9
Suction Lift -----	9
Discharge Head -----	10
Total Dynamic Head -----	10
Pump Design -----	11
WELLS -----	13
Well Design -----	13
Well Size and Capacity -----	13
Well Installation -----	14
POWER UNITS -----	15
Electric Motors -----	15
Internal Combustion Engines -----	16
Pump Drives -----	16
Drive Speed -----	17
Power Requirements -----	17
Fuel Cost -----	18
STEP-BY-STEP PROCEDURE FOR DESIGN OF A PUMPING PLANT -----	23
MAINTENANCE -----	25
REFERENCES -----	25

TABLES AND ILLUSTRATIONS

<u>Table</u>		<u>Page</u>
1	FLOW RATES (GPM) EQUIVALENT TO AC-FT. PER DAY AND LITERS PER SECOND (L/S) -----	3
2	POND FILLING TIME -----	4
3	MAXIMUM DESIGN STATIC SIPHON LIFT -----	10
4	RECOMMENDED WELL DIAMETERS -----	13
5	FLOW OF WATER IN CAST IRON PIPE -----	19
6	FLOW OF WATER IN PLASTIC (PVC) PIPE -----	20
7	FLOW OF WATER IN ASBESTOS CEMENT PRESSURE PIPE -----	20
8	FLOW OF WATER IN WELDED STEEL PIPE 15 YEARS OLD -----	21
9	FLOW OF WATER IN ALUMINUM PIPE -----	21
10	FLOW MEASUREMENT -----	22

<u>Figure</u>		
1	Direct Connected Horizontal Centrifugal Pump -----	5
2	Deep Well Turbine Pump -----	6
3	Propeller Pump -----	8
4	Typical Characteristic Curves for a Vertical Turbine Pump -----	12

AQUACULTURE WATER USE

General

Commercial aquaculture, like other intensive agricultural enterprises, requires large quantities of water. During the decade of the 1970's, the growth of commercial aquaculture in the United States was phenomenal. This has been particularly so in the warm-water aquaculture area centered in the Southcentral United States. Catfish processors handled 27,443 metric tons (60.5 million pounds) in 1981, compared with 1,452 metric tons (3.2 million pounds) in 1969 to illustrate the industry's growth. The rapid growth of commercial aquaculture has caused a large increase in pumping plants to fill ponds, provide aeration by pumping and to offset seepage and evaporation losses.

Water Quality

Water quality is the most important factor in the culture of fish, either cold water or warm water. Low dissolved oxygen is the most critical problem. The atmosphere is a vast reservoir of oxygen, but atmospheric oxygen is only slightly soluble in water. Photosynthesis by phytoplankton within the pond is the primary source of dissolved oxygen in a fish culture system. The primary losses of dissolved oxygen from a pond include respiration by the plankton, fishes, and benthic organisms and diffusion of oxygen into the air. Since photosynthesis occurs only in the presence of light, severe oxygen depletion occurs in the lower depths of ponds and even near the surface if an extended period of cloudy weather occurs. A sudden die-off of algae that associate with heavy plankton blooms will cause a depletion of dissolved oxygen. When dissolved oxygen is low, concentrations of carbon dioxide are usually quite high. This occurs because of the excess respiration rate of the fish, plankton, and benthic organisms.

Water quality may affect selection of screen material, screen design, and casing material used in well installations. Carbonates in the water tend to deposit in screen openings. Water may also have corrosive tendencies and the screen and casing material needs to be selected to prevent this.

Fish Tolerance

Warm water fish grow best at temperatures between 25° and 32°C (77° and 90°F). The optimal or preferred water temperature range for cool water species, particularly the Salmon genus that include rainbow trout, is 10° to 18°C (50° to 64°F). Temperature fluxuations have a pronounced effect on chemical and biological processes occurring in fish culture. Fish have poor tolerances to sudden changes in temperature. Often, a sudden change in temperature of as little as 5°C will stress or even kill fish.

Other factors affecting the culture of fish include the presence of ammonia, hydrogen sulfide, total alkalinity and total hardness, pH, aquatic weeds, and pollutants. These are generally not as severe problems; nevertheless, they can adversely affect fish production.

Aeration and water exchange by pumping are two ways to help rid the water of harmful gases and increase oxygen levels. Well water, however, is often low in oxygen and must be splashed against a hard surface or sprayed into the air before it enters the pond. Water from streams or ponds can be a source of wild fish and disease and parasite contamination.

WATER VOLUMES

Water Transfer

One of the initial steps in planning and designing an aquaculture pumping plant is to determine the total volume of water needed or the required capacity of the pump in terms of volume per unit of time. The capacity or pumping rate for water transfer is usually expressed in liters per second (L/s), or gallons per minute (gpm). In planning the capacity of pumping plants, one should consider the likelihood of expansion within the next few years. Increasing the size of plants including wells may be more cost effective during the initial installation than adding additional units later if expansion is anticipated.

Reservoir Filling

Reservoir filling, occurring just after construction, or refilling after draw-down and fish harvest require the transfer of large volumes of water. One can make a good estimate of the water volume in ponds if the dimensions of the pond area are known. Rectangular ponds with uniform side slopes and bottom surface can be computed by the following method:

$$V = \frac{A_T + A_B}{2} \times d \quad (1)$$

where V = volume in cubic meters or acre-feet

A_T = area of the top or pond surface in square meters or acres

A_B = area of pond bottom or starting level in square meters or acres

d = depth of filling or distance between A_T & A_B in meters or feet depending on units measured

Equation (1) is applicable only when the areas of the top and bottom surface are very near the same. For other cases, the prismoidal formula will apply. Computing water volumes in ponds with irregular widths and depths is more complex and may require field surveys to obtain intermediate areas at several contour levels. Topographic maps from which areas at several elevations can be planimetered and calculated to obtain storage should be used on large complex designs. A fairly reliable rule of thumb to use in the absence of more exact field data is to multiply the surface area of the pond by 0.4 times its depth at the dam:

$$V = A_T \times 0.4d \quad (2)$$

where V = volume in cubic meters or acre-feet

Conversion of volumes and flow rates from the U. S. Customary units to the International System of Units (SI) may be done by utilizing the following expressions:

$$1 \text{ cubic meter (m}^3\text{)} = 1000 \text{ liters} = 264 \text{ gal.} \quad (3)$$

$$1 \text{ Ac-ft (AF)} = 325,880 \text{ gal.} = 1.233 \times 10^6 \text{ liters (L)} \quad (4)$$

$$1 \text{ Ac-ft/day} = 226.3 \text{ gal/min (gpm)} = 14.26 \text{ liters/sec (L/s)} \quad (5)$$

$$1 \text{ cu. ft./sec (cfs)} = 448.8 \text{ gpm} = 28.3 \text{ L/s} = .0283 \text{ m}^3/\text{s} \quad (6)$$

$$1 \text{ liter per second (L/s)} = 15.85 \text{ gallons per minute (gpm)} \quad (7)$$

Table 1. Flow Rates (gpm) Equivalent to Ac-Ft Per Day and Liters Per Second (L/s)

gpm	ac-ft/day	L/s	gpm	ac-ft/day	L/s
50	0.22	3.15	1,000	4.42	63.09
100	0.44	6.31	1,500	6.63	94.64
200	0.88	12.62	2,000	8.84	126.18
300	1.33	18.93	2,500	11.05	157.72
400	1.77	25.24	3,000	13.26	189.27
500	2.21	31.54	4,000	17.68	252.36
750	3.31	47.32	5,000	22.09	315.45

Stable Water Level

Often there is a need to add additional water to ponds to maintain a stable water level. The pumping requirements to offset losses occurring from seepage and evaporation are usually calculated by estimating those losses in terms of acre-inches per day and converting this to gallons per minute or liters per second.

$$1 \text{ Ac-in/day} = 18.86 \text{ gpm} = 1.19 \text{ L/s} \quad (8)$$

Maintaining Water Quality

Circulating and exchanging water in a pond is recognized as a practical method of maintaining water quality particularly in keeping dissolved oxygen and other gases within acceptable limits. Aerating ponds by pumping water from other sources is a common practice in aquaculture. Again, these pumping rates are generally computed by estimating the volume of exchange desired or by calculating the pumping rate needed to raise the oxygen content from one level to another. The latter determination would depend on the oxygen transfer rate of the pump and aerator and is not addressed in this engineering note.

Table 2. Pond Filling Time

Pond Size	Depth = 4' ^{1/}					
	Pumping Rates - gpm					
ac.	200	500	1,000	1,500	2,000	3,000
	-----days-----					
1	4.5	1.8	0.9	0.6	0.5	0.3
2	9	3.6	1.8	1.2	0.9	0.6
5	23	9	4.5	3.0	2.3	1.5
10	45	18	9	6.0	4.5	3
20	90	36	18	12	9	6
40	-	72	36	24	18	12
80	-	-	72	48	36	24

^{1/} Assuming no significant difference between the areas of pond surface and pond bottom or the area 4' below the surface.

Example Problem

Determine the most practical pumping requirements for the following conditions:

- (a) Fill a newly constructed reservoir that is 40 acres in size to a depth of four feet within a time span of four weeks.*
- (b) Expected seepage and evaporation losses of this pond during periods of no precipitation is estimated at 0.5 inches* per acre per day.
- (c) Prevention of oxygen depletion is to be accomplished by pumping at a rate to exchange 4 ac-ft.* of pond volume every day.

* These are assumed values for illustration only. Climatic conditions, site location, and seasonal precipitation must be considered for each situation.

Solution

- (a) Calculated pond volume = 40 x 4 = 160 ac-ft. (assuming no significant difference between top and bottom areas nor seepage and evaporation losses during filling)

$$\text{Pumping rate} = \frac{160 \text{ ac-ft}}{28 \text{ days}} \times 226.3 \text{ (eq. 5)} = 1,293 \text{ gpm}$$

Table 2 indicates a rate more than 1,000 gpm and less than (1,500 gpm)

(b) Pumping rate to offset seepage and evaporation = 0.5 inches per acre per day x 40 acres x 18.86 gpm = 377 gpm

(c) Pumping rate to prevent oxygen depletion = 4 ac-ft. x 226.3 = 905 gpm

Analysis

The pumping requirements are those necessary to fill the pond initially since those necessary for aeration and to offset seepage and evaporation (after filling) are much less. Peak pumping requirements = 1,293 gpm.

PUMPS

Pump Selection

Before a pump can be selected to perform a given job, three operating conditions must be known:

- (1) The desired flow in gallons per minute that the pump must deliver,
- (2) The total discharge head against which it must operate, and
- (3) The suction or pumping lift.

A brief discussion of the types of pumps is given so that one can select the proper type pump for specific locations.

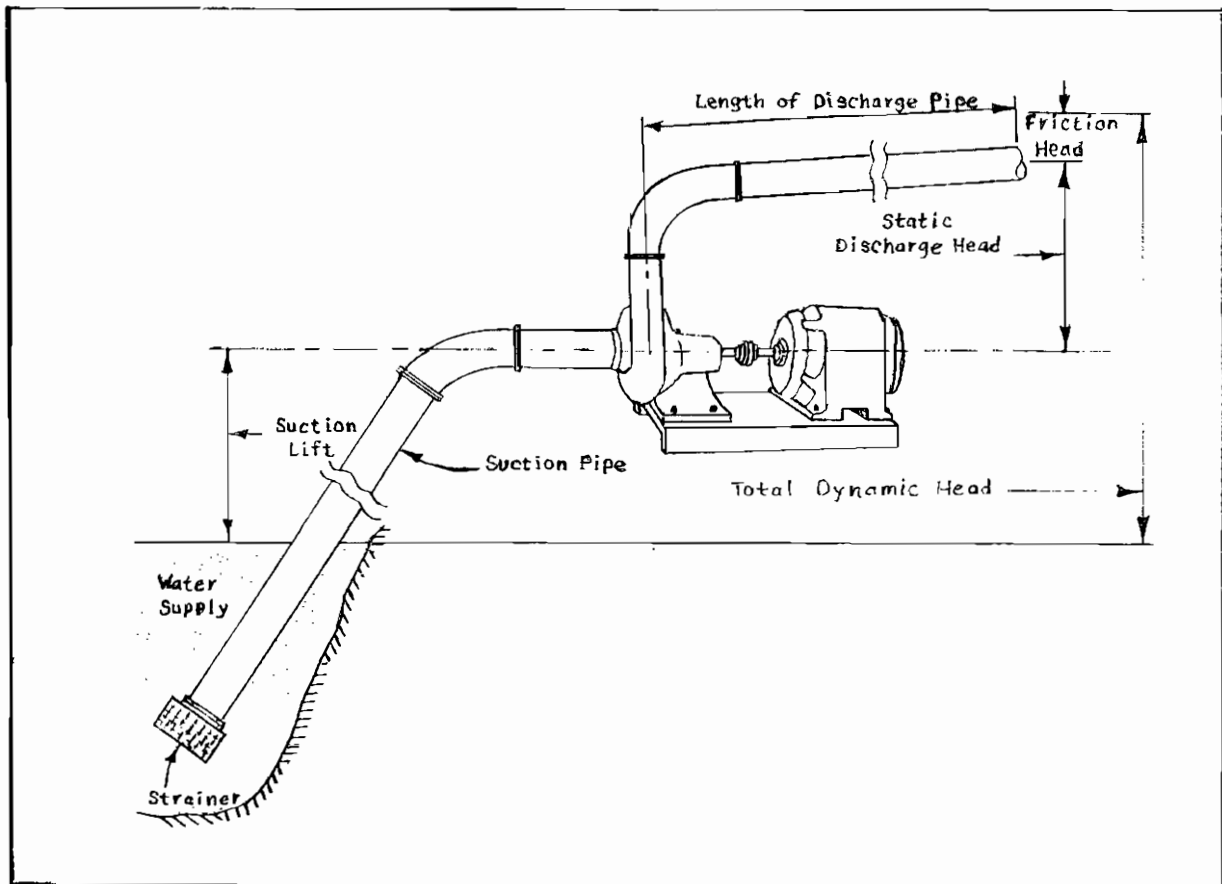

FIGURE 1. DIRECT CONNECTED HORIZONTAL CENTRIFUGAL PUMP

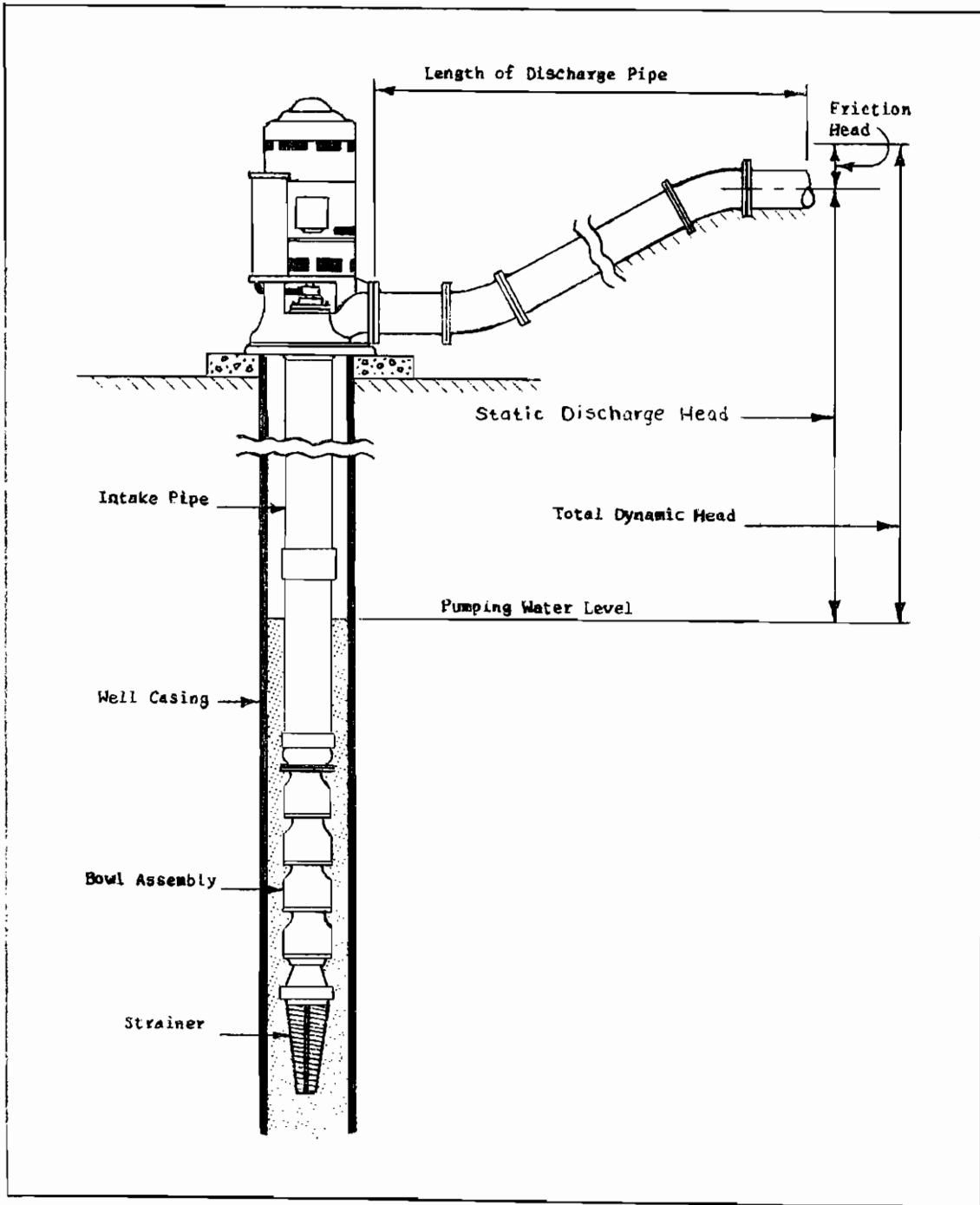

FIGURE 2. DEEP WELL TURBINE PUMP

Centrifugal Pumps

If the source of water is a surface supply such as lakes, streams, ponds, or other body of surface water, the pump most commonly used is the horizontal centrifugal type as shown in Figure 1. These pumps are available as single suction (end suction) and double suction (often called split case). Centrifugal pumps may also be used with shallow wells that do not exceed the allowable suction lift of 5 to 7 meters (17 to 22 feet), outlined in Table 3.

Jet Pumps

For very low capacity requirements (5 to 20 gallons per minute), jet pumps are in common use. These are small centrifugal pumps located at ground level connected to a jet installed below the water level in the well. Shallow well jet pumps are limited to an allowable lift not exceeding approximately 7 meters (22 feet).

Deep Well Turbine Pumps

For a deep well and for capacities above 100 gallons per minute, the most widely used pump is a vertical type centrifugal commonly known as "deep well turbine." Because it can be adapted for almost any head required, the deep well turbine pump is most common for use in wells. They are used in installations where centrifugal pumps cannot be set near the water surface.

The turbine has three main parts: the head, the pump bowl assembly, and the discharge column. A shaft from the head to the pump bowl drives the impellers. The bowl assembly is placed beneath the water surface. It must have a screen to keep coarse sand and gravel from entering the pump. Within each pump bowl is an impeller that discharges directly into another impeller. It is necessary for most applications to stack several bowls or stages in series one above the other. Figure 2 shows a typical turbine pump installation.

Submersible Pumps

The submersible pump consists of a multistage vertical pump connected directly to an electric motor that is designed to operate under water. Both pump and motor are suspended below the water level by means of a pipe which conducts the water to the surface. This type is available in a wide range of capacities for 10.2 centimeter (4-inch) wells and larger. The larger sizes are relatively higher in cost because of the expensive waterproof motor.

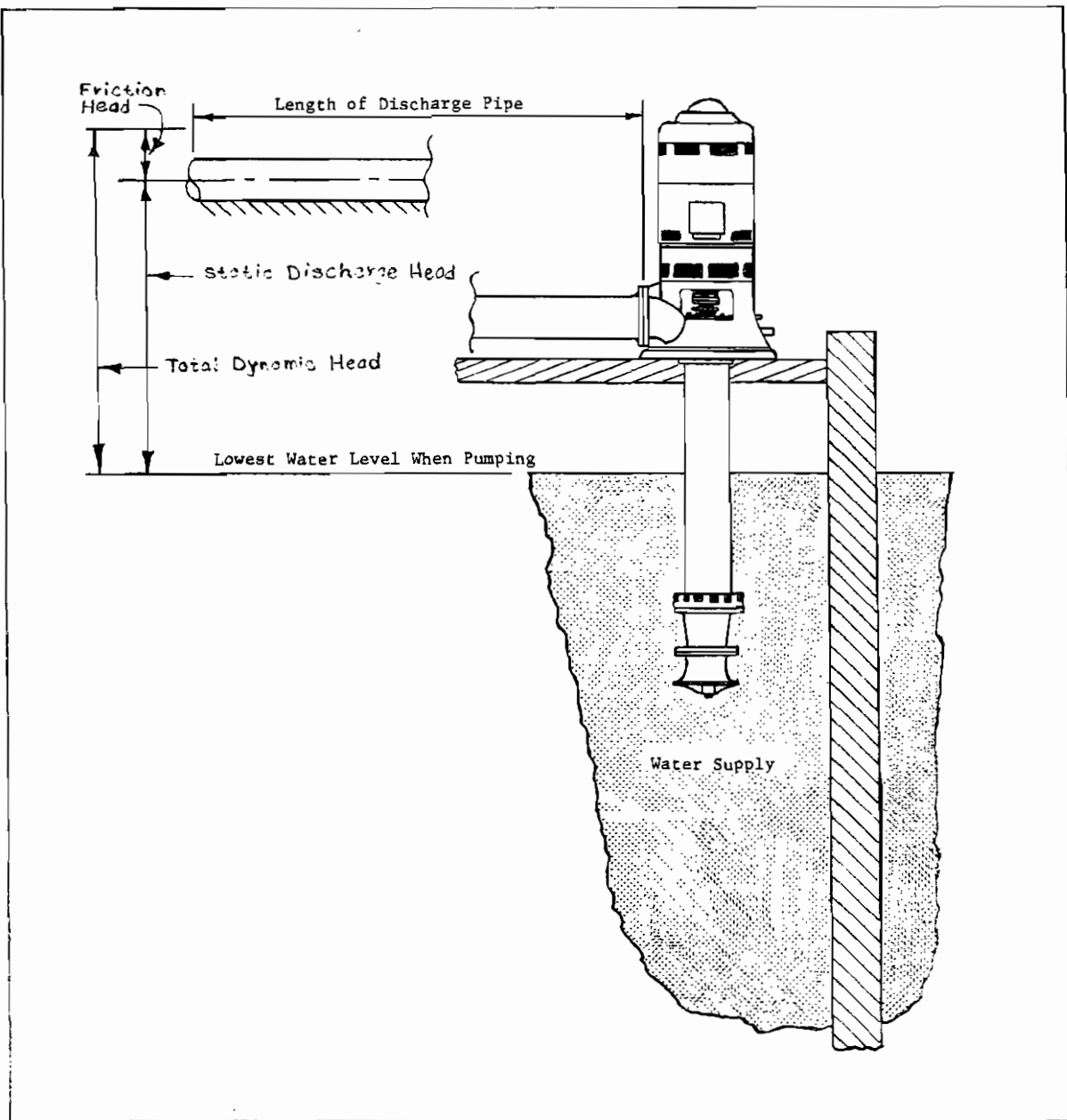

FIGURE 3. PROPELLER PUMP

Propeller Pumps

Propeller pumps, shown in Figure 3, are an efficient means of pumping that are used extensively in drainage installations and for irrigation. They operate at low heads up to 15 meters (50 feet) and at capacities exceeding 500 gallons per minute. Propeller pumps are not suitable for suction lift. The impeller and bowl must be submerged to the proper depth. It is important that proper clearances be maintained between the end of the suction pipe and the side walls and bottom of the pit or pump-intake bay.

Data for Selecting Pump

In order to calculate pump sizes, it is necessary to have as much site-specific operating information as possible. The following items are those most likely needed to make a pump selection:

Source of water supply ----- _____

Vertical lift to pump ----- _____ ft.

Length of suction or lift pipe ----- _____ ft.

Friction loss in required fittings ----- _____ ft.

Elevation lift above pump ----- _____ ft.

Friction head (length of delivery, etc.) ----- _____ ft.

Discharge head (or pressure) required ----- _____ ft.

Total dynamic head ----- _____ ft.

Available power supply:

Electric single phase _____, three phase _____.

Natural gas _____, L. P. Gas _____.

Gasoline _____, Diesel _____.

Suction Lift

Suction lift for centrifugal pumps is composed of the following factors:

- (1) Static suction head (actual vertical distance of center of pump above lowest water surface after pumping begins).
- (2) Friction head in pipelines.
- (3) Head losses in elbows, strainers, foot valves, and other accessories.
- (4) Velocity head.

Atmospheric pressure determines the maximum practical suction lift. This value varies as the altitude, temperature, and local weather conditions change. The highest theoretical suction lift at sea level is 10 meters (34 feet), but this cannot be attained under actual conditions due to friction losses. Pump manufacturers usually recommend that the design suction lift be not more than 70 percent of the theoretical value. They ordinarily list the maximum suction lift of the individual pump which is a function of pump design. Values for maximum design static suction lift based on altitude and water temperature are shown in Table 3.

Table 3. Maximum Design Static Suction Lift
(Approximately 70% of Theoretical)

Altitude ft.	Temperature - °F				
	60°	70°	80°	90°	100°
0	23.4	23.2	23.	22.6	22.2
500	23.	22.8	22.5	22.2	21.8
1,000	22.4	22.3	22.	21.8	21.4
2,000	21.6	21.5	21.2	20.9	20.5
3,000	20.8	20.6	20.4	20.1	19.7
4,000	20.	19.9	19.6	19.3	18.9
5,000	19.2	19.1	18.8	18.6	18.1
6,000	18.5	18.3	18.1	17.8	17.4

Discharge Head

To compute the discharge head, one must combine the several factors that are applicable. These factors or individual heads are described below:

- (1) Static discharge head is the actual vertical distance measured from the centerline of the pump to the centerline of the pipe at the discharge end, or to the surface of the water at the discharge pool, whichever is greater.
- (2) Friction head is that needed to overcome friction in the discharge pipeline including losses in fittings, valves, and other accessories. Head loss coefficients for various pipe materials are presented in Table 5 through Table 9.
- (3) Velocity head at the end of the discharge pipe. Since the velocity of flow will seldom exceed 8 feet per second, the velocity head $\frac{v^2}{2g}$ will seldom exceed 1 foot and, therefore, may be disregarded.
- (4) Pressure head (if applicable) at the end of the discharge pipe.

Total Dynamic Head

The total dynamic head (TDH) for centrifugal pumps is the sum of the total suction lift and the total discharge head less the suction velocity head.

The total dynamic head for deep well turbine pumps differs somewhat from centrifugal pumps in that suction lift is not involved because the impellers of the pump are submerged. Losses in the pump and pump column are included in the

pump efficiency and are not to be considered when computing the total dynamic head. Therefore, the total dynamic head is composed of the following factors:

- (1) Static head which is the actual vertical distance measured from the water level in the well when pumping to the centerline of the pipe at the discharge end.
- (2) Friction head in the discharge pipeline.
- (3) Head losses in elbows, reducers, valves, and other accessories.
- (4) Velocity head at the end of the discharge pipe.
- (5) Pressure required at the end of the discharge pipe.

The total dynamic head for propeller pumps is similar to that for deep well turbine pumps and is composed of the following factors:

- (1) Static head which is the actual vertical distance from the low water level in the pump bay to either; (a) centerline of pipe at the discharge end when the water level is below the pipe outlet; (b) the water level at the discharge end when the outlet is submerged; (c) to the water level in the discharge bay when installation is made to take advantage of siphoning.
- (2) Head losses in pump column that includes a standard length of pipe, pump discharge elbow, and suction bowl. If a longer length of pump column is used than is standard, then additional friction loss must be added.
- (3) Friction head in the discharge pipeline.
- (4) Head losses through valves, strainer, and other fittings.
- (5) Velocity head at the end of the discharge pipe.

The need for intake screens, filters, foot valves, check valves, flow control valves, pressure regulators, and other accessories for protection against unwanted foreign matter and organisms as well as operational monitoring should be considered on a case by case basis.

Examples of typical installations of centrifugal pumps, deep well turbine pumps, and propeller pumps showing major head losses are presented in Figures 1, 2, and 3.

Pump Design

Manufacturers of pumping equipment have developed a series of pumps that have definite characteristics. Their pump bowls are designed to be used either singly or in series to meet any combination of head and discharge with a reasonably high efficiency.

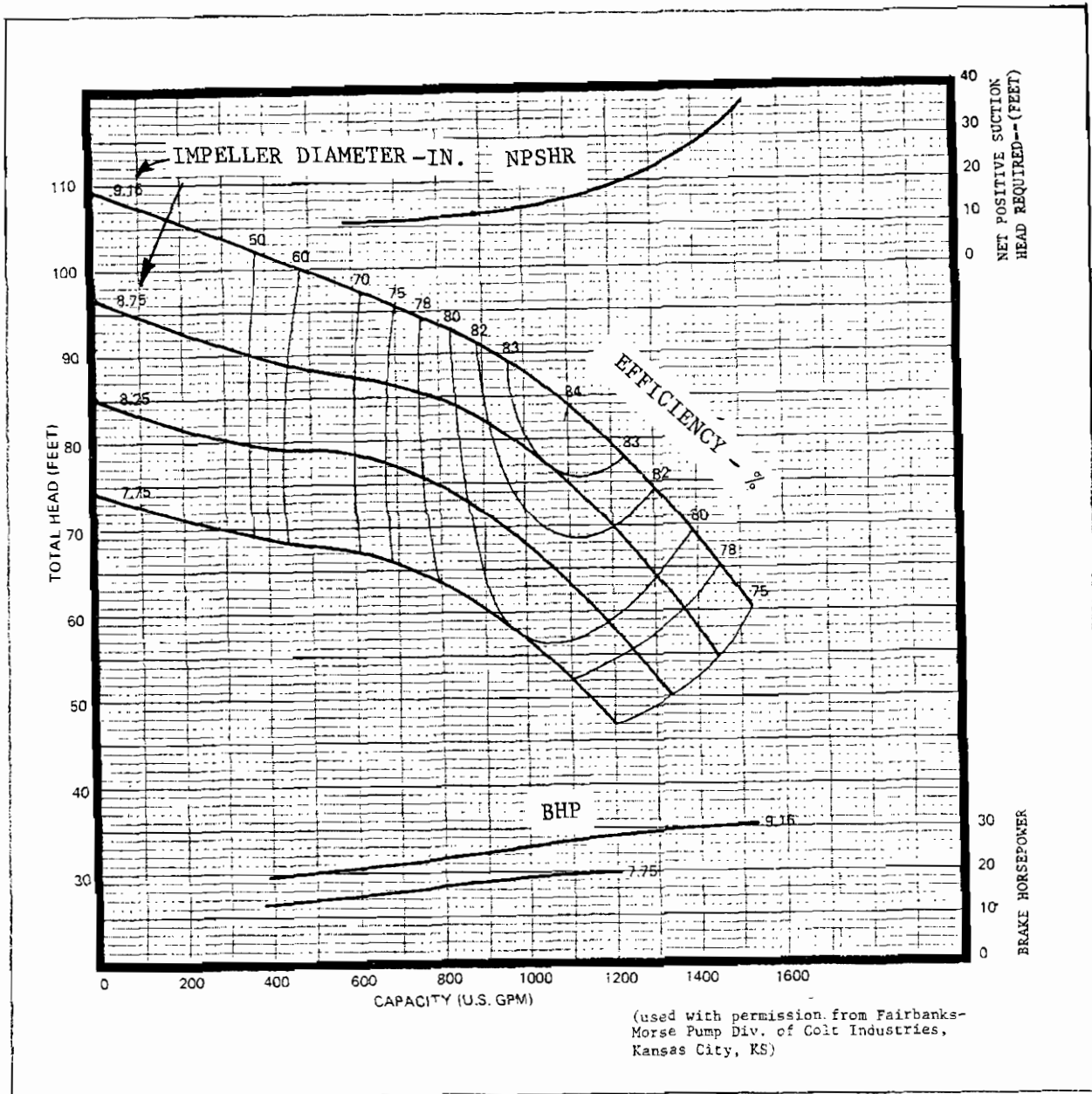

FIGURE 4. TYPICAL CHARACTERISTIC CURVES FOR A VERTICAL TURBINE PUMP

The selection of the proper sizes of pump column and shaft, type and numbers of bowls, spacing of bearings, and the matching of the various units of the pump to meet all well conditions have defied all attempts at simplification and standardization. Most companies offer data for which the various components of the pumping plant can be selected and matched to meet specific conditions. A typical characteristic curve for a vertical turbine pump is shown in Figure 4. With these data available from a number of established manufacturers that have field representatives available to consult on a comparison basis, no need was felt to include them in this engineering note. Advancing technology and the introduction of new materials and concepts soon outdate any published data currently available.

WELLS

Well Design

Well design, construction, development, and testing are the responsibilities of the driller and, hence, are outside the scope of this engineering note. Nevertheless, the purchaser should become aware of good well installation practices. The designer should seek out expertise in the quality and quantity of ground water in the local area. If there are no wells in the area, a geologist should be consulted. He would evaluate possibilities of ground water development by a study of published information and field investigation. Records of wells that indicate depths to water bearing formations or ground water reservoirs are often available by the U. S. Geological Survey, State Geological Surveys, State Bureau of Mines, and universities and colleges.

Well Size and Capacity

The inside diameter of the well casing should be 50 to 100 mm (2 to 4 in.) larger than the maximum outside diameter of the pump and pump column that are likely to be installed to allow the pump to hang freely in the well. Table 4 gives the recommended well casing sizes for various pumping rates.

Table 4. Recommended Well Diameters

Anticipated Well Yield gpm	Nominal Size of Pump Bowls	Smallest Size of Well Casing in.	Optimum Size of Well Casing
Less than 100	4	5 ID <u>1/</u>	6 ID
75 to 175	5	6 ID	8 ID
150 to 400	6	8 ID	10 ID
350 to 650	8	10 ID	12 ID
600 to 900	10	12 ID	14 OD
850 to 1300	12	14 OD <u>2/</u>	16 OD
1200 to 1800	14	16 OD	20 OD
1600 to 3000	16	20 OD	24 OD

1/ Inside diameter.

2/ Outside diameter.

The above figures are not limiting. Much depends on the water level, yield characteristics of the water bearing formation, and the pressure to be developed, but they serve as a general guide. Reports from the Mississippi Delta catfish producing area indicate that a much larger discharge is available from a relatively shallow aquifer (maximum depth 100-150 ft.).

Well Installation

It is good business to have a written contract. For both parties, a written agreement is valuable protection and prevents misunderstanding. The following information should be considered by the landowner when contracting for the installation of a well:

(1) Drilling Well

- a. Specify size of casing. If pump capacity is to be increased at a future date, select casing size large enough to accommodate the larger pump.
- b. A graded "gravel pack" should be installed around the screen.
- c. A sieve analysis should be run on the sand aquifer to determine gradation of gravel pack and size and length of screen.
- d. Driller should not use bentonite to prevent sides from caving in during drilling operation. Bentonite may clog the wall of the well, which will reduce the amount of water that can be drawn into the pump. Driller should use a biodegradable material that will dissipate in the water.
- e. Drill test well for deep wells.

(2) Well Screen

- a. A high capacity stainless steel screen is recommended. For naturally developed wells, the slot size should be small enough to exclude about one-third of the aquifer formation. For wells with filters, the slots in the screen should be less than the D_{85} size of the filter and larger than the D_{60} size. Run sieve analysis to determine screen size and openings.
- b. Louvered Screens - Openings usually inadequate.
- c. Slotted Pipe - Openings inadequate.
- d. Length of Screen - Long enough to hold drawdown to a minimum. Consult closely with manufacturer or supplier.
- e. Set screen at sufficient depth to minimize drawdown. The thickness and depth of the aquifer should determine depth of well.

(3) Pump

- a. Specify capacity.
- b. Pump Efficiency - The higher the pump efficiency, the less the operating cost.
- c. Stainless steel shaft.

- d. Oil or water lubricated? Oil recommended below 100 feet.
- e. Maximum RPM for water lubricated bearings - 2200.
- f. How many stages in the pump?
- g. Horsepower required to operate pump at design capacity.

(4) Testing Well

- a. Upon completion, test for drawdown and yield.
- b. Get copy of well test log.
- c. Log should show:
 - (1) static water level;
 - (2) pumping or dynamic level;
 - (3) amount of drawdown;
 - (4) capacity per foot of drawdown;
 - (5) depth of well;
 - (6) capacity of well after taking three readings an hour apart with no change in the three readings; and
 - (7) other pertinent data such as length of screen, percent openings, size of pump, etc.

(5) Warranty

- a. How long will the driller warrant the well?
- b. What will be done if the well starts pumping sand? (The well may pump a small amount of sand at first, but it should stop in a relatively short time.)
- c. It is best to contract for a guaranteed capacity for the well. If the driller knows that he will not be paid the contract price unless the well pumps the agreed to amount of water, he may do a better job installing the well.

POWER UNITS

Electric Motors

Electricity is a very satisfactory power source. The dependability and long life of electric motors make them a desirable power source. The most common type of motor for pumping plants is the 60-cycle, 220/440 volt, 3-phase, squirrel cage induction motor. The speed of these motors under full load is nearly constant.

The speed of the pump can only be changed by either the use of a belt drive and changing pulley diameters, or by selecting a gear drive with the proper ratio for the system. Direct connection between electric motor and pump is preferred to eliminate drive loss.

Single phase motors are often used for loads up to and including five horsepower. However, three-phase motors are more efficient. Above 5 to 7½ horsepower, single phase motors are not generally adapted. Electric motors above 5 horsepower will generally have an efficiency of between 88 to 90 percent. Most squirrel cage induction motors are designed to operate satisfactorily under a continuous overload of 10 to 15 percent; however, it is not wise to plan on an overload.

Electric motors should always be provided with protection against excessive heating due to overloading or undervoltage. In addition, larger motors will require a starter or starting compensator.

Internal Combustion Engines

Selection of an engine for a power source for pumping should be based on the continuous service rating, rather than the maximum BHP rating, with adequate allowance for high temperatures as well as power loss in drive components. When the continuous horsepower rating is not indicated, an assumption of 80 percent of the manufacturer's maximum BHP would be reasonable.

Manufacturers have developed performance curves for each of their engines. Manufacturers' test for horsepower output is determined in laboratory conditions with a stripped engine. Hence, the performance curve does not reflect the power loss when the engine is equipped with typical accessories such as fans, generators, water pumps, etc. These accessories may easily consume 10 percent of the engine's horsepower output.

Gasoline, diesel, and LP-gas are all used to drive pumping plants. Gasoline engines have two principal advantages over diesel and LP-gas engines. These are (a) lower initial cost, and (b) readily available maintenance and repair service. On the other hand, diesels have a longer life. LP-gas engines require less maintenance than gasoline and the fuel may cost less. Another advantage of LP-gas is that fuel is less subject to theft.

Pump Drives

The operating efficiency of pumping plants is dependent on the drive mechanism between the pump and motor. The common types of drives being used with pumping plants along with their efficiency ratings are as follows:

Direct connected -----	1.00
Right angle gear -----	0.95
V-belt -----	0.95
Flat belt -----	0.85

Drive Speed

The operating speed of the pump is dependent on the speed of the engine and the type of connecting drive between the pump and engine. A direct drive on either an electric or an internal combustion engine fixes the speed of the pump and power unit at a 1:1 ratio. With right angle gear drives or belts, the ratio of pump speed to engine speed depends on the gear or pulley ratio. The ratios stated in manufacturer's literature for both gear drives and pulley drives are those of the engine or driver versus those of the pump or whatever is being driven. For example, a ratio of 5:4 means an engine speed that is 5/4 or 1.25 times the pump speed.

This exercise can best be illustrated with an example problem:

A pump is selected with a speed rated at 1760 rpm. An internal combustion engine is chosen that operates at 2100 rpm. Because of differences in speed ratings, the engine and pump cannot be connected direct so a gear drive or belt connection is needed. Using a V-belt - pulley connection with an 8-inch diameter pulley on the engine, the size of pulley on the pump is computed as follows:

$$\text{The engine-pump speed ratio} = \frac{2100}{1760} = 1.19$$

The pulley on the engine is 8 inches; therefore, the pump pulley should be $9\frac{1}{2}$ inches (8×1.19) in diameter.

Power Requirements

To determine the actual horsepower of the power unit to drive a pump, it is necessary to know the following:

- (1) Flow (or discharge)
- (2) Pumping head (including friction in the piping system)
- (3) Pumping efficiency
- (4) Type of drive
- (5) Type of power unit.

The useful work done by a pump or the water horsepower (WHP) required is expressed by the formula:

$$\text{WHP} = \frac{\text{gpm} \times \text{total dynamic head (TDH)}}{3960} \quad (9)$$

The water horsepower is that required to operate the pump if both the pump and drive were 100 percent efficient.

The brake horsepower (BHP) required to operate a pump is determined by the equation:

$$\text{BHP} = \frac{\text{water horsepower (WHP)}}{\text{pump efficiency} \times \text{drive efficiency}} \quad (10)$$

Since electric motors are rated at 100 percent continuous operation, the power requirements are those to operate the pump plus any drive losses. When electric motors are connected to the pump directly, there are no drive losses to consider.

Example:

Given a 1770 rpm electric motor-driven pump with direct drive that is to deliver 1200 gpm at 120 ft. TDH. Pump efficiency from manufacturer is 75 percent. Find the motor size.

Solution:

$$\text{Equation (10) BHP} = \frac{1200 \times 120}{3960 \times 0.75} = 48.48$$

Use a 50 HP motor.

Power requirements for internal combustion engines must exceed the required HP to drive the pump by an amount to offset losses for accessories, elevation and temperature, and to provide for continuous operation.

Typical corrections for internal combustion engine losses are as follows:

	<u>Loss - (percent)</u>
(1) Continuous load operation -----	20
(2) Accessories -----	5
(3) Elevation -----	3 percent for each 1000 ft. above sea level
(4) Temperature -----	1 percent for each 10° increase above 60°F

Fuel Cost

For a high water use crop such as catfish, fuel cost is a major item. To determine the fuel cost for pumping, use current prices for diesel, LP gas, and electricity. For this example, the following assumptions are made:

Example:

The price of fuel--diesel at \$1.10 and 14.58 brake horsepower hours per gallon, LP gas at 65 cents and 9.2 brake horsepower hours per gallon, and electricity at six cents and 1.18 brake horsepower hours per kilowatt hour.

The pumping assumptions are 2,000 gallons per minute with a 60 foot pumping lift with open discharge and 70 percent efficiency.

On this basis, it will require approximately 43.3 brake horsepower to operate the pump. Using the assumptions outlined here, the fuel cost for pumping one acre-inch of water is 73 cents for diesel, 69 cents for LP gas, and 50 cents for electricity.

If the total water pumped to grow a crop of catfish is estimated to be 72.0 inches, the per acre fuel cost will be approximately \$52.56 for diesel, \$49.68 for LP gas, and \$36.00 for electricity.

The total pumping cost for 80 acres of catfish would be \$4,205 for diesel, \$3,975 for LP gas, and \$2,880 for electricity.

Table 5. Flow of Water in Cast Iron Pipe
Head Loss in Ft./1000 Ft.

Hazen-Williams Formula, C=130

Flow in Gallons Per Minute	Diameter of Pipe in Inches			
	6	8	10	12
50	0.32	0.08		
100	1.05	0.25	0.09	
200	3.75	0.92	0.32	0.13
300	8.00	2.00	0.66	0.27
400	13.0	3.20	1.10	0.44
500	19.5	5.0	1.7	0.67
750	-	10.0	3.5	1.42
1,000	-	17.5	5.8	2.40
1,500	-	-	12.5	5.0
2,000	-	-	19.6	8.4
2,500	-	-	-	12.8
3,000	-	-	-	17.6

Table 6. Flow of Water in Plastic (PVC) Pipe
Head Loss in Ft./1000 Ft.

Hazen Williams Formula, C=150
Pressure Class = 200, DR = 14

Flow in Gallons Per Minute	Diameter of Pipe in Inches			
	6	8	10	12
50	0.25	-	-	-
100	0.92	0.24	-	-
200	3.31	0.88	0.33	-
300	7.6	1.87	0.69	0.30
400	11.9	3.19	1.18	0.51
500	18.1	4.82	1.79	0.77
700	-	9.0	3.33	1.43
1,000	-	17.4	6.45	2.76
1,400	-	-	12.0	5.18
2,000	-	-	23.3	10.0
2,500	-	-	-	15.2
3,000	-	-	-	21.2

Table 7. Flow of Water in Asbestos Cement Pressure Pipe
Head Loss in Ft./1000 Ft.

Scobey's Formula, Ks = 0.32

Flow in Gallons Per Minute	Diameter of Pipe in Inches			
	6	8	10	12
200	3.72	-	-	-
300	8.0	-	-	-
400	13.9	3.21	-	-
500	21.2	4.95	-	-
750	-	10.7	3.28	-
1,000	-	18.5	5.64	2.32
1,500	-	-	12.2	5.0
2,000	-	-	21.1	8.6
2,400	-	-	-	12.3
3,000	-	-	-	18.7

Table 8. Flow of Water in Welded Steel Pipe 15 Years Old
Head Loss in Ft./1000 Ft.

Scobey's Formula, $K_s = 0.36$
Wall Thickness = 12 gauge

Flow in Gallons Per Minute	Diameter of Pipe in Inches			
	6	8	10	12
100	1.15	-	-	-
200	4.29	1.0	-	-
300	9.5	2.23	0.72	-
400	16.3	3.81	1.24	0.55
500	24.9	5.8	1.89	.80
750	-	12.8	4.5	1.75
1,000	-	21.8	7.7	3.00
1,500	-	-	16.0	6.5
2,000	-	-	26.5	10.6
2,500	-	-	-	16.5
3,000	-	-	-	23.0

Table 9. Flow of Water in Aluminum Pipe
Head Loss in Ft./1000 Ft.

Hazen-Williams Formula, $C=120$
(30-foot pipe lengths)^{1/}

Flow in Gallons Per Minute	Diameter of Pipe in Inches			
	6	8	10	12
100	1.20	-	-	-
200	4.50	1.1	-	-
300	9.4	2.6	0.78	-
400	16.0	4.0	1.30	0.55
500	25.0	6.0	2.0	0.80
750	-	12.6	4.3	1.75
1,000	-	21.5	7.2	3.0
1,500	-	-	16.0	6.5
2,000	-	-	26.5	10.6
2,500	-	-	-	16.5
3,000	-	-	-	23.0

^{1/} Where 20-foot lengths of pipe are used, increase values by 7.0%
Where 40-foot lengths of pipe are used, decrease values by 3.0%

TABLE 10. FLOW MEASUREMENT

Estimating Flow From Horizontal or Inclined Pipes

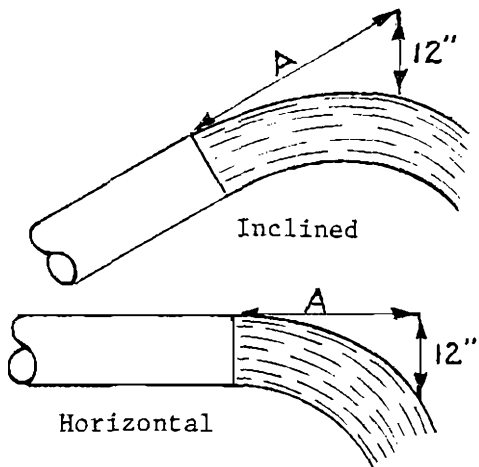

(Full Pipes)

A fairly close determination of the flow from full open pipes may be made by measuring the distance the stream of water travels parallel to the pipe in falling 12 inches vertically.

Measure the inside diameter of the pipe accurately (in inches) and the distance (A) the stream travels in inches parallel to the pipe for a 12-inch vertical drop. (see diagrams)

The flow, in gallons per minute, equals the distance (A) in inches multiplied by a constant K obtained from the following table:

I.D. Pipe	K	I.D. Pipe	K	I.D. Pipe	K	I.D. Pipe	K	I.D. Pipe	K	I.D. Pipe	K
2	3.3	4	13.1	6	29.4	8	52.3	10	81.7	12	118.
1/4	4.1	1/4	14.7	1/4	31.9	1/4	55.6	1/4	85.9	1/2	128.
1/2	5.1	1/2	16.5	1/2	34.5	1/2	59.0	1/2	90.1	13	138.
3/4	6.2	3/4	18.4	3/4	37.2	3/4	62.5	3/4	94.4	1/2	149.
3	7.3	5	20.4	7	40.0	9	66.2	11	98.9	14	160.
1/4	8.6	1/4	22.5	1/4	42.9	1/4	69.9	1/4	103.	1/2	172.
1/2	10.0	1/2	24.7	1/2	45.9	1/2	73.7	1/2	108.	15	184.
3/4	11.5	3/4	27.0	3/4	49.0	3/4	77.7	3/4	113.	16	209.

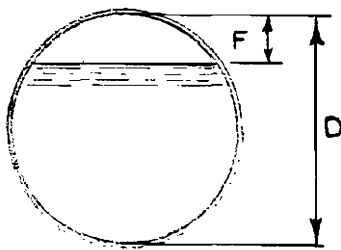

(Partially Filled Pipes)

For partially filled pipes, measure the freeboard (F) and the inside diameter (D) and calculate the ratio of F/D (in percent). Measure the stream as explained above for full pipes and calculate the discharge. The actual discharge will be approximately the value for a full pipe of the same diameter multiplied by the correction factor from the following table:

F/D Percent	Factor	F/D Percent	Factor	F/D Percent	Factor	F/D Percent	Factor
5	0.981	30	0.747	55	0.436	80	0.142
10	.948	35	.688	60	.375	85	.095
15	.905	40	.627	65	.312	90	.052
20	.858	45	.564	70	.253	95	.019
25	.805	50	.500	75	.195	100	.000

STEP-BY-STEP PROCEDURE FOR DESIGN OF A PUMPING PLANT

This information can best be explained by an example based on the following conditions:

Size of pond -----	35 Ac (133 Ac-Ft)
Time to fill pond by pumping -----	30 days
Elevation of well site (adjacent to pond) -----	980 ft.
Max. operating temperature -----	100°F
Pumping lift at well -----	140 ft.
Static discharge head -----	6 ft.
Assumed pump efficiency -----	75%
Pump speed -----	1760 rpm
Length of discharge pipe (smooth steel) -----	40 ft.

Find:

- Pumping requirements in gpm.
- Capacity of an electric motor that will operate the pump with a direct drive.
- Capacity of an internal combustion engine that will operate the pump with a V-belt drive and equipped with the usual accessories.
- Capacity of an electric motor to operate a centrifugal pump located adjacent to a large reservoir 1000 ft. away from pond with a total pumping lift of 82 ft. and using plastic (PVC) pipe with a pressure class of 200.

Solution:

$$(a) \text{ Pumping requirements} = \frac{133 \text{ Ac-ft.}}{30 \text{ days}} = 4.43 \text{ Ac-Ft/day}$$

$$4.43 \times 226.3 \text{ gal/min} = 1003 \text{ gpm (Eq. 5)}$$

use 1000 gpm

From Table 4 a well casing diameter of 16 inches to accommodate a deep well turbine pump is recommended. The discharge pipe from the pump can be either 8 or 10 inches in diameter. (Table 8)

- (b) Capacity of an electric motor with direct drive.

$$\text{BHP} = \frac{\text{GPM} \times \text{TDH}}{3960 \times \text{pump eff.}} \quad (\text{Eq. 10})$$

Total Dynamic Head (TDH) = pumping lift + discharge head +
friction head in discharge pipe

$$\text{TDH} = 140 + 6 + (40' \times .0071) = 146.28$$

$$\text{BHP} = \frac{1000 \times 146.28}{3960 \times .75} = 49.25$$

Use a 50 HP motor

- (c) Capacity of an internal combustion engine with V-belt drive

$$\text{BHP} = \frac{\text{GPM} \times \text{TDH}}{3960 \times \text{pump eff.} \times \text{drive eff.} \times \text{temp. \& elev. losses}}$$

$$\text{BHP} = \frac{1000 \times 146.28}{3960 \times .75 \times .95 \times .96 \times .97} = 55.7$$

For continuous load operations, use an engine rated for maximum
brake horsepower of 69.6 or greater (20% loss)

- (d) Capacity of an electric motor to operate a centrifugal pump
1000 ft. from pond with a total pumping lift of 82 ft. using
pressure class 200 plastic (PVC) pipe.

1st Trial - using 8 in. pipe

Friction loss in discharge pipe (8 inches) = 17.4 ft. (Table 6)
Total Dynamic Head (TDH) = 82 + 17.4 = 100 ft. (rounded)

$$\text{BHP} = \frac{\text{GPM} \times \text{TDH}}{3960 \times \text{pump eff.}}$$

$$\text{BHP} = \frac{1000 \times 100}{3960 \times .75} = 33.7$$

The next larger size electric motor will probably be 40 HP.

Note: Using 10" PVC pipe with a friction head loss of 6.45 ft.
(Table 6), the size of electric motor is computed at 30 HP.

MAINTENANCE

Below Standard Performance

Any of the three major components of the pumping plant; pump, drive, or power unit, can cause poor performance. In addition, mismatching of components, poor selection of components, or changing water levels may cause reduced efficiency.

The Pump - A pump's impeller(s) can be out of adjustment. Impellers out of adjustment require greater than normal pump and engine speeds to deliver a specified amount of water. Worn or corroded impellers cannot be brought back to original capacity, head, or efficiency by adjustment.

For centrifugal pumps, warping of the pump case or bending of the pump shaft may cause increased friction of the rotating part. Pumping units and piping systems are never completely static. There is always some movement due to expansion and shrinkage. Periodic inspection and corrections are essential for trouble free operation.

The Power Unit - A power unit can require more fuel than normal if it is not loaded properly, not serviced adequately, not "tuned" correctly, or if it contains worn components. A power unit should be serviced at regular intervals and should be winterized for the off season. The efficiency of electric motors will be reduced if they are underloaded. If they are overloaded according to the service factor, efficiency may not be reduced but motor life will be shortened.

The Drive - The drive ratio must be correctly matched to the pump engine speeds. Drive misalignment will increase friction and reduce driveline life.

Performance Test

A pumping plant performance test can determine the energy efficiency of a pumping plant as well as provide information on adjustments needed to improve energy efficiency and extend pumping plant operating life. The performance of a pumping plant should be evaluated by trained personnel using accurate and reliable testing equipment. This service can be performed by consulting engineers, by many well drilling companies, by some University and Extension Service personnel, and some Public Power Districts. A pumping plant test should be performed regardless of the age of the system. The information obtained during the test includes water levels while pumping, discharge pressure, pump and engine speed, and energy use per hour. Conditions such as pumping sand or air are noted.

REFERENCES

Agricultural Pumps. First Edition. Fairbanks-Morse Pump Division, Colt Industries. Kansas City, Missouri.

American Society of Agricultural Engineers, ASAE Engineering Practice: ASAE EP400. Designing and Constructing Irrigation Wells. St. Joseph, Michigan: Agricultural Engineers Yearbook, 1981.

- Brater, Ernest F., and Horace Williams King. Handbook of Hydraulics. Sixth Edition. New York: McGraw-Hill, 1976.
- Engineering Field Manual, Chapter 12, Springs and Wells. Soil Conservation Service, U. S. Department of Agriculture.
- Ground Water and Wells. Johnson Division, Universal Oil Products Co., Saint Paul, Minnesota: 1974.
- Harrison, Dalton S., and Rush E. Choate. Selection of Pumps and Power Units for Irrigation Systems in Florida. Agricultural Extension Service, Circular 330. University of Florida: 1969.
- Hydraulic Institute Standards for Centrifugal Rotary and Reciprocating Pumps. 12th Edition. Published by Hydraulic Institute, 122 East 42nd Street, New York, NY: 1969.
- King, Horace W., Chester O. Wisler, and James G. Woodburn. Hydraulics. Fifth Edition. New York: John Wiley & Sons, 1948.
- Lane, D. E. Engineering the Irrigation Pumping Plant. Cooperative Extension Service, Extension Circular 71-799. University of Nebraska: 1971.
- Machmeier, Roger E. Irrigation Wells. Agricultural Extension Service, Extension Bulletin M-158. University of Minnesota: 1972.
- National Engineering Handbook, Section 5, Hydraulics. Soil Conservation Service, U. S. Department of Agriculture.
- National Engineering Handbook, Section 8, Engineering Geology. Soil Conservation Service, U. S. Department of Agriculture.
- National Engineering Handbook, Section 15, Irrigation. Soil Conservation Service, U. S. Department of Agriculture.
- National Engineering Handbook, Section 16, Drainage of Agricultural Land. Soil Conservation Service, U. S. Department of Agriculture.
- Pipe Economy. Clow Corporation. Bensenville, Illinois: 1971.
- PVC Pipe, Design and Installation. American Water Works Association, Manual No. M23. Denver, Colorado: 1980.
- Walker, Rodger. Pump Selection - A Consultant Engineers Manual. Ann Arbor Science Publishers, Inc. Michigan: 1979.
- Williams, Gardner S., and Allen Hazen. Hydraulic Tables. Third Edition. New York: John Wiley & Sons, 1949.

C

..

C

C



11

