

May 1971

Soil Mechanics Note No. 3: Soil Mechanics Considerations for
Embankment Drains

I. Purpose and Scope

This Soil Mechanics Note is a guide for the design of drainage for embankments and associated foundations. Each drain type is related to applicable site conditions so that the appropriate type or types may be incorporated in a drainage system. Recommended processes are given for determining drain dimensions and outlet sizes. In the procedures presented, seepage quantities to be drained and permeability coefficients of materials involved are known. Examples are given in Appendix C.

II. Definitions

- A. Interceptor drain - a drain that physically intercepts flow paths or fully penetrates water bearing strata.
- B. Pressure relief drain - a drain that produces an area of low pressure to which water will flow from adjacent areas of higher pressure.
- C. Filter material - a layer or combination of layers of pervious materials designed and installed in such a manner as to provide for water movement, yet prevent movement of soil particles due to flowing water.
- D. Drain material - sand, gravel, or rock that has specific gradation limits designed for required permeability and internal stability.
- E. Base material - any material (embankment, backfill, foundation or other filter layer) through which water moves into a drainage system.
- F. Coefficient of permeability - the rate of discharge of water under laminar flow conditions through a unit cross-sectional area of a porous medium under a unit hydraulic gradient and standard temperature conditions.

This Note was prepared by:

Clarence E. Dennis, Soil Mechanics Engineer, Lincoln EWP Unit
Robert E. Nelson, Soil Mechanics Engineer, Upper Darby EWP Unit
Roland B. Phillips, Soil Mechanics Engineer, Fort Worth EWP Unit
Jack C. Stevenson, Soil Mechanics Engineer, Portland EWP Unit

Comments by M. M. Culp, Chief, Design Branch, and R. S. Decker, Head, Soil Mechanics Unit, were very helpful.

III. Functions of drains.

Drains are included in embankments and foundations for two basic reasons:

- A. To prevent piping by controlling migration of soil particles under seepage flow. Materials fulfilling the requirements of Soil Mechanics Note No. 1 will control migration.
- B. To control pressure build-up by providing adequate capacity to carry the seepage flow.

There are no hard and fast rules for selecting a reasonable margin of safety for drain design. Judgment in this respect must be related to (1) past experience with similar materials, (2) the detail used in site investigation and testing programs, and (3) the limitations that analyses have in representing site conditions.

Some individuals prefer to estimate seepage quantities as realistically as possible and factor these quantities for the design discharge. Others prefer to apply a factor to the drain dimensions as the final step. There are also many situations where ample capacity can be provided by selecting a highly pervious drain material. A factor of ten is often used. However, this should not be accepted across the board because there are situations where a lesser margin is adequate and there are situations where a greater margin is needed. Regardless of the approach used, the designer must be careful not to compound safety by entering a factor into each of the steps involved in the design process.

IV. Types of drains and their application.

- A. Vertical and sloping embankment drains.

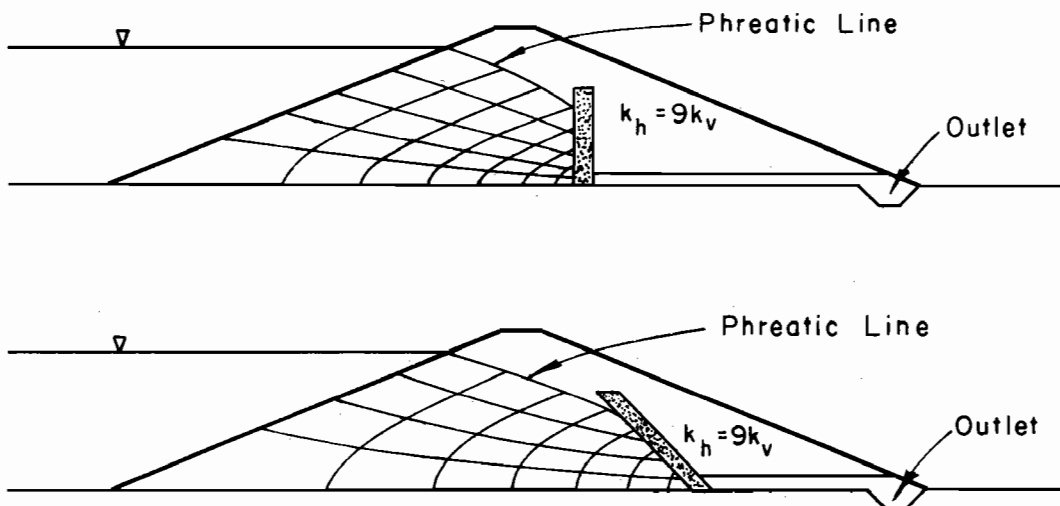

Vertical and sloping embankment drains are primarily interceptors that provide positive control of embankment seepage.

1. Site conditions where applicable.

a. Embankment material not susceptible to cracking:

In this case, water that percolates through the soil is intercepted to insure that seepage does not occur in materials downstream from the drain. This applies when:

- (1) The horizontal permeability of the embankment is significantly higher than the vertical permeability of the embankment. It is not possible to obtain isotropy in embankments constructed from fine-grained soils or from coarse-grained soils that contain fines. This is due in part to construction methods but mostly to non-uniformity in soil deposits. The degree of anisotropy to use in design is a matter of judgment because there is no good way to determine this property either before or after construction. The following table, which is from "Earth and Earth Rock Dams" by James L. Sherard et al, 1963, John Wiley and Sons, Inc., page 368, is considered to be a conservative guide.

Description of Soil in Borrow Area	k_h/k_v
Very uniform deposit of fine-grained soil (CL and ML)	9
Very uniform deposit of coarse soils with fines (GC and GM)	25
Very erratic soil deposits	100 or higher

- (2) Stability and/or durability of downstream embankment material is such that it cannot be allowed to saturate.

Variability of soils in many borrow sources is so great that the engineering properties of the resulting fill cannot be determined with any reasonable degree of accuracy. It may be more economical to place these materials in a "random fill" zone downstream from a positive drain than to either waste them or disregard them altogether.

If used, materials suspect of undergoing marked and unpredictable changes upon saturation should be placed where they cannot saturate. Soils containing concentrations of soluble salts and some of the "degradable" shale derivatives are examples.

- b. Embankment material susceptible to cracking: In this case, water which comes primarily through cracks formed within the embankment is intercepted to prevent piping and insure overall safety of the dam. This applies when:
 - (1) Cracks develop as a result of movements (differential settlement, seismic, etc.).
 - (2) Cracks develop as a result of desiccation.(Note: Other factors may contribute to development of cracks.)

2. Information required from the investigation.

- a. Index properties of base materials.
- b. Information needed to evaluate settlement profiles.
 - (1) Boundaries of compressible foundation soils and of bedrock surfaces.
 - (2) Compressibility of embankment and foundation soils.
 - (3) Water table conditions and drainage characteristics of foundation soils.
- c. Factors contributing to desiccation cracking such as climatic conditions and shrink-swell characteristics of embankment soils.
- d. Earthquake potential.
- e. Permeabilities of base materials.
- f. Gradations and permeabilities of available drain materials.

3. Design procedures and considerations.

- a. Embankment material not susceptible to cracking. Use Figure No. 1, which is based on flow net solutions, for proportioning the drain. If the slope is steeper than 1/2:1, use values for a slope of 1/2:1.
- b. Embankment material susceptible to cracking. Design depends on the following:
 - (1) The drain must have sufficient thickness so it will not be disrupted by the amount of movement that can occur. A minimum horizontal thickness of 10 feet is suggested on 1:1 slopes and steeper. Horizontal thickness should be increased on flatter slopes.
 - (2) Drain material must be internally stable and self-healing (well graded), with D85 size > 2 in. Care must be taken to prevent segregation.
 - (3) Drain material must be free flowing and deformable without cracking (clean and free of any cementing materials).
 - (4) Drain materials must be pervious enough to remove anticipated flow in the cross-sectional area provided.
 - (5) Drain material must be graded to control migration of base materials. When it is not possible to meet this requirement with a single drain material, an appropriate filter with a minimum horizontal thickness as suggested for the drain fill in (1) above will be provided in addition to the drain material.

Note: An example is not included in Appendix "C". Special study is required when cracking is anticipated.

B. Horizontal blanket drain.

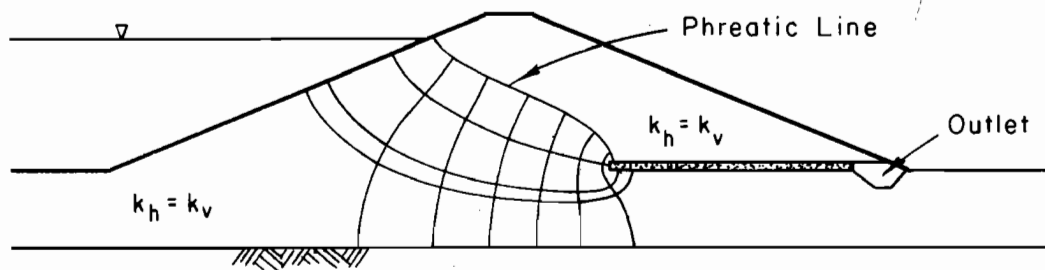

The horizontal blanket drain is primarily a pressure relief drain placed in the downstream area of an embankment.

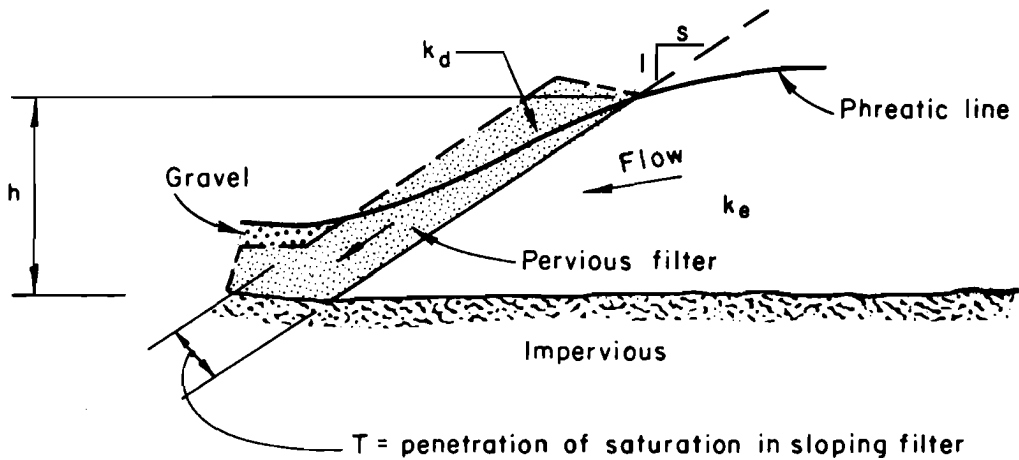
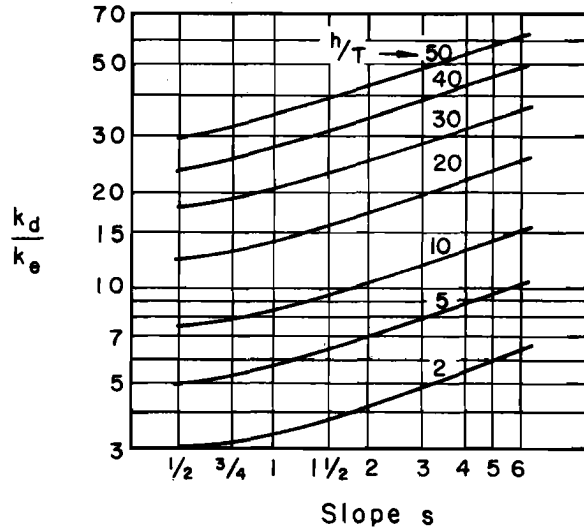
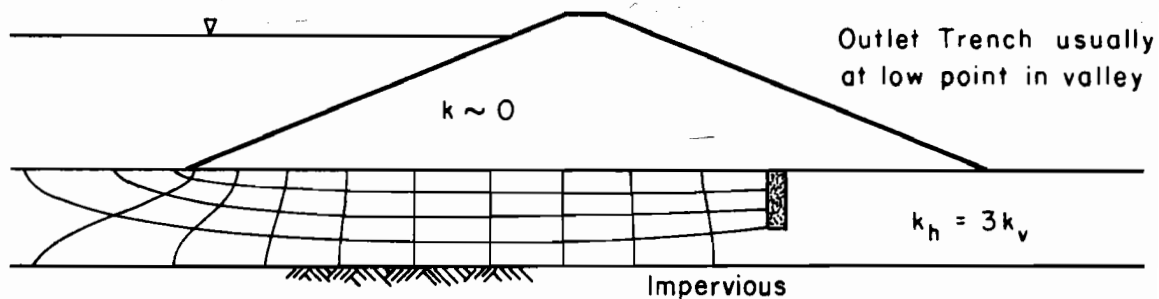

Figure 1. Flow net solution for seepage into sloping filters on various slopes. (Adapted from Harry R. Cedergren, Seepage, Drainage and Flow Nets, 1967, John Wiley and Sons, Inc., page 195, Fig. 5.10)

1. Site conditions where applicable.
 - a. When there is no significant difference between the vertical and horizontal permeabilities of the embankment and/or the foundation.
 - b. When bedrock is pervious (drain placed directly on bedrock).
 - c. When a good bond cannot be obtained between impervious bedrock and the embankment.
2. Information required from the investigation.
 - a. Extent and elevation of the water table.
 - b. Index properties of the base materials.
 - c. Extent and configuration of the base materials including the location of impervious boundaries.
 - d. Permeabilities of base materials and condition of the bedrock.
 - e. Gradations and permeabilities of available drain materials.
3. Design procedures.

Use Darcy's law, $q = kiA$, for solution.
4. Flow in blanket drains placed on abutments is essentially down slope. Information required from the investigation is the same as that required for horizontal blanket drains. Design procedures outlined for vertical embankment drains are applicable, i.e., Figure 1 or Darcy's law can be used.

C. Foundation trench drain.



The foundation trench drain is primarily a pressure relief drain. It is most effective when it penetrates all pervious strata.

1. Site conditions where applicable.
 - a. When horizontal permeability of the foundation is significantly greater than vertical permeability of the foundation.
 - b. To relieve pressure from foundation aquifers.
 - c. To control pipable foundation materials.
2. Information required from the investigation.
 - a. Extent and elevation of the water table.
 - b. Magnitude of water pressure in any aquifers.
 - c. Index properties of base materials.
 - d. Thickness of base materials and their position.
 - e. Continuity or discontinuity of base materials (upstream, downstream and across the valley) and the location of impervious boundaries.
 - f. Permeabilities of the base materials.
 - g. Gradations and permeabilities of available drain materials.
3. Design procedures.
 - a. Foundation trench drains without pipe. Use Darcy's law, $q = kiA$.
 - b. Foundation trench drains with pipe.
 - (1) Proportion the drain fill to carry at least 50% of the design discharge.
 - (2) Proportion the pipe to carry at least 50% of the design discharge with the pipe $3/4$ full.

There is not much information in the literature on capacity of drains with pipes that applies to dams. Appendix "A" contains a brief review of a few studies that have some application and concludes with a suggested design approach for perforated pipe placed in gravel drain material.

D. Relief wells.

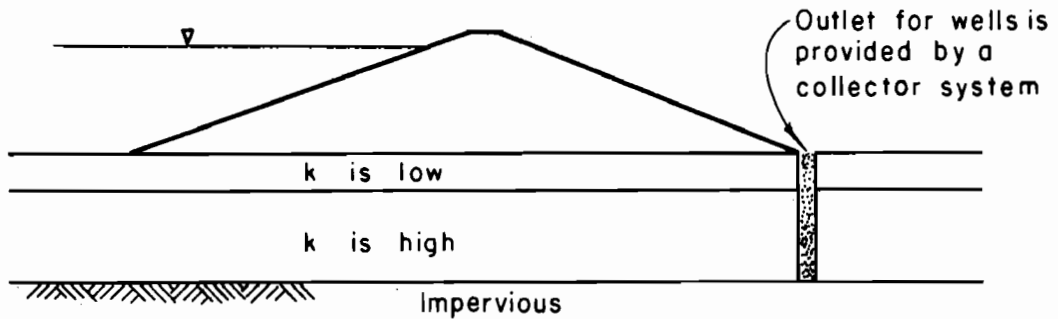

Relief wells are pressure relief drains. They are generally located near the downstream toe of an embankment for accessibility.

1. Site conditions where applicable.

Relief wells are particularly adapted for control of pressures from confined aquifers that are too deep to drain with trenches including deep, stratified alluvial deposits having significant differences in permeability of the various strata.

2. Information required from the investigation.

- a. Extent and elevation of the water table.
- b. Magnitude of water pressures within the aquifers.
- c. Index properties of base materials.
- d. Thickness of the aquifer and the confining materials.
- e. Continuity or discontinuity of the aquifer and the confining materials (upstream, downstream, and across the valley), including the location of impervious boundaries.
- f. Permeability of the aquifer and the confining materials.
- g. Gradations and permeabilities of available sand or gravel pack materials.

3. Design procedures.

- a. Deferred action approach.

When it is either impractical or impossible to evaluate all the factors in Section 2 above to the degree necessary for design of relief wells during the design stage, proceed as follows:

- (1) Install piezometers during construction so that pressure relationships may be established for the critical areas.
- (2) Monitor pressures until they stabilize under a given reservoir level (a level that is believed to be safe).
- (3) Compare measured pressures to allowable pressures and evaluate need for relief (measured pressures may have to be adjusted to full reservoir head).
- (4) When needed, design the relief well system using measured or adjusted pressures and the procedures given in "Design of Finite Relief Well Systems", Corps of Engineers EM 1110-2-1905 dated March 1, 1963, or the procedures outlined in Appendix B.

b. Design prior to construction.

When all of the factors in Section 2 above can be evaluated reasonably well or conservatively estimated prior to design:

- (1) Estimate uplift in critical areas (usually along the downstream toe). Methods similar to those given in "The Effect of Blankets on Seepage Through Pervious Foundations", by P. T. Bennett, ASCE Transactions, Vol. 111, 1946, and in the SM-10 Manual, Chapter 12, pages 12-19 to 12-21, may be used to estimate uplift pressures. These methods should not be used when there is insufficient evidence from the investigation to prove that an aquifer is continuous for considerable distances upstream and downstream from the dam. When it is known that continuity does not exist, the only recourse is to estimate uplift pressures conservatively.
- (2) If uplift is detrimental, base the design on procedures given in "Design of Finite Relief Well Systems", Corps of Engineers EM 1110-2-1905 dated March 1, 1963, or those given in Appendix B.

Note: Design changes may be needed when additional information becomes available during construction or after the structure is in operation, even though all factors appeared to be clear-cut at the time of design.

V. Drain Outlets

A drain outlet is a section of the system that has the primary purpose of conducting accumulated seepage to a controlled discharge point.

A. Types

1. Transverse (essentially perpendicular to the embankment centerline)
 - a. Outlet for foundation trench drain.
 - b. Outlet for vertical embankment drain.
 - c. Outlet for abutment drains.
 - d. Outlet for springs.
 2. Longitudinal (essentially parallel to the embankment centerline)
 - a. Outlet for a blanket drain (usually placed at the downstream toe).
 - b. Outlet for relief wells.
- B. Design procedures for outlets are similar to those presented for drains.

VI. Special Situations

- A. Embankment zones. When an embankment zone is to function as a drain, material placed in that zone must meet the permeability and piping requirements for drain material. On-site materials generally contain enough fines to limit permeability. Permeability determinations and flow nets will provide guidance on the effectiveness of these materials for drainage zones.
- B. Springs. It may be necessary to increase the capacity of drains to accommodate flow from springs. In many cases, it is desirable to provide separate drainage outlets for springs.
- C. External abutment drains. Drains outside the limits of an embankment will be designed by the procedures outlined for drains placed under embankments.
- D. Abutment well drains. These are either horizontal or slanted wells for drainage of deeply fractured rock abutments and other deep, pervious abutment materials. Design procedures are outside the scope of this note.

- E. Compressible foundations. When drains with pipes are placed on or in compressible foundation soils, settlement profiles will be evaluated and pipe grades adjusted to accommodate for settlements.

Appendix A

Pipes in Drains

This appendix contains an approach for sizing of pipes installed in drains. Two flow conditions are considered: (1) flow through openings into the pipe is based on orifice flow with an area reduction to account for blockage by particles and (2) flow in the pipe is based on open channel flow.

Review of many papers dealing with pipes in drains yielded only a small amount of data on head-discharge relationships for perforations or slots. Information from three studies is plotted on Figure A-1, Head-discharge relationship for pipe perforations. Gradation of the drain material surrounding these pipes is shown on Figure A-2. Comments on the head-discharge curves are as follows:

1. A comparison of the curve for $Q = CA\sqrt{2gh}$, $C = 0.6$, and curve No. 1, pipe in water only, indicates that a coefficient of discharge of 0.6 is reasonable for the perforations in this uncoated corrugated metal pipe.
2. With the uncoated corrugated metal pipe imbedded in medium SP, curve No. 2, discharge through the perforations is about 10% of the discharge without sand around the pipe.
3. The range represented by No. 3 shows that discharge through perforations of this coated corrugated metal pipe placed in coarse SP is about 20% of the discharge with the pipe in water only and assuming that $C = 0.6$.
4. Curve No. 4 is for flow into clay pipe with a wall thickness of $5/8$ in. The perforation length to diameter ratio is 2.5, in the range of short tubes, where a discharge coefficient of 0.8 is normal. Flow through joints could not be separated from flow through perforations and it is not known how this would affect the discharge coefficient. Even assuming that $C = 1.0$, discharge through openings in this pipe placed in GP is greater than 80% of that without restriction.

In a recent study, "Laboratory Tests of Relief Well Filters", Report No. 1, MP S-68-4, Waterways Experiment Station, Corps of Engineers, two clean sands and a fine gravel were placed around a wood screen having $3/16$ in. (4.76 mm) slots. Discharges were measured before and after surging and the unclogged slot area was determined by observation after testing. The D_{50} size of the finer sand was 2.7 mm. and the unclogged slot area was 20% of the total. The coarser sand had a D_{50} size of 3.6 mm. and an unclogged slot area of 50%. The gravel had a D_{50} size of 4.7 mm. (about the slot width) and an unclogged slot area of 70%.

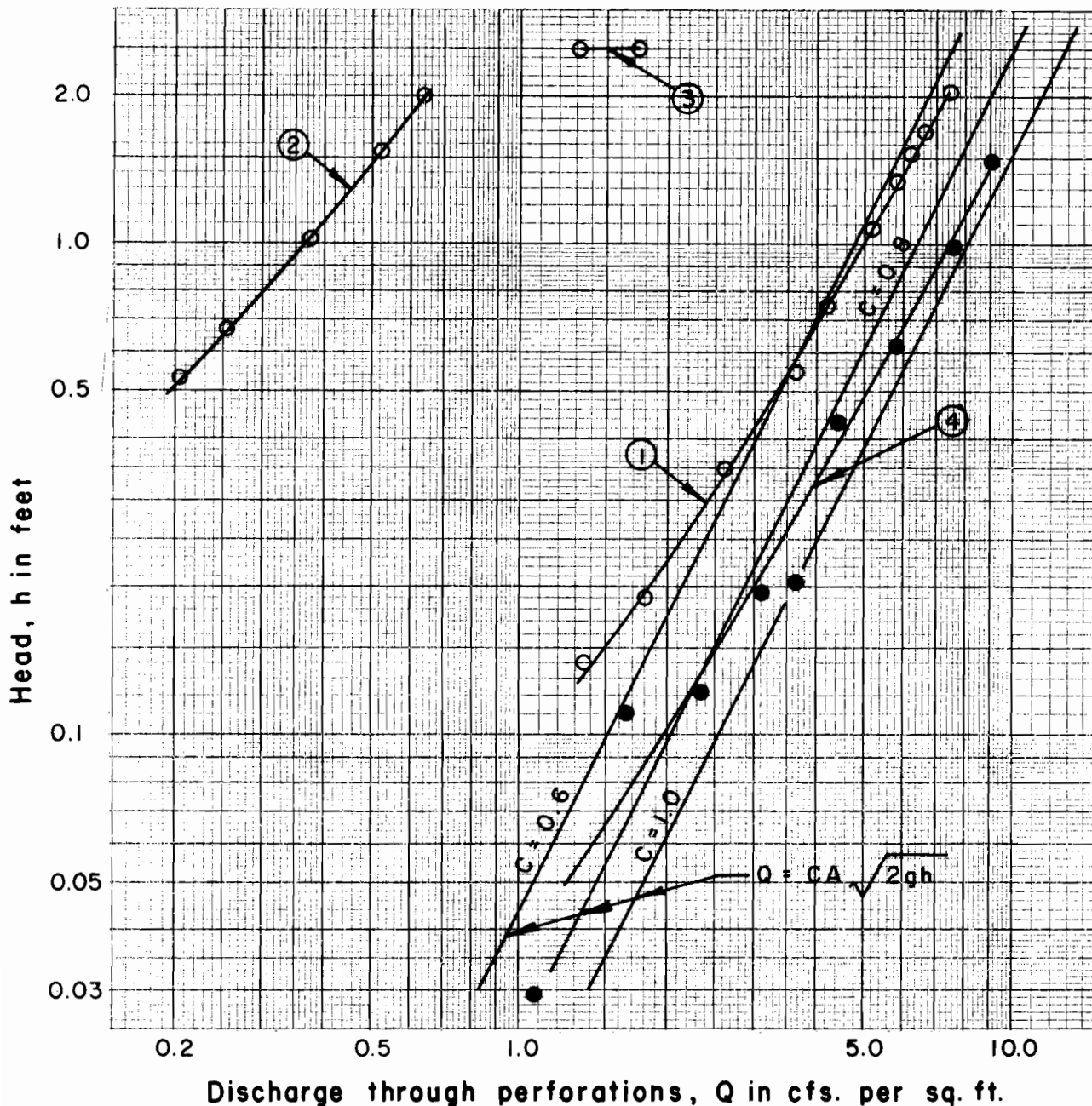

- ① From First Progress Report on Performance of Filter Materials, J. C. Gillou, Univ. of Ill., 1960. 8 in. dia. cmp., 5/16 in. perforations, assuming 16 per foot. Pipe in water only.
- ② Same as ① but with pipe in medium SP, gradation 1, Fig. A-2.
- ③ From WES TM 183-1, 1941. 6 in. dia. coated cmp., effective perforation dia. 3/16 in., 40 per foot. Pipe in coarse SP, gradation 2, Fig. A-2.
- ④ From Spindletop Research Report 580, 1967. 6 in. dia. clay pipe, 1/4 in. perforations, 44 per 3 ft. length, wall thickness 5/8 in. Pipe in GP equivalent to Indiana No. 7 Stone, gradation 3, Fig. A-2. Joints considered as perforations for curve.

Figure A-1. Head-discharge relationship for pipe perforations.

Figure A-2. Gradation of drain material used in the studies from which Fig. A-1 curves were developed.

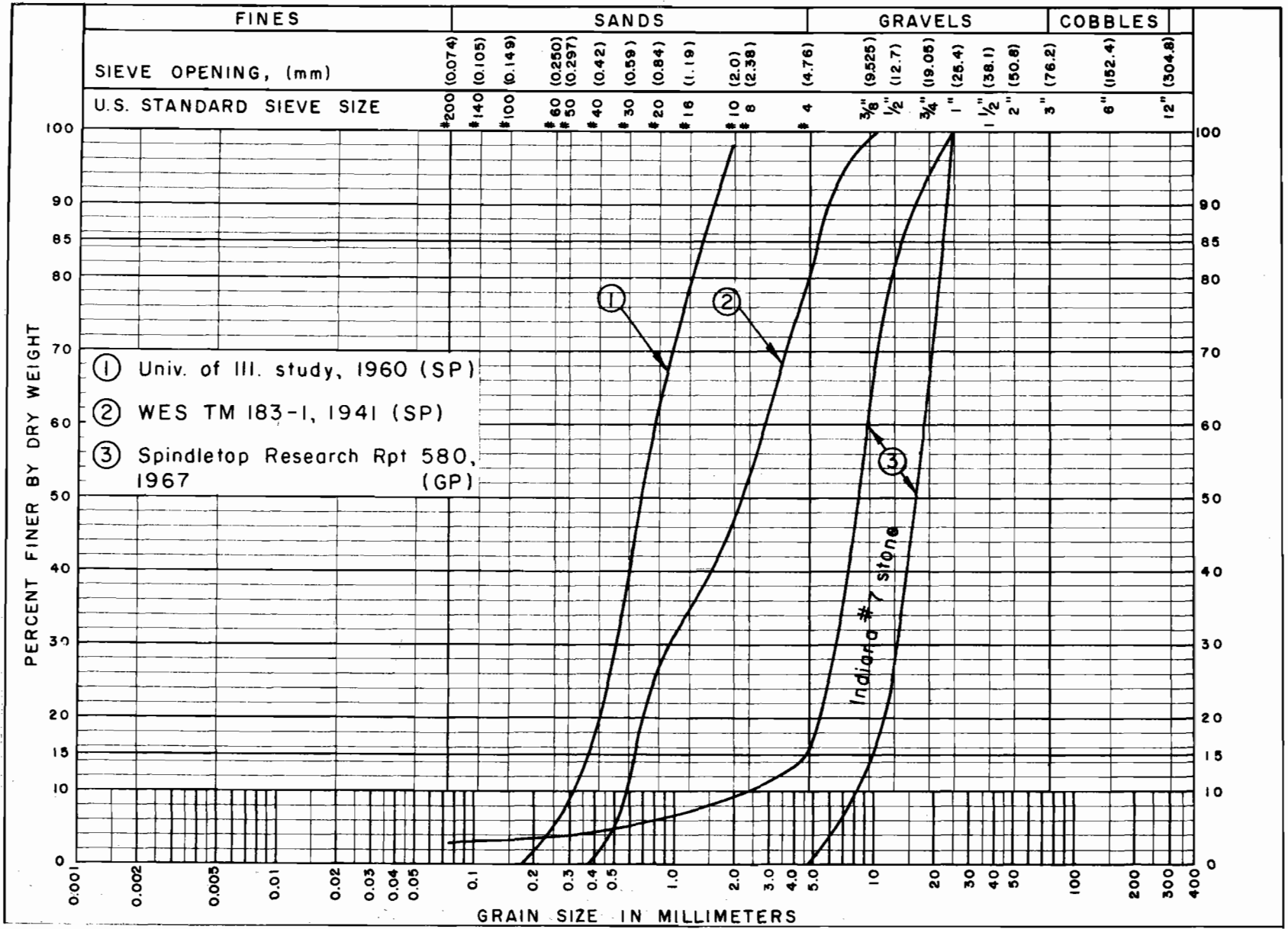

Considering that only a few studies are available for this type of review and that these are not complete in every aspect, any procedure developed for estimating discharge into perforated pipe must necessarily be conservative. The above studies show that sands are more restrictive to flow through small openings than gravels. Therefore, the development that follows is limited to pipes placed in gravel drain material meeting the requirements that: (1) it will be virtually clean, (2) it will have a coefficient of uniformity less than 3, and (3) it will have a median or D_{50} size equal to or greater than the perforation diameter or slot width. Area or discharge reductions are made for conservatism: 70% for circular perforations and 40% for rectangular slots.

The area (A) per foot of pipe is given in Figure A-3 for 1/4 in., 5/16 in., and 3/8 in. diameter perforations. Flow quantity (q in cfs.) per foot of pipe can be estimated from Figure A-4 for circular perforations and from Figure A-5 for rectangular slots. The maximum orifice head considered is 2.0 feet since it is preferred that the water surface be maintained within the gravel drain material.

The flow equation for Figures A-3 and A-4 is:

$$q = CA_e (2gh)^{1/2} \quad \text{where}$$

q = discharge in cfs. per foot length of pipe

C = orifice coefficient (0.6 for circular perforations and 0.67 for rectangular slots).

A_e = effective area of openings per foot length of pipe (0.3A for circular perforations and 0.6A for rectangular slots, A being the non-restricted area). This correction is to account for blockage of openings by sand and gravel particles.

Note: Computations for discharge quantity curves included a conversion from square inches to square feet.

h = head over the orifice in feet.

ES-97 of NEH Section 5, Hydraulics, is recommended for estimating flow conditions within the pipe.

When high design discharges are involved and multiple outlets are not practical, more than one perforated pipe may be used to satisfy either the inflow (orifice) condition or the pipe flow condition.

Circular Perforations

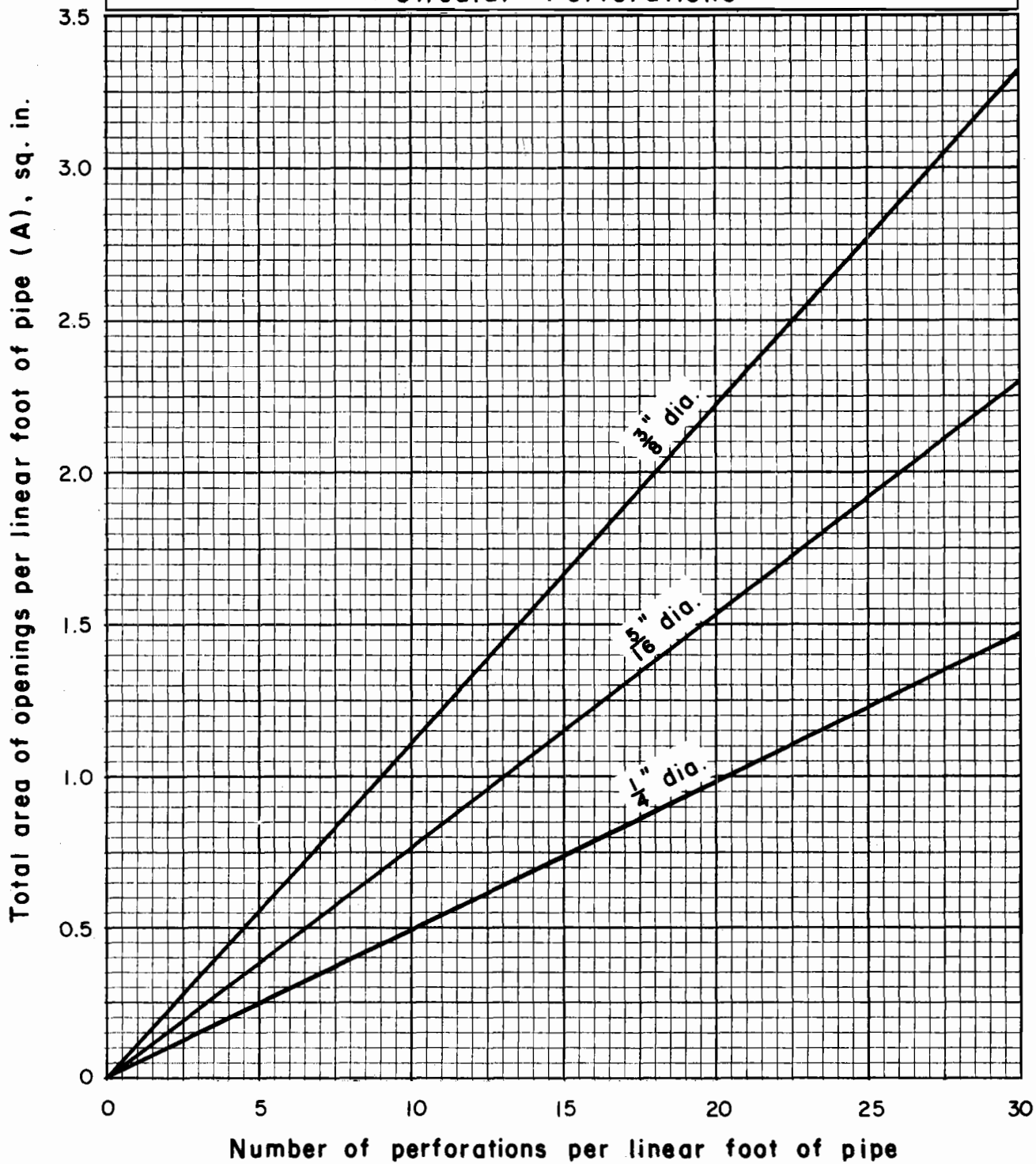

Figure A-3: Total area of circular perforations per foot length of pipe.

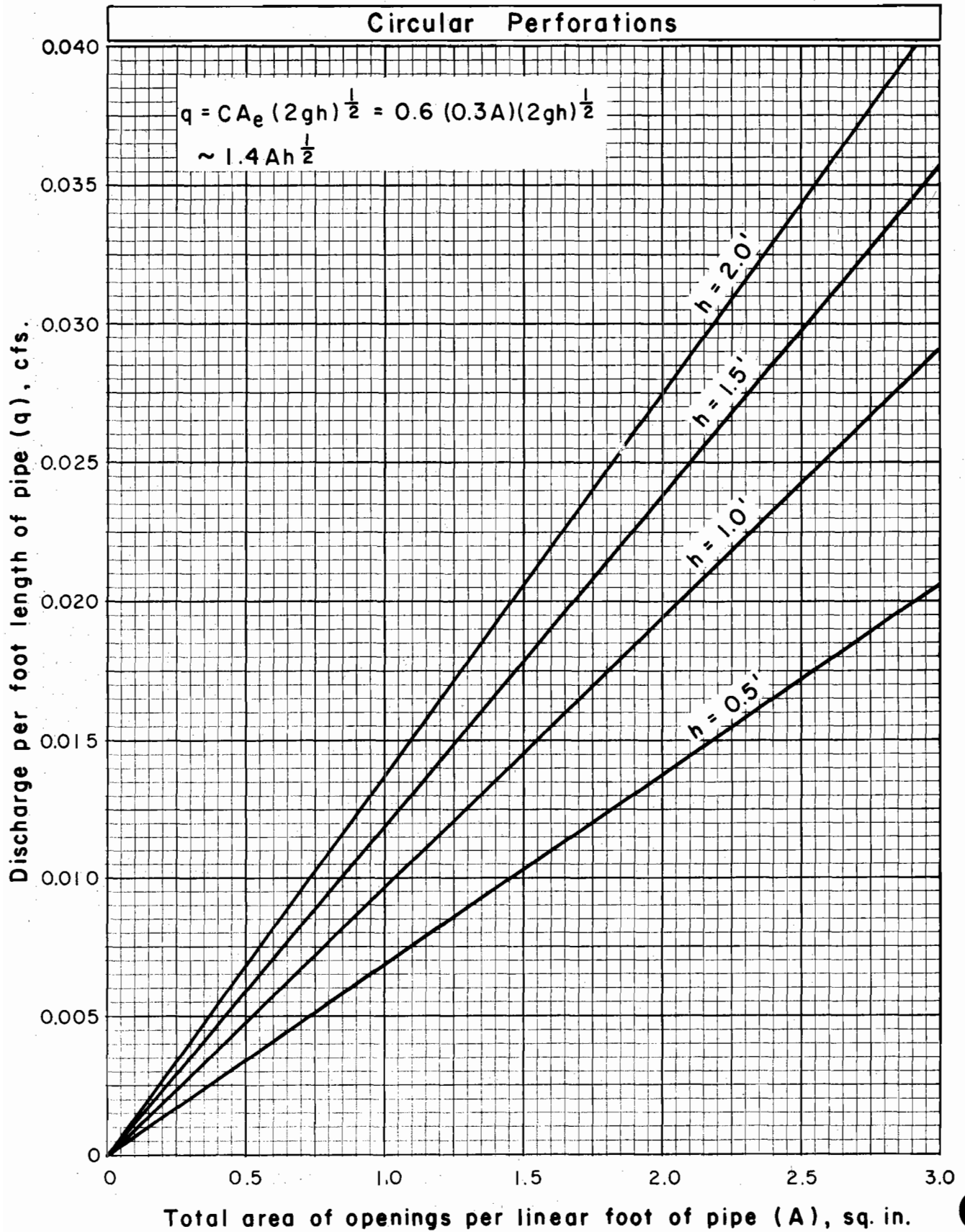

Figure A-4: Flow into pipe with circular perforations.

Rectangular Slots

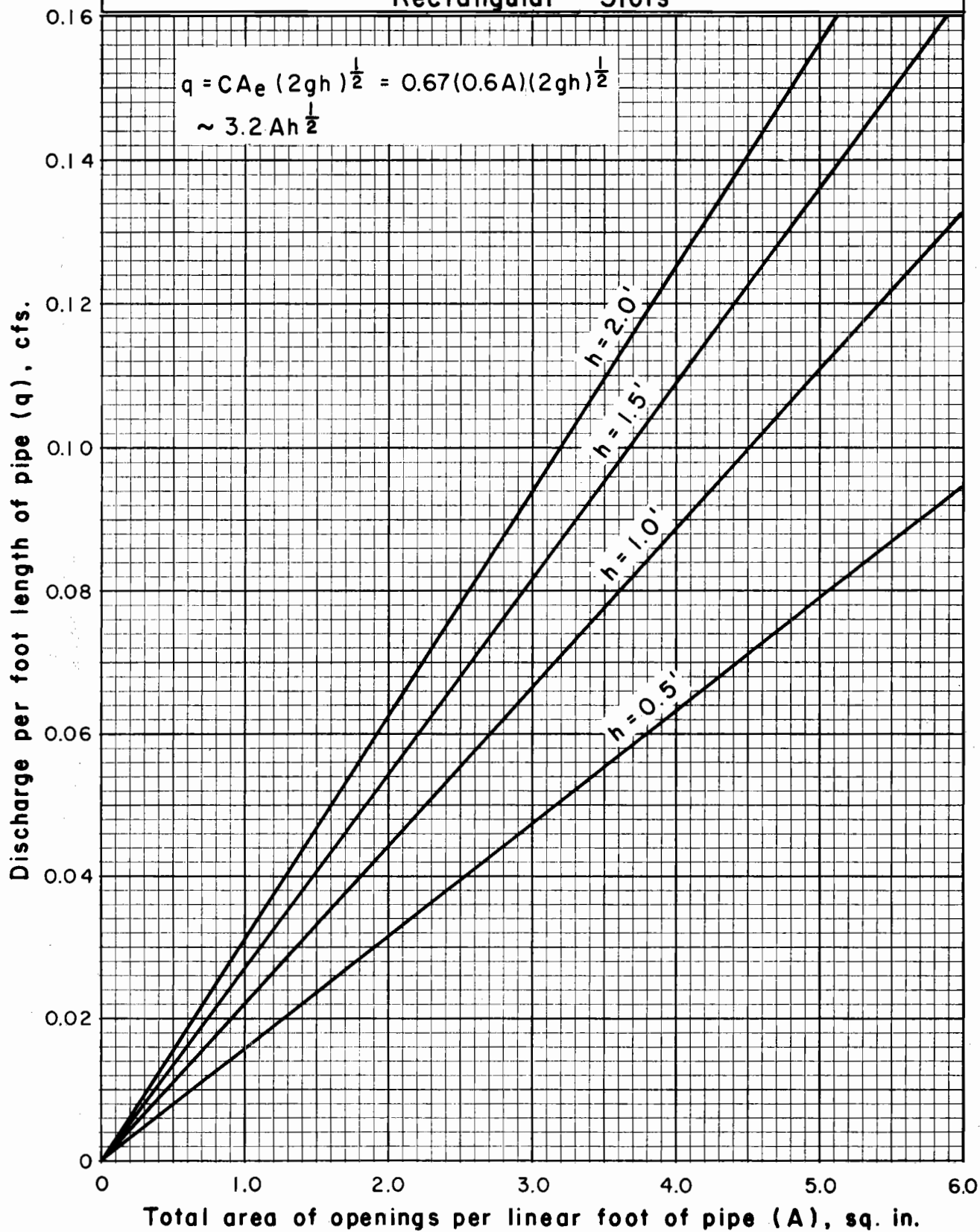

Figure A-5: Flow into pipe with rectangular slots.



Appendix B

Relief Wells

I. General

A simplified and approximate method for design of relief wells is given in this appendix. It is based on well formulae developed for confined or artesian aquifers that are homogeneous and isotropic. Refer to the work of C. I. Mansur and R. I. Kaufman as edited by G. A. Leonards in "Foundation Engineering", 1962, McGraw-Hill Book Company, Inc., page 281.

In this appendix, a blind well refers to a relief well which consists solely of either drain material or drain material and filter material, i.e. it has no well screen or pipe. A fully penetrating well is one in which the well extends entirely through the aquifer, whereas a partially penetrating well extends into the aquifer but not entirely through it.

Head lost in flow from the reservoir to the free outlet is divided into three parts: H , H_m , and H_w . Many symbols and definitions are given in Figure B-1; other symbols are defined where they are first used.

- A. H is the head loss in the aquifer to a point midway between wells.

$$H = h_e - h_m = \frac{Q_w}{k_f D} \left(\frac{L_e}{a} - 0.11 \right) \quad (\text{Eq. B-1a})$$

This is simplified by dropping the term 0.11.

$$H = \frac{Q_w L_e}{k_f D a} \quad (\text{Eq. B-1b})$$

This head loss depends upon the uplift pressure that can be tolerated midway between wells near the downstream toe of an embankment.

- B. H_m is the head loss in the aquifer from a point midway between wells to a well.

$$H_m = h_m - h_w = \frac{Q_w}{2\pi k_f D} \ln \left(\frac{a}{\pi r_w} \right) \quad (\text{Eq. B-2})$$

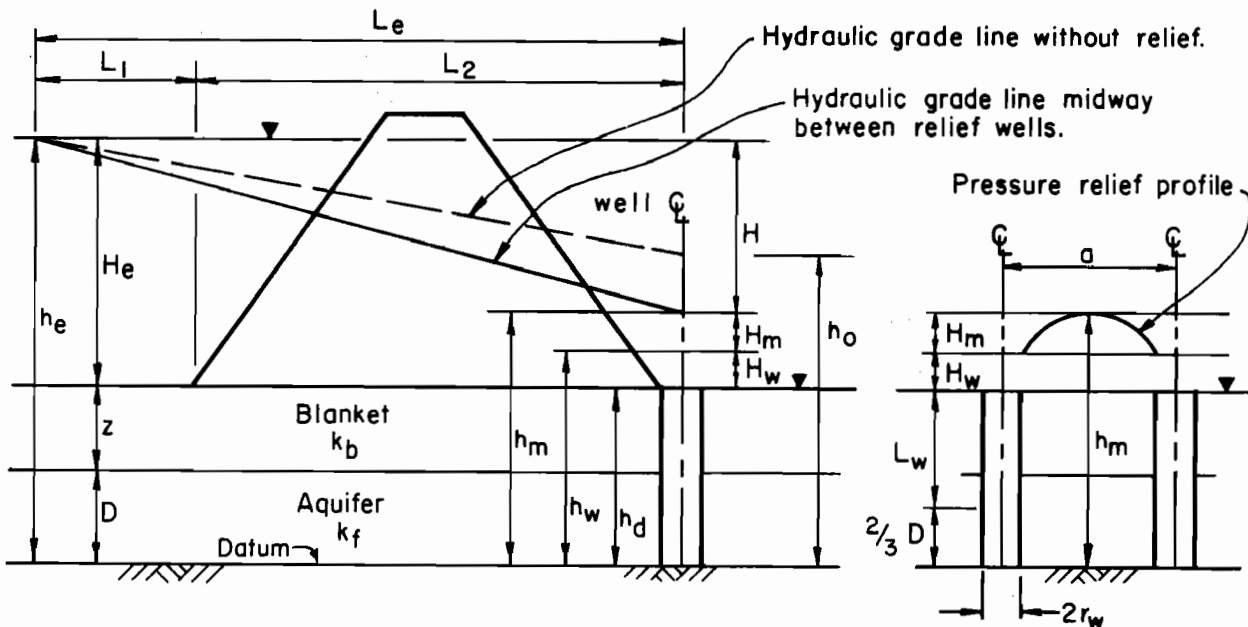

- A_w = cross sectional area of well pipe or well drain material
 a = spacing of wells
 D = thickness of aquifer
 H = $h_e - h_m$ = head loss associated with flow Q_w to h_m
 H_e = $h_e - h_d$ = potential head between reservoir water surface and well discharge height
 H_m = $h_m - h_w$ = head loss associated with flow Q_w between h_m and h_w
 H_w = $h_w - h_d$ = head loss associated with flow Q_w from each well
 h_e = height of reservoir water surface above datum
 h_d = height of well discharge above datum
 h_o = height of hydraulic grade line above datum at downstream toe of embankment without wells
 h_m = height of hydraulic grade line above datum at mid-point between installed flowing wells
 h_w = height of piezometric surface above datum at effective diameter of well
 k_b = permeability coefficient of blanket (vertical)
 k_f = permeability coefficient of aquifer (horizontal)
 k_w = permeability coefficient of drain material in well
 L_w = average vertical seepage length in well
 L_1 = effective length of upstream blanket
 L_2 = length of embankment base
 L_e = $L_1 + L_2$
 Q_w = quantity of flow to well
 $2r_c$ = diameter of inner well core or diameter of well pipe
 $2r_h$ = diameter of drill hole for well
 $2r_w$ = effective diameter of well
 z = thickness of blanket

Figure B-1. Relief well design, symbols

Substituting the expression for Q_w from Eq. B-1b into Eq. B-2 gives:

$$H_m = 0.3665a \left(\frac{H}{L_e} \right) \log_{10} \left(\frac{a}{\pi r_w} \right) \quad (\text{Eq. B-3})$$

Chart solutions of Eq. B-3 for fully penetrating wells having effective well diameters of 24, 20, 16, 12 and 10 inches are given in Figures B-2 through B-6 for various values of H/L_e and a .

Effective well diameter ($2r_w$) is defined as follows:

For well screen without filter (naturally developed filter),
 $2r_w$ = outside diameter of well screen ($2r_c$).

For well screen with filter, $2r_w$ = 0.5 (outside diameter of filter + diameter of well screen) = $0.5 (2r_h + 2r_c)$.

For blind well consisting of drain material only -- no filter,
 $2r_w$ = diameter of drain material ($2r_h$).

For blind well consisting of drain material and filter material, $2r_w$ = 0.5 (outside diameter filter + diameter of drain material) = $0.5 (2r_h + 2r_c)$.

C. H_w is the sum of all head losses in a well.

$$\text{For blind wells, } H_w = \frac{Q_w L_w}{k_w A_w} \quad (\text{Eq. B-4})$$

For wells with screens and riser pipe, H_w is the sum of screen losses, pipe friction, fitting losses, and velocity head.

The sum of H , H_m , and H_w equals the total net head, H_e , available for flow.

$$H_m + H_w = H_e - H$$

$$\text{From Figure B-1, } H_e - H = h_m - h_d$$

$$\therefore H_m + H_w = h_m - h_d \quad (\text{Eq. B-5})$$

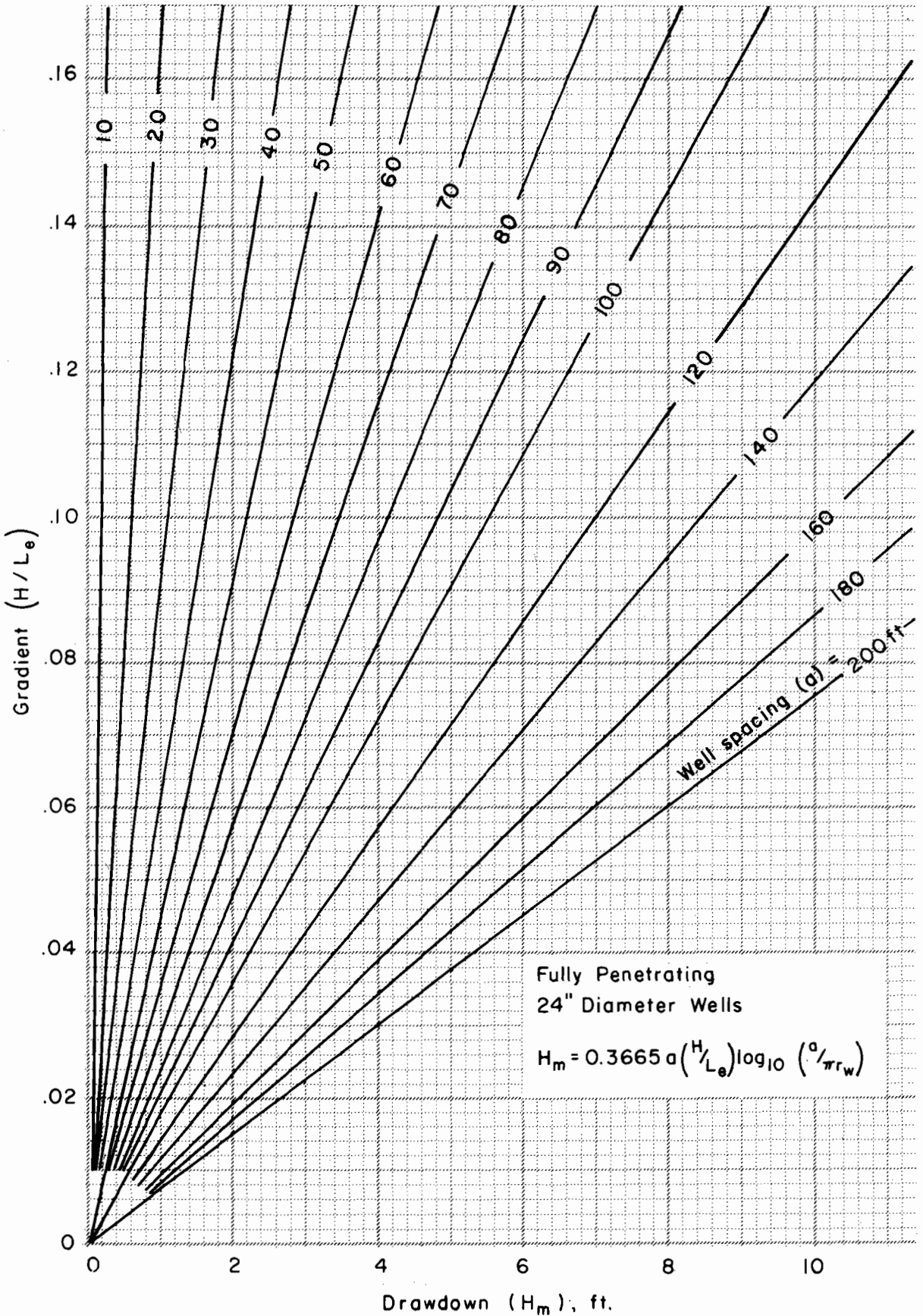

Figure B-2. Relief well design

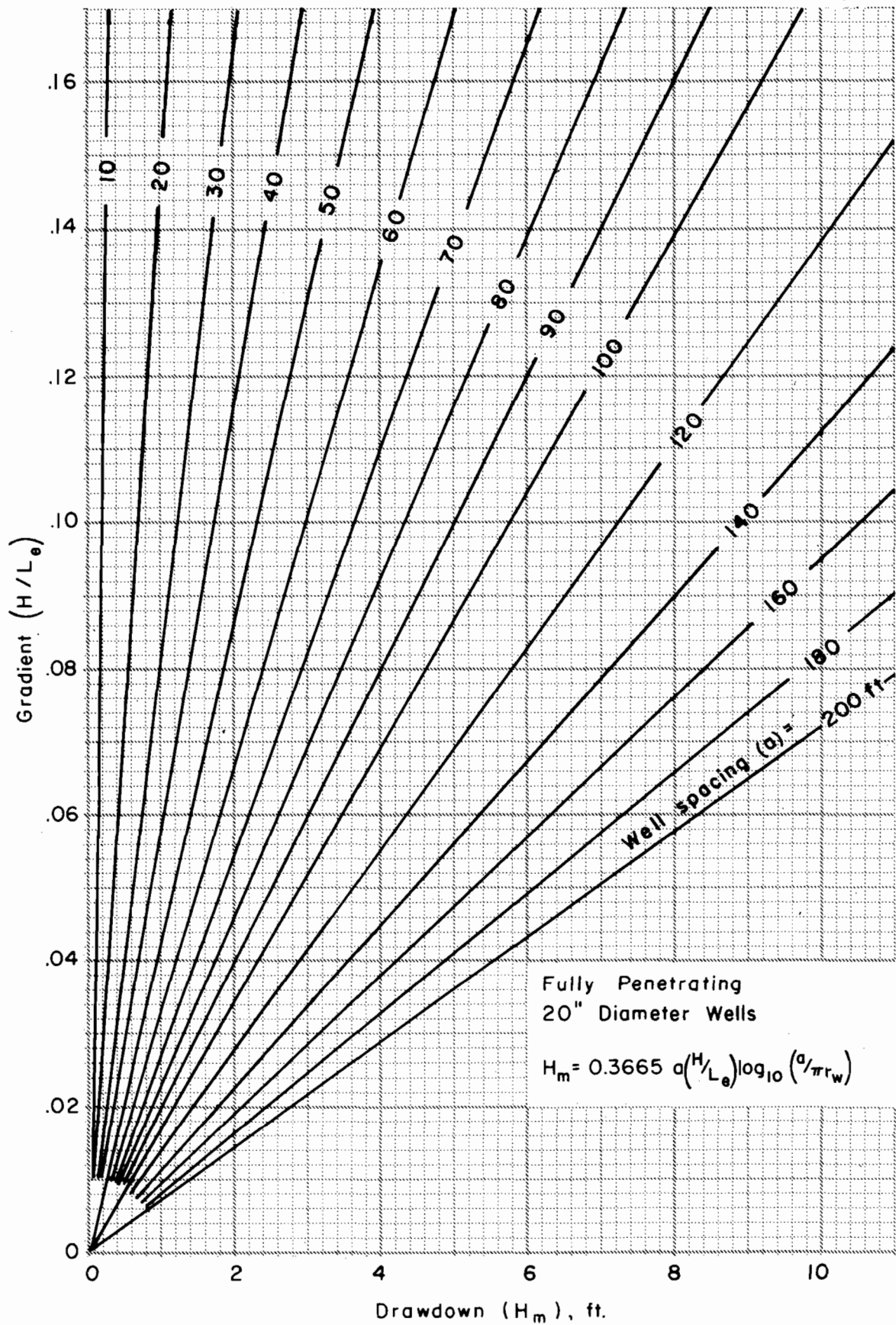

Figure B-3. Relief well design

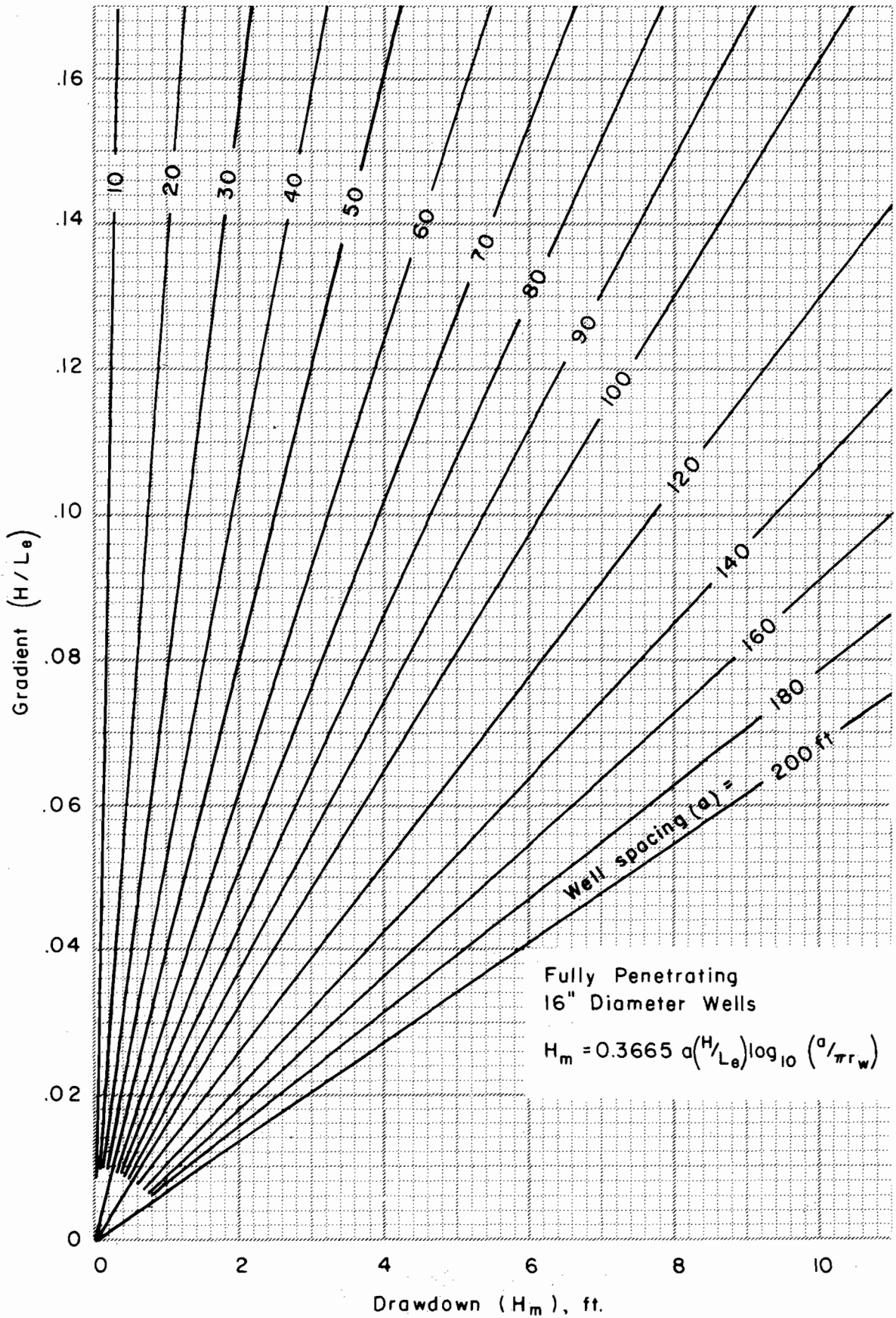

Figure B-4. Relief well design

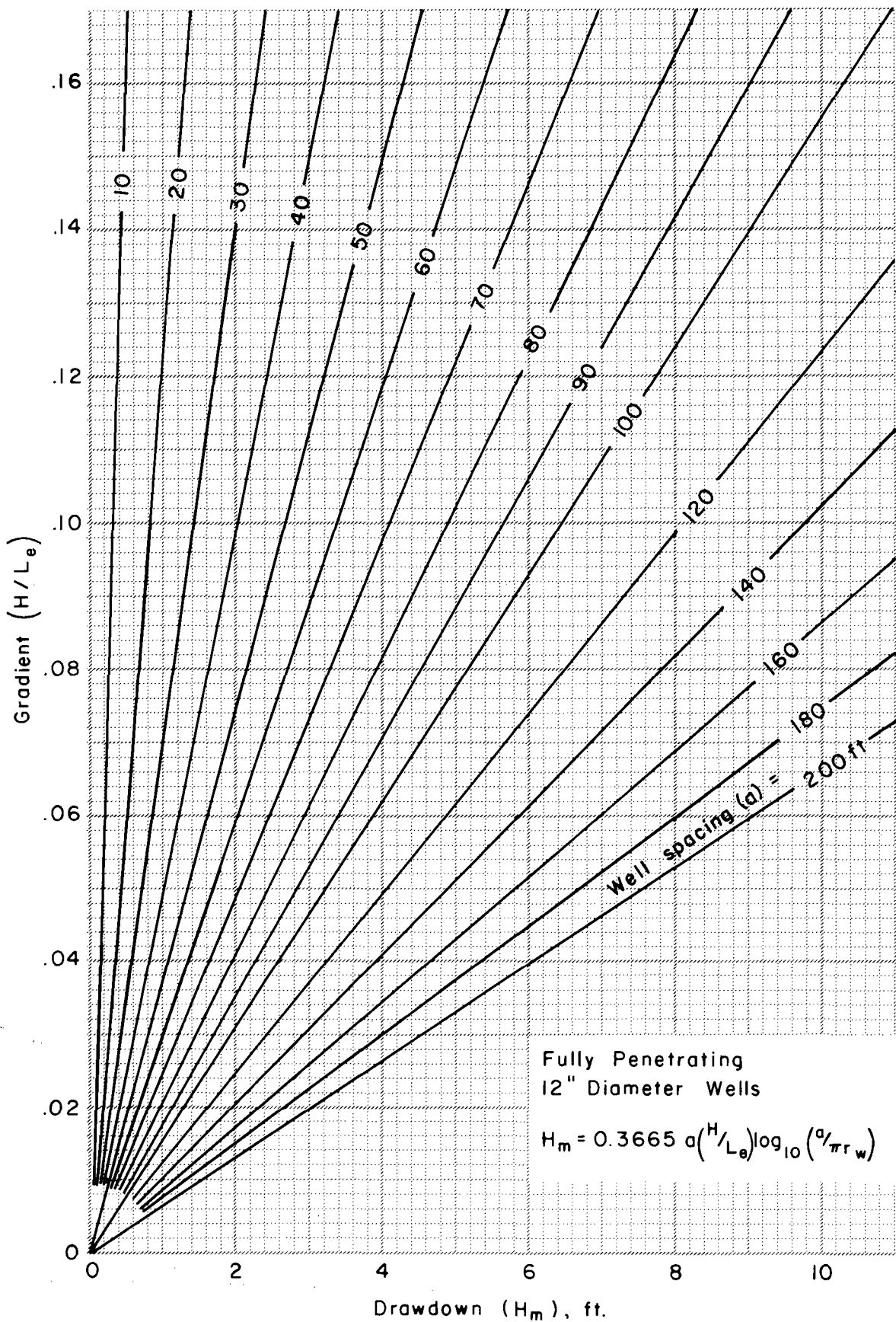

Figure B-5. Relief well design

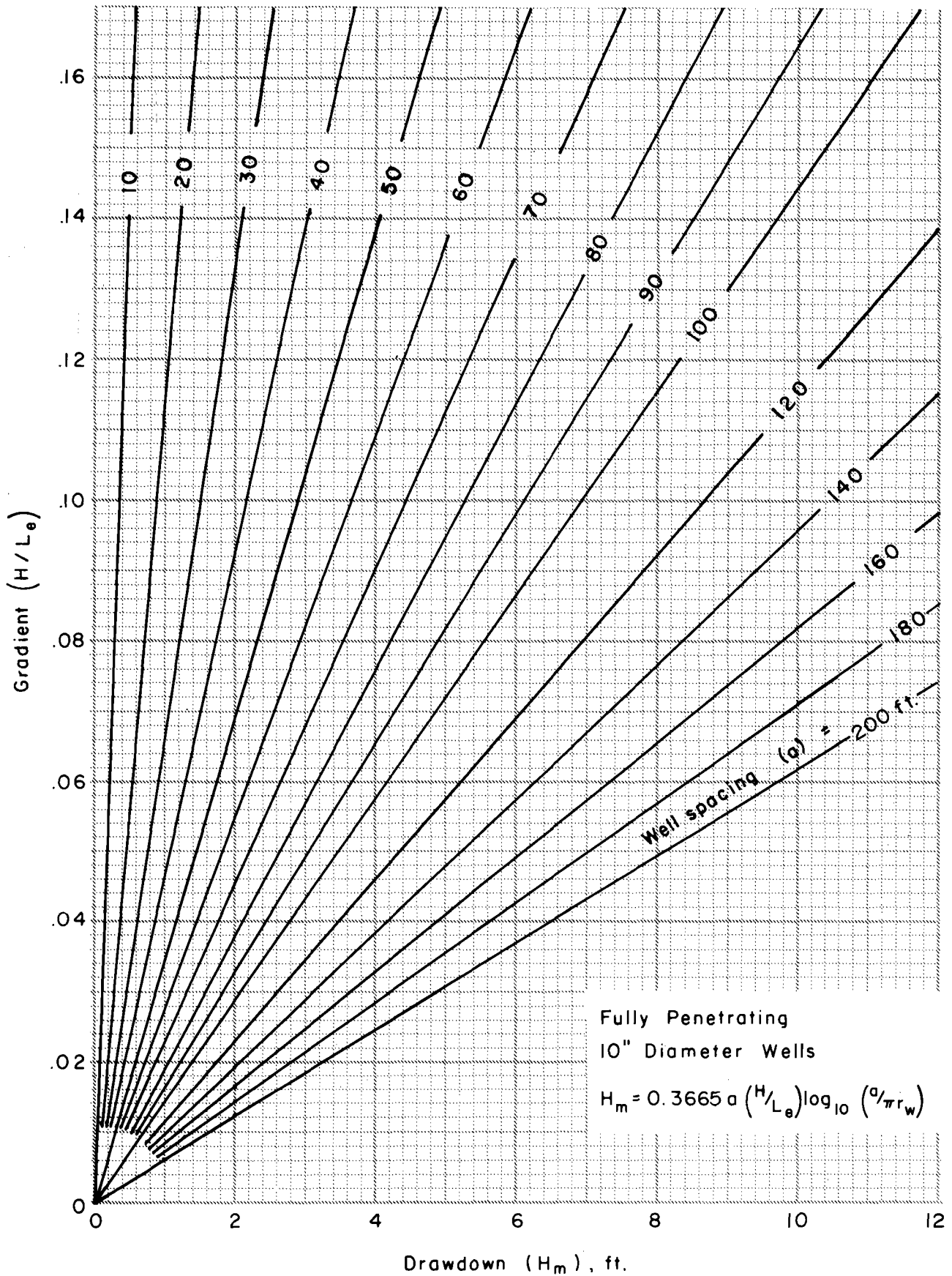

Figure B-6. Relief well design

II. Design Procedures

A. Fully penetrating blind wells

1. Determine $L_e = L_1 + L_2$, tolerable h_m , and $H = h_e - h_m$ from site conditions using methods similar to Bennett which are illustrated in the SM-10, Chapter 12, pages 12-19 through 12-21.

$$L_1 = \left[\frac{k_f}{k_b} zD \right]^{1/2} \quad (\text{Eq. B-6})$$

$$h_m \quad (\text{tolerable}) = \frac{z \gamma_{\text{sub}}}{F_h \gamma_w} + (z + D) \quad (\text{Eq. B-7})$$

where γ_{sub} = submerged unit weight of blanket material
 γ_w = unit weight of water
 F_h = factor of safety relative to heaving of blanket midway between wells (≥ 1.5)

2. Compute Q_w in terms of a from Eq. B-1b.
3. Compute L_w

$$L_w = h_d - \frac{2D}{3} \quad (\text{Eq. B-8})$$

4. Solve for H_w in terms of a , substituting Q_w from step 2 into Eq. B-4.
5. Plot the value for h_d as shown in Figure B-7.
6. For two assumed values of a , plot the straight line $h_w = (h_d + H_w)$ vs. a as shown in Figure B-7.
7. Plot the value for h_m as shown in Figure B-7. This may be the tolerable value from step 1 or a lesser value.
8. Determine values of H_m for various well spacings using the appropriate set of curves (Figures B-2 through B-6). Effective well diameter and ratio H/L_e are known.

Plot the curve $h_w = (h_m - H_m)$ vs. a as shown in Figure B-7.
9. The intersection of the two curves gives the well spacing at which Eq. B-5 ($H_m + H_w = h_m - h_d$) is satisfied.

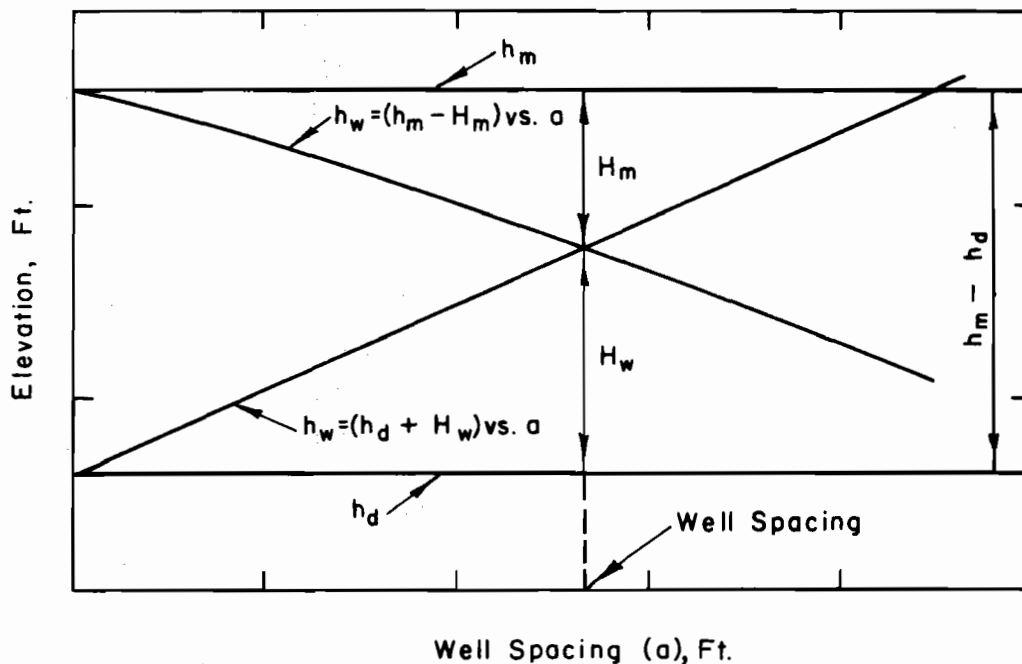

Figure B-7. Head loss vs. well spacing
(arithmetic scales)

10. Use of Darcy's law in Eq. B-4 for well loss, H_w , depends on the existence of laminar flow conditions in the well. Check this by plotting k_w vs. i_w in Figure B-8. If the plotted point falls outside the laminar region, adjust the well spacing, the discharge elevation, or the well diameter and re-do the previous steps.

An alternate to this requirement is developing, by test, a curve of unit discharge vs. gradient for the drain material to be used. From the known values of Q_w/A_w (Q_w in terms of a) and L_w , H_w can be determined from the test curve for various spacings, a , and entered into step 6. ($H_w = i_w L_w$)

B. Partially penetrating blind wells.

Where blind wells partially penetrate homogeneous and isotropic aquifers, the following equation is applicable. See "Groundwater and Seepage" by M. E. Harr, 1962, McGraw-Hill Book Co., page 263.

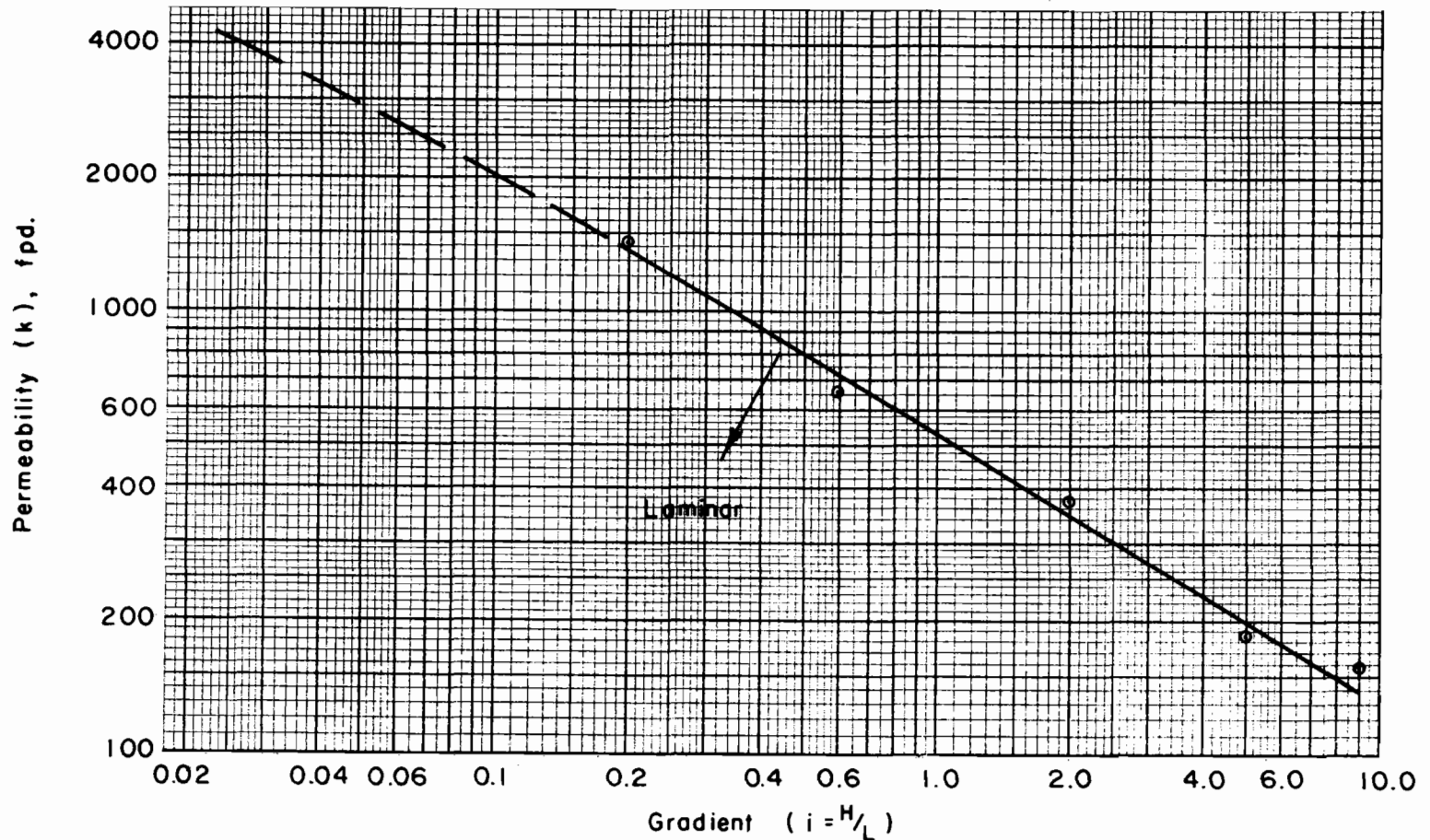

This chart, which defines a limiting velocity for laminar flow below which Darcy's law is valid, was developed from data of Table 3, p. 256, vol. 26, No. 12, Public Roads, "Highway Subdrainage," by Barber and Sawyer.

More reliable permeability rates can be determined by making permeability tests of the specified drainage material at the designed gradient.

Figure B-8. Limiting gradient for laminar flow at various k values

$$G = \frac{w}{D} \left| 1 + 7 \left(\frac{r_w}{2w} \right)^{1/2} \cos \left(\frac{\pi w}{2D} \right) \right| \quad (\text{Eq. B-9})$$

where w = depth of penetration of well into aquifer and

G = the ratio $\frac{Q \text{ partially penetrating}}{Q \text{ fully penetrating}}$ for the same value of H_m

Figure B-9 is a solution of this equation.

The procedure is the same as for fully penetrating blind wells except that L_w is computed by Eq. B-10 below and the points $h_w = h_m - H_m$ are plotted vs. Ga , a being the spacing determined for full penetration. The intersection of $(h_d + H_w)$ vs. a and $(h_m - H_m)$ vs. Ga gives the spacing corrected for partial penetration.

$$L_w = h_d - (D - w) \quad (\text{Eq. B-10})$$

C. Fully penetrating wells with screens and riser pipe.

The procedure is the same as for fully penetrating blind wells except that well loss, H_w , is determined by summation of screen loss, pipe friction loss, fitting or coupling losses, and velocity head loss.

1. Screen loss. It has been determined by test and experience that screen friction loss can be neglected if the entrance velocity is 0.1 fps or less. Refer to "Ground Water and Wells", 1966, Edward E. Johnson, Inc., page 193.

Estimate the entrance velocity by dividing Q_w by 0.6 of the unclogged area of the screen. The 0.6 factor is introduced for this estimate similar to the requirement suggested for rectangular slotted pipe in Appendix A. Most screen manufacturers will provide information on the total opening area for their various screens.

2. Pipe friction loss, H_f , may be estimated from Figure B-10. When Hazen-Williams roughness coefficient (C) = 100, obtain friction head loss in 100 feet of well pipe (H_{f100}) directly from Figure B-10. Then, friction loss for actual length of pipe (H_f) = $(L_w/100)(H_{f100})$. When C has a value other than 100, use line in upper right-hand corner of Figure B-10 to obtain factor F . Then, friction loss in actual length of well pipe (H_{fc}) = $(L_w/100)(H_{f100})(F)$. Other methods of determining H_f are presented in SCS NEH Section 5, Hydraulics.
3. Velocity head loss, H_v , may be estimated from Figure B-11.

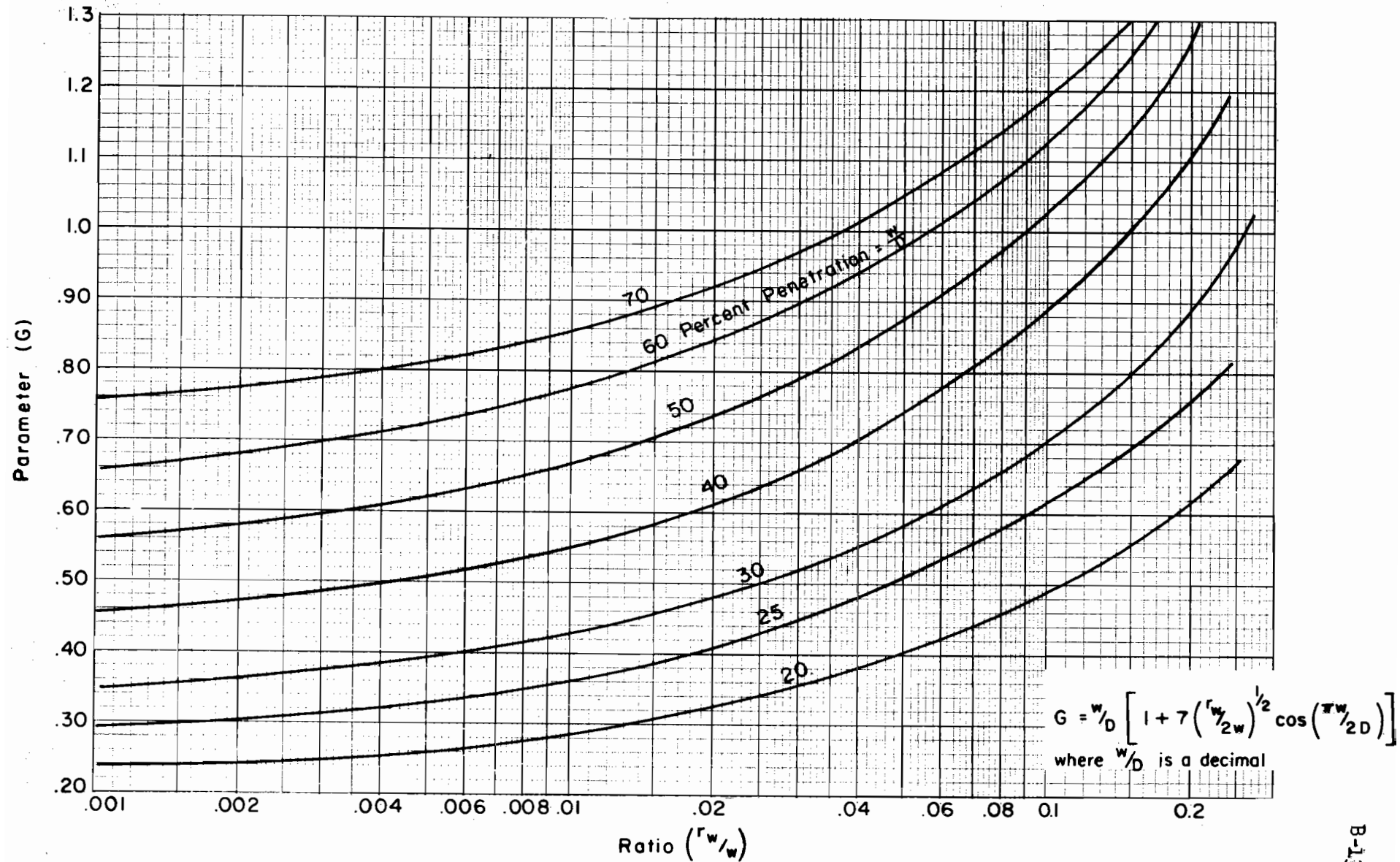

Figure B-9. Parameter G vs. r_w/w and percent penetration for partially penetrating wells with open bottom

Hazen-Williams roughness coefficient (C)

Friction Loss per 100 feet of pipe for Hazen-Williams C = 100, Ft.

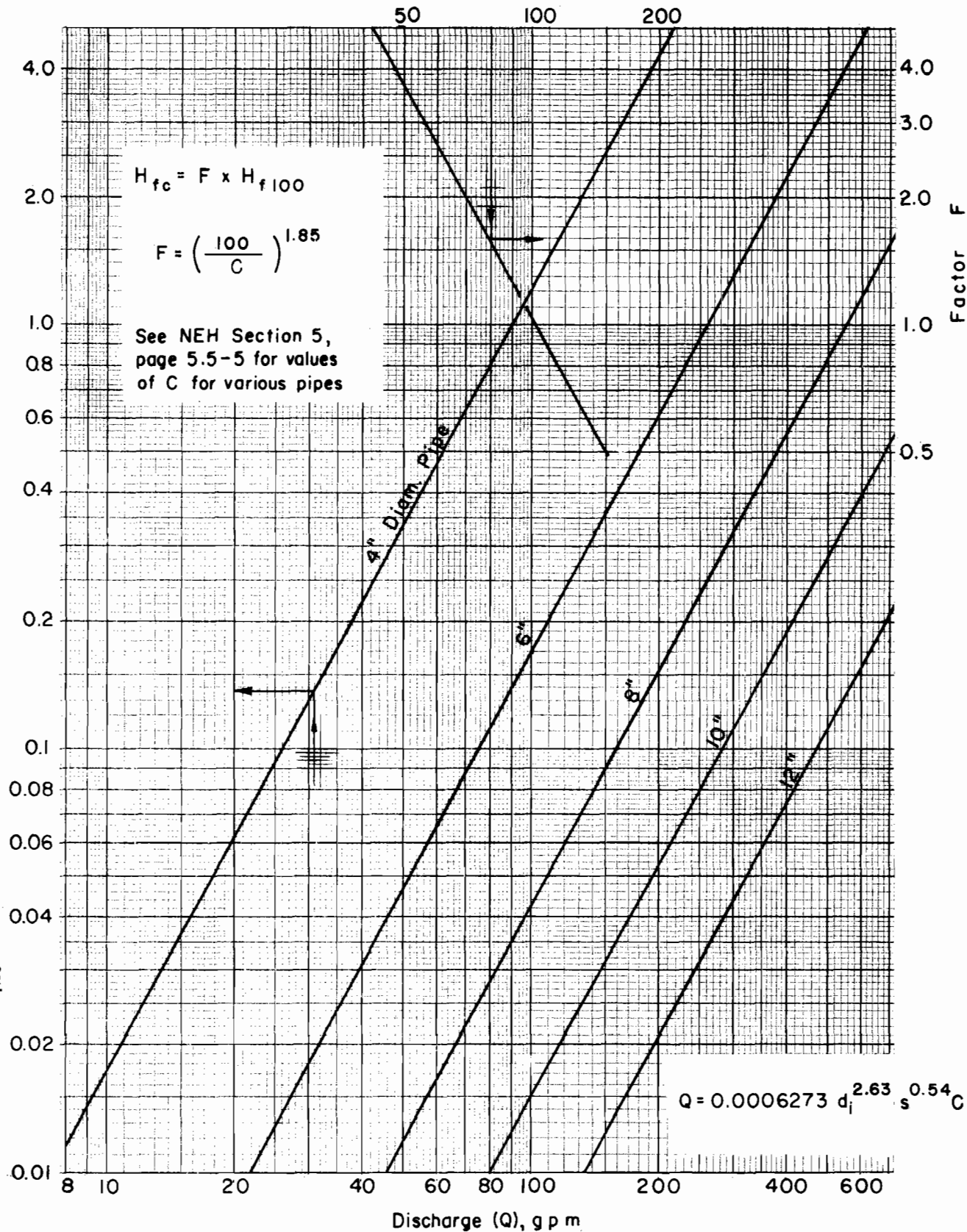

Figure B-10. Friction head loss for pipe

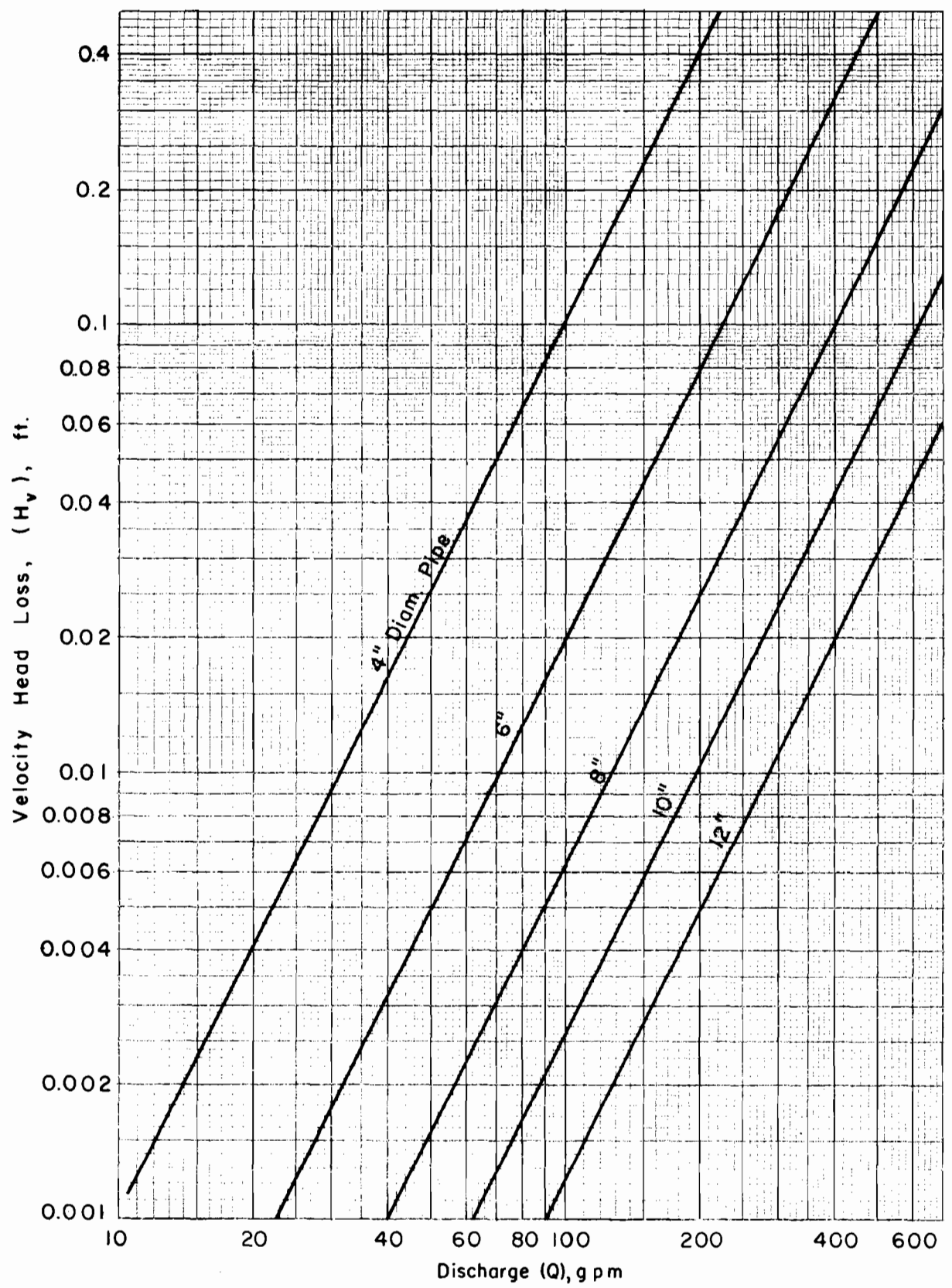

Figure B-11. Velocity head loss

4. Multiply the number of connections by $1.5 H_v$ to determine connection losses, H_x .

An alternate to this method is given in the Corps of Engineers, EM-1110-2-1903, 1963.

- D. Partially penetrating wells with screen and riser pipe.

It is recommended that procedures outlined in the Corps of Engineers EM 1110-2-1903, 1963, be used.

III. Application notes

- A. The formulae presented apply to confined aquifers that are essentially homogeneous and isotropic. Aquifers are generally stratified, making it necessary to transform layer thicknesses and permeabilities to an equivalent isotropic section before entering the formulae. An excellent discussion of stratified aquifers and transformation is made by W. J. Turnbull and C. I. Mansur, "Relief Well Systems for Dams and Levees", ASCE Transactions, Vol. 119, 1954, pages 842-878, and in the accompanying discussion by P. T. Bennett.
- B. Filter and drain material must meet gradation requirements for prevention of piping.
- C. It is suggested that screen slot width be the same as or smaller than the D_{50} size of surrounding drain material.

Reference List

1. Barber, E. S., and Sawyer, C. L., "Highway Subdrainage", Public Roads, Vol.26, No. 12, 1962.
2. Bennett, P. T., "The Effect of Blankets on Seepage Through Pervious Foundations", ASCE Transactions, Vol. 111, 1946.
3. Casagrande, A., "Seepage Through Dams", Contributions to Soil Mechanics, Boston Society of Civil Engineers, 1925-1940.
4. Cedergren, H. R., Seepage, Drainage, and Flow Nets, 1967, John Wiley and Sons, Inc.
5. Corps of Engineers, "Design of Finite Relief Well Systems", EM 1110-2-1905, 1963.
6. Corps of Engineers, "Laboratory Tests of Relief Well Filters", Report 1, WES MP 5-68-4, 1968.
7. Corps of Engineers, "Investigation of Filter Requirements for Under-drains", WES TM 183-1, 1941.
8. Gillou, J. C., "First Progress Report on Performance of Filter Materials", University of Illinois, 1960.
9. Ground Water and Wells, 1966, Edward E. Johnson, Inc.
10. Harr, M. E., Groundwater and Seepage, 1962, McGraw-Hill Book Company, Inc.
11. Mansur, C. I., and Kaufman, R. I., "Dewatering", Edited by Leonards, G. A., Foundation Engineering, 1962, McGraw-Hill Book Company, Inc.
12. Spindletop Research, Report 580, "A Comparison of Flow Properties of Perforated Clay Pipe and Plain Drain Tile in Subsurface Drainage", 1967.
13. Sherard, J. L., et al, Earth and Earth Rock Dams, 1963, John Wiley and Sons, Inc.
14. Turnbull, W. J., and Mansur, C. I., "Relief Well Systems for Dams and Levees", ASCE Transactions, Vol. 119, Paper 2701, 1954.
15. USDA, Soil Conservation Service, "Basic Soil Mechanics", SM-10 Manual, 1966.
16. USDA, Soil Conservation Service, National Engineering Handbook, Section 5, "Hydraulics".



Appendix C

Appendix C contains examples for the various drain types discussed.



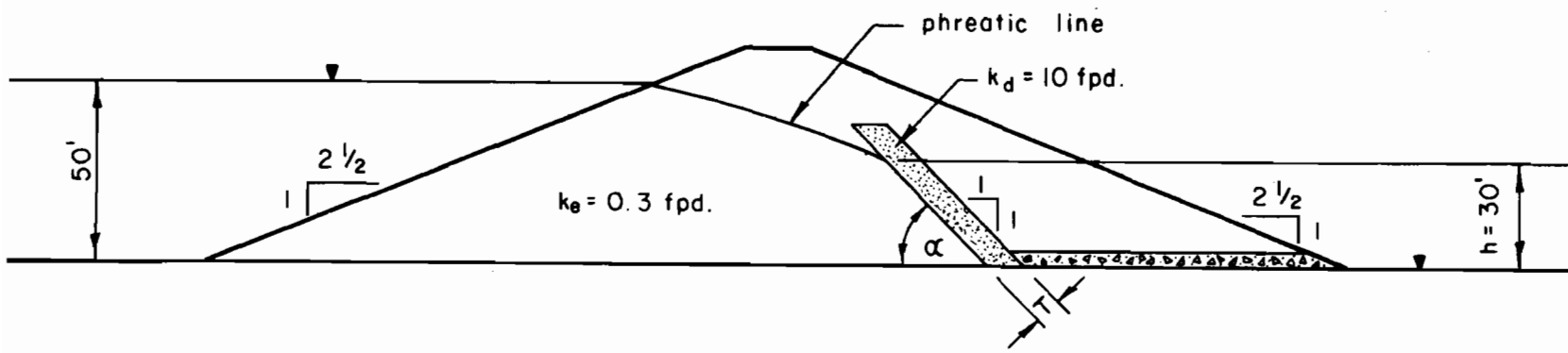

Determine horizontal thickness of sloping embankment drain using Figure No. 1, Sec. IV, A. Outlet is adequate.

1. Locate egress point of phreatic line by flow net or A. Casagrande's methods (pages 12-6 through 12-10, SM-10, Basic Soil Mechanics, 1966). $h = 30$ ft.
2. $\frac{k_d}{k_e} = 33$, $s = 1$ and $\frac{h}{T} = 48$ (Figure 1, page 6)
 $T = h/48 = 30/48 = 0.63$ ft.
3. Horizontal thickness = $T/\sin \alpha = 0.63/0.707 = 0.9$ ft.
4. Use horizontal thickness compatible with considerations such as construction methods, anticipated movements, etc., and adjust either the thickness or k_d to provide a reasonable margin of safety, e.g.:

Horizontal thickness	k_d
10 ft.	10 fpd.
5 ft.	20 fpd.

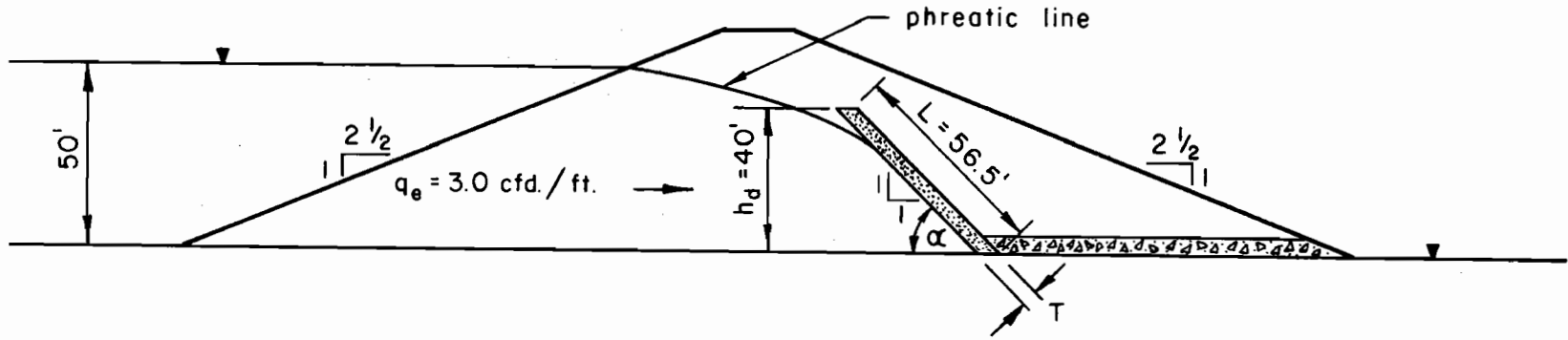

Determine permeability, k_d , required for the sloping embankment drain which has a horizontal thickness of 5 ft. Outlet is adequate. Use Darcy's law.

1. Estimated design discharge is 30 cfd./ft. length of dam. (10 times q_e)
2. $T = 5 \sin \alpha = 5 \times 0.707 = 3.5$ ft.
3. $q_d = k_d i A$ where

$$i = h/L = 40/56.5 = 0.7$$

$$A = T \times 1.0 = 3.5 \text{ sq. ft.}$$
4. $k_d = q_d/iA = 30/(0.7 \times 3.5) = 12$ fpd.
5. Select a drain material with permeability in the range of 10 to 50 fpd.

Example C-2: Sloping embankment drain (embankment not susceptible to cracking).

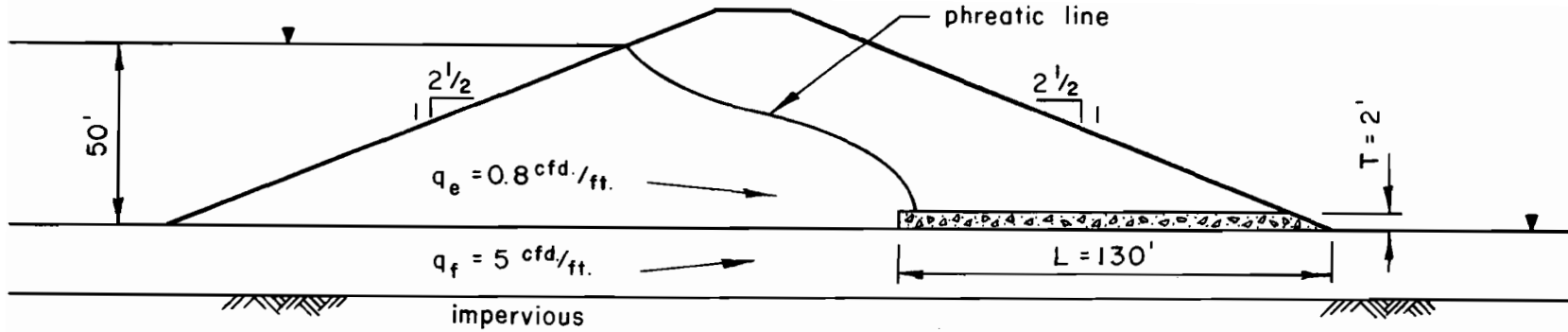

Determine the required permeability of the blanket drain, assuming that outlet at the toe is adequate.

1. Design discharge = $(0.8 + 5)10 = 58 \text{ cfd.}$ (10 times $q_e + q_f$)

2. $q_d = k_d i A$ where

$$i = \frac{h}{L} = \frac{T}{L} \quad (\text{available head} = \text{blanket thickness})$$

$$A = T \times l$$

$$q_d = k_d \frac{T^2}{L}$$

3. $k_d = \frac{(q_d)(L)}{T^2} = \frac{58 \times 130}{4} = 1900 \text{ fpd.}$

4. Select drain fill with k_d in the range of 2000 fpd.

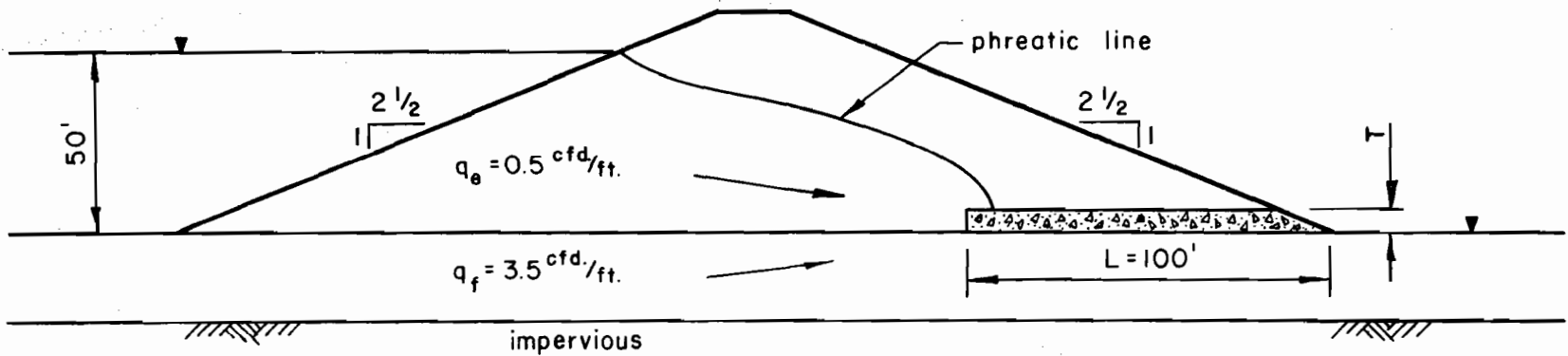

Determine required thickness of blanket drain with $k_d = 10$ fpd. and outlet at the toe is adequate.

1. Design discharge = 40 cfd./ft. (10 times $q_e + q_f$)

$$2. \quad q_d = k_d \frac{T^2}{L}, \quad T^2 = \frac{q_d L}{k_d}$$

$$T^2 = \frac{40 \times 100}{10} = 400$$

$T = 20$ ft. (too thick)

3. Try $k_d = 100$ fpd.

$$T^2 = \frac{40 \times 100}{100} = 40$$

$T = 6.3$ ft. (too thick)

4. Try $k_d = 1000$ fpd.

$$T^2 = \frac{40 \times 100}{1000} = 4$$

$$T = 2 \text{ ft.}$$

5. Use $T = 2$ ft. and k_d in the range of 1000 to 2000 fpd.

Example C-5. Blanket drain.

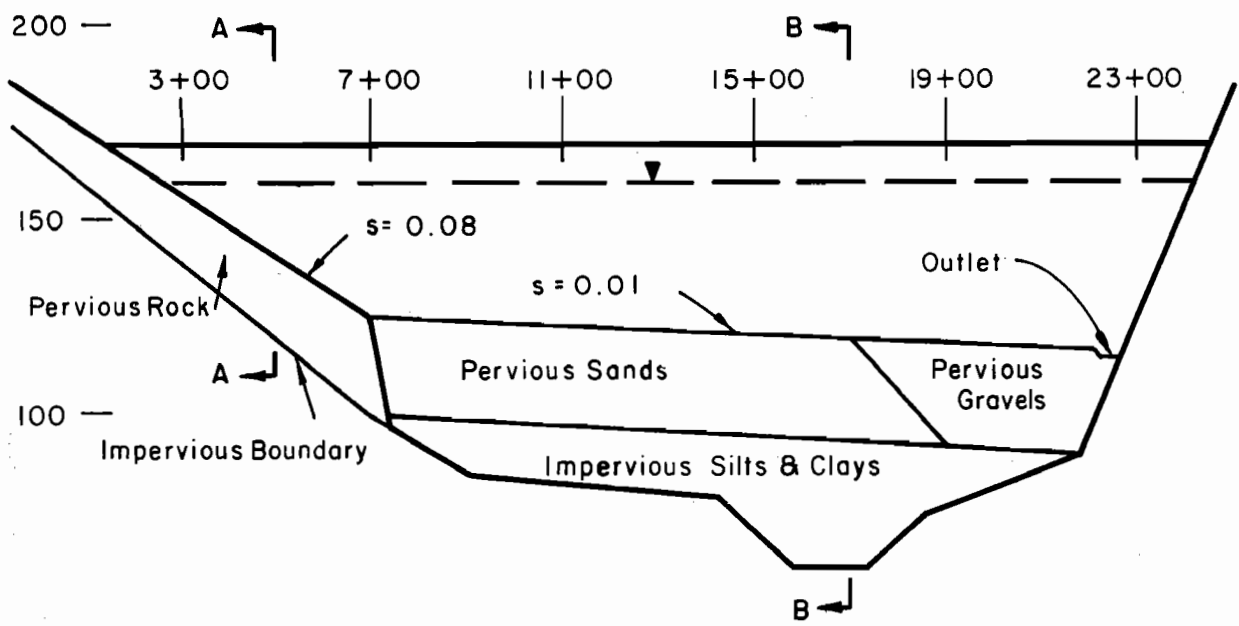

Figure (a). Drain Profile

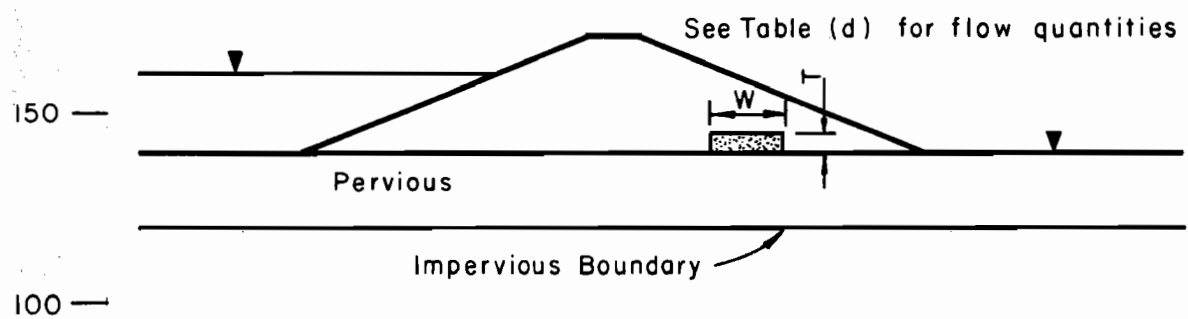

Figure (b). Section A-A

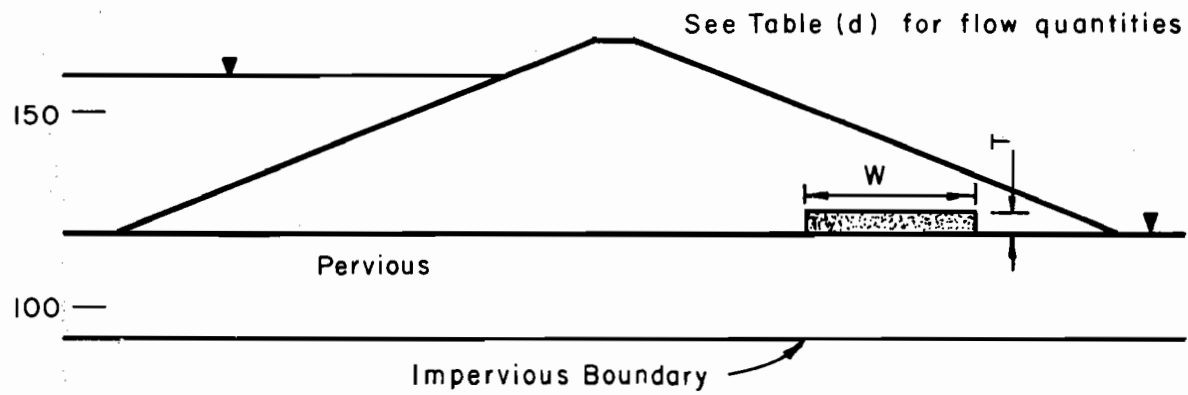

Figure (c). Section B-B

Example C-5 (continued)

Table (d). Flow quantities

Sta.	Dist. ft.	q_e cfd.	q_f per foot	q_{e+f}	q_{e+f} per reach cfd.	q_{e+f} accum. cfd.
3+00		0	2.0	2.0		-
5+00	200	0.1	20.0	20.1	2210	2210
7+00	200	0.3	40.0	40.3	6040	8250
7+00		0.3	1.0	1.3		8250
11+00	400	0.3	1.0	1.3	520	8770
15+00	400	0.3	1.0	1.3	520	9290
19+00	400	0.3	2.0	2.3	720	10010
22+20	320	0.3	2.0	2.3	736	10746

Proportion the blanket drain for the left abutment and flood plain. Permeability of available drain fill is 10,000 fpd. Assume that gradient, i , is approximately that of the ground surface, s . All flow is carried across the flood plain to the outlet near Sta. 22+20.

$$\text{Use } q_d = k_d i A$$

$$A = \frac{q_d}{k_d i}$$

Select a reasonable thickness, T , and determine width, W .

$$A = TW$$

Example C-5 (continued)

Table (e). Computations

Sta.	design discharge accum.* (cfd.)	k_{di}	A sq. ft.	T (assumed) ft.	W ft.	use
3+00	-	800	-	1.0		(15)
5+00	22100	800	28	2.0	14.0	(15)
7+00	82500	800	103	3.0	34.0	(35)
<hr/>						
7+00	82500	100	825	4.0	206	
11+00	87700	100	877	4.0	219	
15+00	92900	100	929	4.0	232	
19+00	100100	100	1001	4.0	250	
22+20	107460	100	1075	4.0	269	

Widths from Sta. 7+00 to 22+20 are not reasonable.

Try separate outlet for left abutment. T and W between Sta. 3+00 and 7+00 same as above.

7+00	-	100	-	2.0		use (10)
11+00	5200	100	52	2.0	26	(25)
15+00	10400	100	104	3.0	34.7	(35)
19+00	17600	100	176	4.0	44.0	(45)
22+20	24960	100	250	5.0	50	(50)

See Figure (f) for general layout of this drain.

Other dimensions may be more practical depending on conditions. For instance, width of the abutment portion may need to be large to contact wide spaced bedrock fractures. An additional outlet could be provided to divide flow in the flood plain area.

*(10 times estimated seepage quantities)

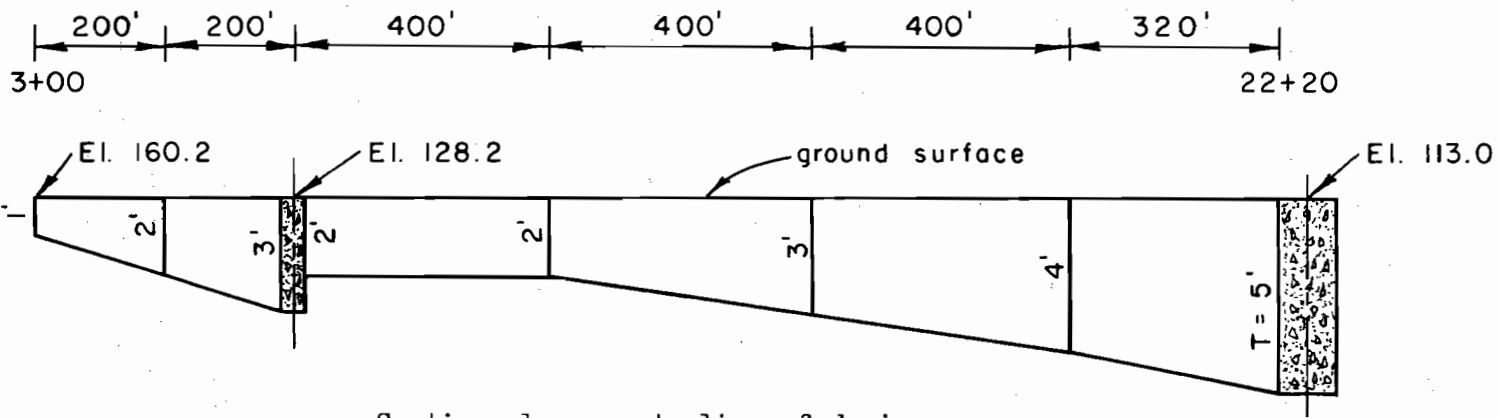

Section along centerline of drain
(Not to scale)

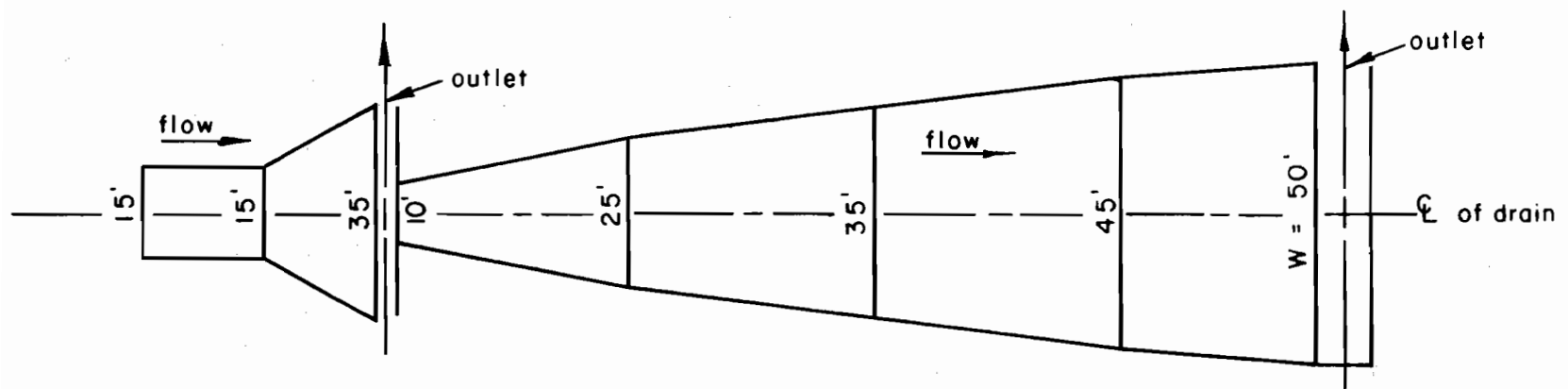

Plan
(Not to scale)

Figure (f). Dimensions of blanket drain.

Example C-6: Foundation trench drain
without pipe.

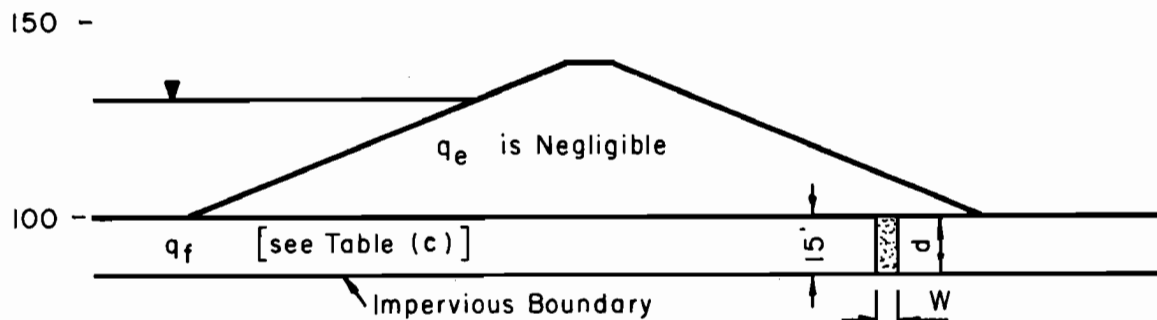
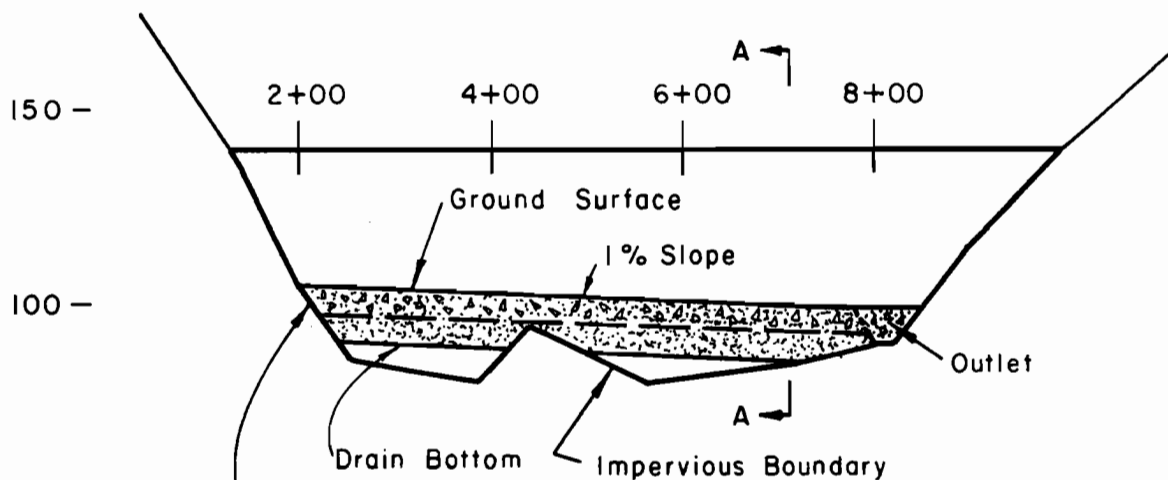

Figure (a). Section A-A.



Drain depth of 15' intercepts stratified materials.
Assume that depth available for flow to the outlet is
7' because of the impervious ridge at sta. 4+40.

Figure (b). Drain profile.

Table (c). Seepage quantities.

Sta.	Dist. ft.	cf. d./ft.	cf. d. per reach	cf. d. accum.
2 + 00				-
4 + 40	240	0.8	192	192
8 + 00	360	0.4	144	336

Example C-6 (continued)

Outlet is adequate. Proportion the drain.

1. A filter is needed to prevent migration of base material. Available sand was tested. The coefficient of permeability is 200 fpd. and gradation meets filter requirements.

Sta. 4+40: $q_d = kiA = 1920$ cfd. (the design discharge)

$$A = \frac{q_d}{ki} = \frac{1920}{200 \times 0.01} = 960 \text{ sq. ft.}$$

$$\text{since } d = 7 \text{ ft., } W = \frac{960}{7} = 137 \text{ ft.}$$

It is not practical to use the available sand for drain material.

2. Find k required for a drain width of 8 ft. at Sta. 8+00.
($A = 7 \times 8 = 56$ sq. ft.) $q_d = 3360$ cfd. (the design discharge)

$$k = \frac{q_d}{iA} = \frac{3360}{0.01 \times 56} = 6000 \text{ fpd.}$$

3. Find drain width at Sta. 4+40 with $k = 6000$ fpd.

$$A = \frac{q_d}{ki} = \frac{1920}{6000 \times 0.01} = 32 \text{ sq. ft.}$$

$$W = \frac{32}{7} = 4.6 \text{ (use 5 ft.)}$$

4. Gradation of available gravel is compatible with that of the filter sand and has a coefficient of permeability of 10,000 fpd. Proportion as shown in Fig. (d).

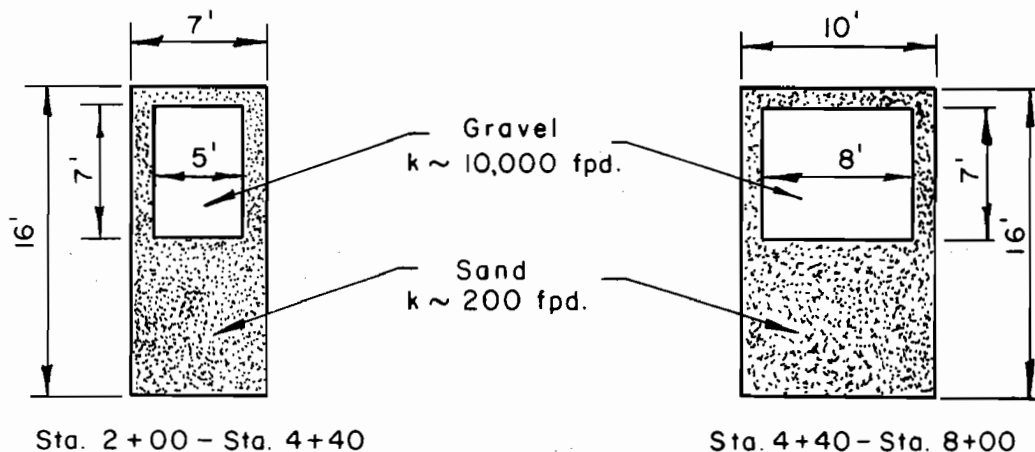

Figure (d). Drain dimensions.

Example C-6 (continued)

Note: Depth increased to 16' to provide space for
1 ft. of filter material over the drain material.

5. Alternates:

- a. Increase flow depth approximately 4 ft. by excavating through the impervious ridge at Sta. 4+40 to reduce width.
- b. Use more than one outlet to reduce width of the drain.
- c. The rectangular drains shown in Figure (d) may be difficult to construct because of the depth. A trapezoidal section could be used to a depth of 8 ft. with a narrow rectangular section to a depth of 16 ft., basing capacity of the system on the area of the trapezoid.

Example C-7: Foundation trench drain
with pipe.

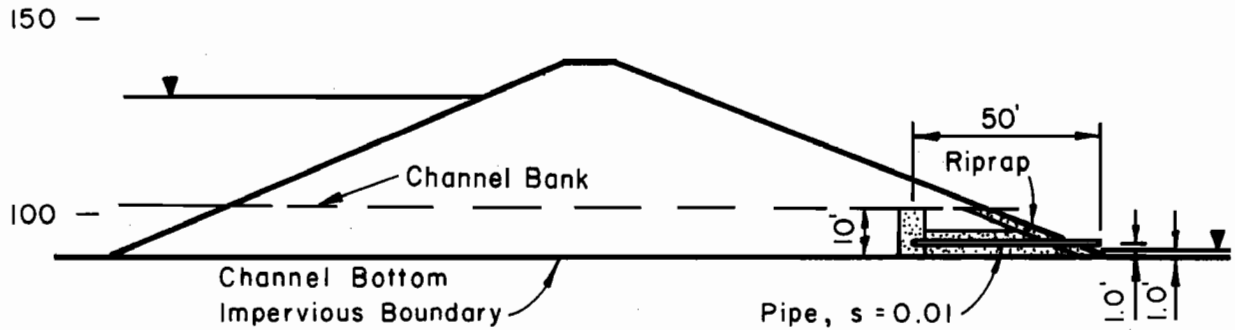

Figure (a). Section A-A.

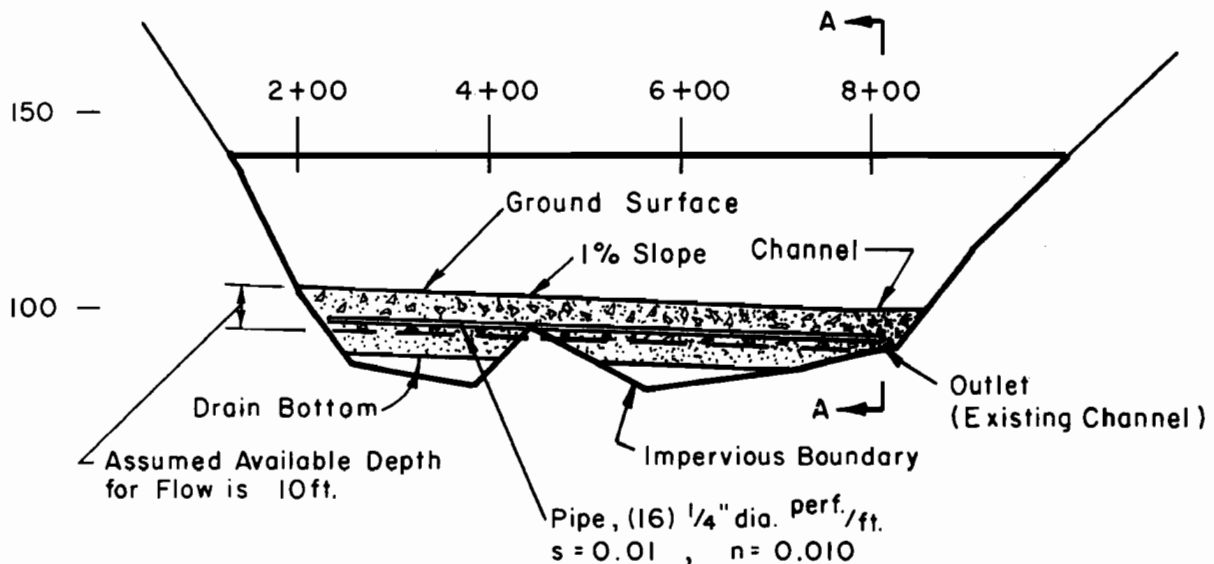

Figure (b). Drain profile.

Proportion the drain for this major structure so that the drain material carries 100% of the design discharge and the pipe carries 100% of the design discharge.

Design discharges are 1920 cfd. at Sta. 4 + 40 and 3360 cfd. at Sta. 8 + 00. Permeability, k , of the drain fill is 10,000 fpd.

Example C-7 (continued)

Determine dimensions of the drain material.

1. Sta. 4+40: $q_d = 1920$ cfd., $k_d = 10,000$ fpd., $i = 0.01$

$$A = \frac{q_d}{k_d i} = \frac{1920}{10,000 \times 0.01} = 19.2 \text{ sq. ft.}$$

$$\text{Since depth} = 10 \text{ ft.}, W = \frac{19.2}{10} = 1.92 \text{ ft. (use 2 ft.)}$$

2. Sta. 8+00: $q_d = 3360$ cfd., $k_d = 10,000$ fpd., $i = 0.01$

$$A = \frac{q_d}{k_d i} = \frac{3360}{10,000 \times 0.01} = 33.6 \text{ sq. ft.}$$

$$\text{Since depth} = 10 \text{ ft.}, W = \frac{33.6}{10} = 3.36 \text{ ft. (use 4 ft.)}$$

Note: The widths (W) in steps 1 and 2 apply to the drain materials only. If filter material is needed, trench widths must be increased. Depth of the drainage system should extend to the drain bottom shown in Figure (b).

3. Outlet. Capacity required is the same as for Sta. 8+00 of the trench drain. Use a section 8 ft. wide and 5 ft. deep which provides the required flow area and should be easy to construct in the old channel. This assumes that the old channel downstream will provide free drainage and not be blocked by subsequent backfilling.

Note: By Darcy's law, capacity of this outlet is adequate with tailwater 10 ft. above outlet channel flow line because slope is 0.01.

$$q = k_i A = 10,000 \times 0.01 \times 40 = 4000 \text{ cfd.} \\ \text{compared to inflow of } 3360 \text{ cfd.}$$

Determine pipe size.

1. Check capacity of perforations assuming that orifice head will not exceed 1.0 ft. Design discharge is 1920 cfd./240 ft. = 8 cfd./ft. (maximum inflow/ft. length of drain).

From Appendix A

Fig. A-3. $A = 0.8$ sq. in. per ft. with 16, 1/4 in. dia. circular perforations per ft.

Fig. A-4. $q = 0.0077$ cfs. per ft. = 665 cfd./ft. (> max. inflow) Therefore, specified perforations are adequate.

Example C-7 (continued)

2. Check pipe flow. Max. depth = $3/4$ pipe dia. Use ES-97, NEH Section 5.

Trench drain at Sta. 8+00 and outlet: $s = 0.01$, $s^{1/2} = 0.1$,
 $n = 0.010$, $q = 3360$ cfd. = 0.039 cfs.

From ES-97, sheet 3: $\frac{nq}{D^{8/3}s^{1/2}} = 0.422$ for $d/D = 0.75$

$$D^{8/3} = \frac{0.010 \times 0.039}{0.422 \times 0.1} = 0.00925$$

$$D = 0.00925^{3/8} = 0.173 \text{ ft. or } 2.08 \text{ in. (use 4 in. dia.)}$$

3. Check flow depth. $D = 4$ in. or 0.33 ft.

$$\frac{nq}{D^{8/3}s^{1/2}} = \frac{0.010 \times 0.039}{0.053 \times 0.1} = 0.0735$$

From ES-97, sheet 3: $d/D = 0.269$

$$d = 0.269 \times 0.33 = 0.089 \text{ ft. or } 1.07 \text{ in.}$$

< 3 in. OK

4. A 4-in. dia. pipe is satisfactory for the trench drain and the outlet.

Note: The design discharges used in these calculations are ten times the estimated seepage quantities (see Example C-6). With both the drain material and the pipe functioning as intended, the system is capable of handling twenty times the estimated seepage quantities. Because of this conservatism, the dimensions of the drain materials might be reduced to 2 ft. by 5 ft. (Sta. 2+00 to 4+40) and 4 ft. by 5 ft. (Sta. 4+40 to outlet). This reduction provides a factor of five for the drain materials and a factor in excess of ten for the pipe.

Example C-8 (continued)

Trial No. 1

$$1. L_1 = \left(\frac{k_F Z D}{k_b} \right)^{1/2} = \left(\frac{4 \times 20 \times 20}{0.01} \right)^{1/2} = 400 \text{ ft.}$$

$$L_e = L_1 + L_2 = 400 + 214 = 614 \text{ ft.}$$

$$2. Q_w = k_F \frac{H}{L_e} Da = 4.0 \frac{35}{614} 20a = 4.56a$$

$$3. L_w = h_d - \frac{2D}{3} = 36 - \frac{2(20)}{3} = 22.67 \text{ ft.}$$

$$4. H_w = \frac{Q_w L_w}{k_w A_w} = \frac{(4.56a)(22.67)}{(2500)(0.785)} = 0.0527a$$

5. Plot $h_d = 36 \text{ ft.}$ on Figure (b).

6. Plot $h_w = (h_d + H_w)$ vs. a on Figure (b).

a, ft.	H_w , ft.	$h_d + H_w$, ft.
0	0	36
38	2.0	38

7. Plot $h_m = 40 \text{ ft.}$ on Figure (b).

$$8. 2r_w = \frac{2r_h + 2r_c}{2} = \frac{24 + 12}{2} = 18 \text{ in. (use curve for 20 in.)}$$

9. From Figure B-3 (Appendix B), read H_m for various assumed a values with $H/L_e = 35/614 = 0.057$.

a, ft.	H_m , ft.	$h_m - H_m$, ft.
0	0	40
20	0.4	39.6
30	0.7	39.3
40	1.0	39.0
50	1.3	38.7

Plot $h_w = (h_m - H_m)$ vs. a on Figure (b).

10. The intersection of the two curves gives a well spacing, a , of 50 ft. and $H_w = 2.6 \text{ ft.}$

Example C-8 (continued)

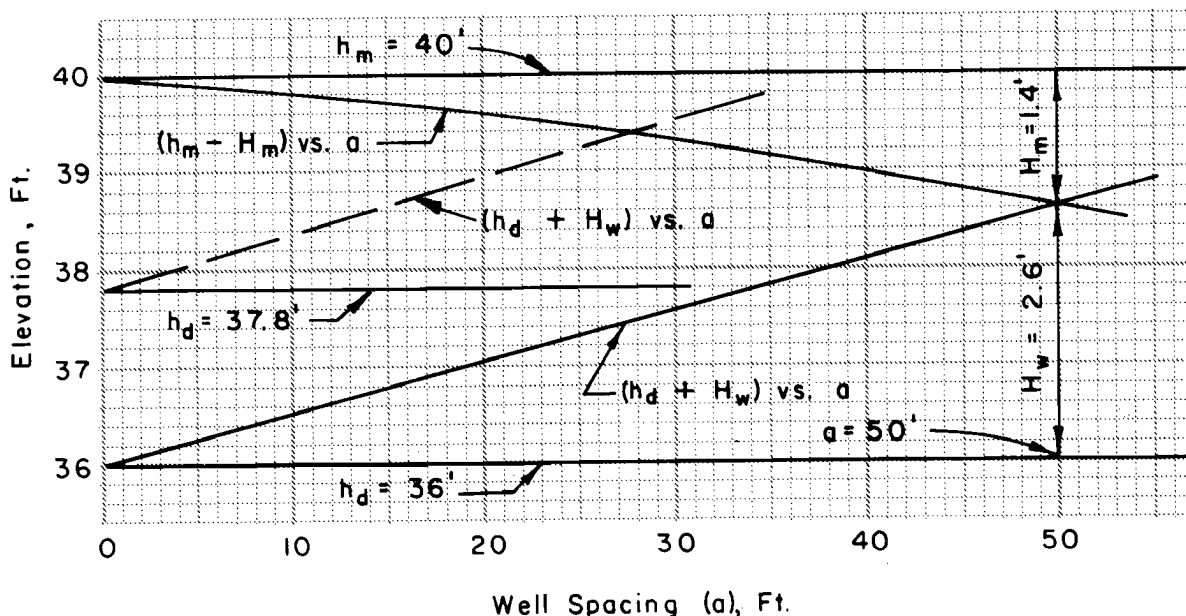

Figure (b). Head loss vs. well spacing

11. From Figure B-8 (Appendix B), the allowable gradient, i_w , is 0.067 for $k_w = 2500$ fpd and laminar flow. The allowable $H_w = i_w L_w = (0.067)(22.67) = 1.52$ ft. Since this is less than H_w for $a = 50$ ft., velocity $i_w k_w = Q_w/A_w$ must be reduced. Try increasing h_d which in turn will increase the length of the flow path in the well and decrease the spacing.

Trial No. 2

Approximate h_d by setting $H_w = 0.0527a = 1.52$ ft. (from steps 4 and 11). $a = 1.52/0.0527 = 29$ ft. and from Figure (b), $H_m = 0.7$ ft. Then $h_d = 40 - 0.7 - 1.5 = 37.8$ ft. and $L_w = 37.8 - 13.3 = 24.5$ ft. The allowable $H_w = (0.067)(24.5) = 1.64$ ft.

12. $L_e = 614$ ft. (as before)
13. $Q_w = 4.56a$ (as before)
14. $H_w = \frac{Q_w L_w}{k_w A_w} = \frac{(4.56a)(24.5)}{(2500)(0.785)} = 0.0569a$
15. Plot $h_d = 37.8$ ft. on Figure (b).

Example C-8 (continued)

16. Plot $h_w = (h_d + H_w)$ vs. a on Figure (b) - dashed line

a , ft.	H_w , ft.	$h_d + H_w$, ft.
0	0	37.8
35	2.0	39.8

17. $h_m = 40$ ft. (as before)
18. $h_m - H_m$ (as before)
19. The intersection of the two curves gives a well spacing of 28 ft. with $H_w = 1.6$ ft.
20. $H_w = 1.6$ ft. < allowable $H_w = 1.64$ ft. (OK)
Use 25 ft. well spacing with discharge at elev. 37.8 ft.

Part II

The required reduction in well velocity also can be achieved by holding the discharge at elevation 36.0 ft. and reducing the head at the toe below ground level by selection of appropriate well spacing.

Try $H = 36.9$ ft.; then $h_m = 38.1$ ft.
 $h_d = 36.0$ ft.

- $L_e = 614$ ft. (as before)
- $Q_w = k_f \frac{H}{L_e} Da = 4 \frac{36.9}{614} 20a = 4.80a$
- $L_w = h_d - \frac{2D}{3} = 36.0 - 13.33 = 22.67$ ft.
- $H_w = \frac{Q_w L_w}{k_w A_w} = \frac{(4.80a)(22.67)}{(2500)(0.785)} = 0.0554a$
- Plot $h_d = 36.0$ ft. on Figure (c).
- Plot $h_w = h_d + H_w$ vs. a on Figure (c).

a , ft.	H_w , ft.	$h_d + H_w$, ft.
0	0	36.0
36	2.0	38.0

7. Plot $h_m = 38.1$ ft. on Figure (c).

Example C-8 (continued)

8. From Figure B-3 (Appendix B), read H_m for various assumed a values with $H/L_e = 36.9/614 = 0.060$.

a, ft.	H_m , ft.	$h_m - H_m$, ft.
0	0	38.1
20	0.4	37.7
30	0.7	37.4
40	1.0	37.1
50	1.4	36.7

Plot $h_w = (h_m - H_m)$ vs. a on Figure (c).

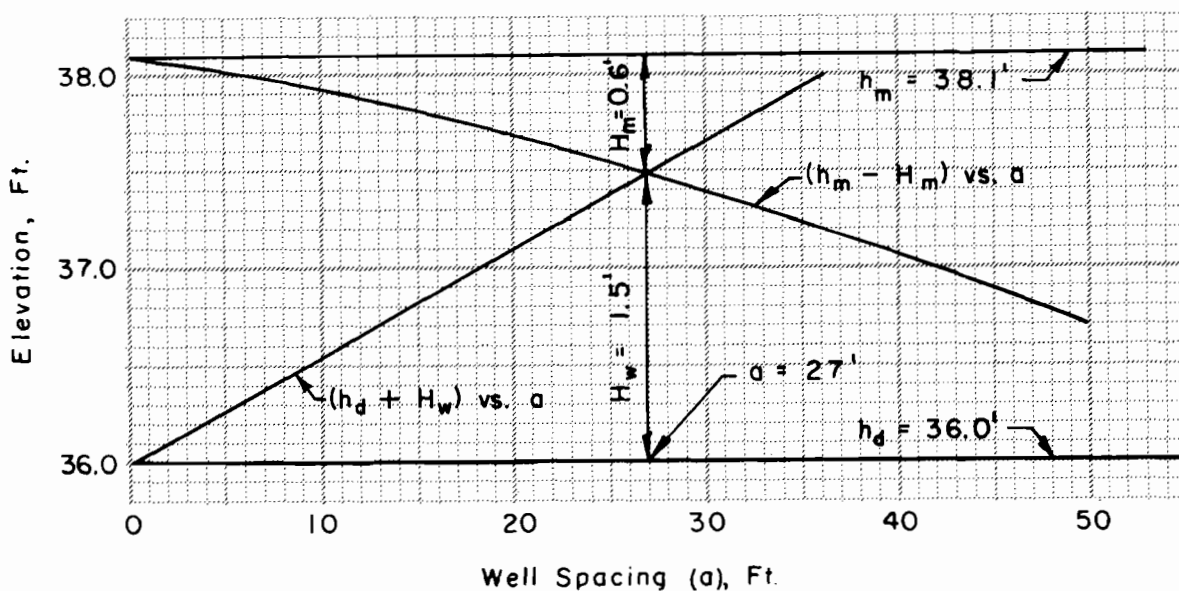

Figure (c). Head loss vs. well spacing

9. Intersection of curves gives a well spacing of 27 ft. and $H_w = 1.50$ ft.
10. $H_w = 1.5$ ft. < allowable $H_w = 1.52$ ft. (OK)
Use a well spacing of 25 ft. with discharge at elev. 36.0.

Part III

Another approach to reduce velocity in the well is to enlarge the drainage core. This should also increase the spacing.

Try 20" diameter core in 30" diameter hole with $h_d = 36.0$ ft., $h_m = 40.0$ ft. and $k_w = 2500$ fpd. $L_w = 22.67$ ft., $r_c = 0.83$ ft., $A_w = 2.182$ sq.ft.

Example C-8 (continued)

1. $L_e = 614$ ft., $H = 35$ ft.
2. $Q_w = 4.56a$ (from Part I)
3. $H_w = \frac{Q_w L_w}{k_w A_w} = \frac{(4.56a)(22.67)}{(2500)(2.182)} = 0.019a$
4. Plot $h_d = 36.0$ ft. on Figure (d).
5. Plot $h_w = (h_d + H_w)$ vs. a on Figure (d).

a, ft.	H_w , ft.	$h_d + H_w$, ft.
0	0	36
100	1.9	37.9

6. Plot $h_m = 40.0$ ft. on Figure (d).
7. $2r_w = \frac{2r_h + 2r_c}{2} = \frac{30 + 20}{2} = 25$ in. (use curves for 24 in.)
8. From Figure B-2 (Appendix B), read H_m for various assumed a values with $H/L_e = 35/614 = 0.057$.

a, ft.	H_m , ft.	$h_m - H_m$, ft.
0	0	40.0
20	0.4	39.6
40	1.0	39.0
60	1.7	38.3
80	2.4	37.6
100	3.2	36.8

Plot $h_w = (h_m - H_m)$ vs. a on Figure (d).

9. Intersection of the curves gives a well spacing of 82 ft. with $H_w = 1.55$ ft.
10. $H_w = 1.55$ ft. \approx allowable $H_w = 1.52$ ft. (OK)
Use well spacing of 80 ft. with discharge at elev. 36.0 ft.

Example C-8 (continued)

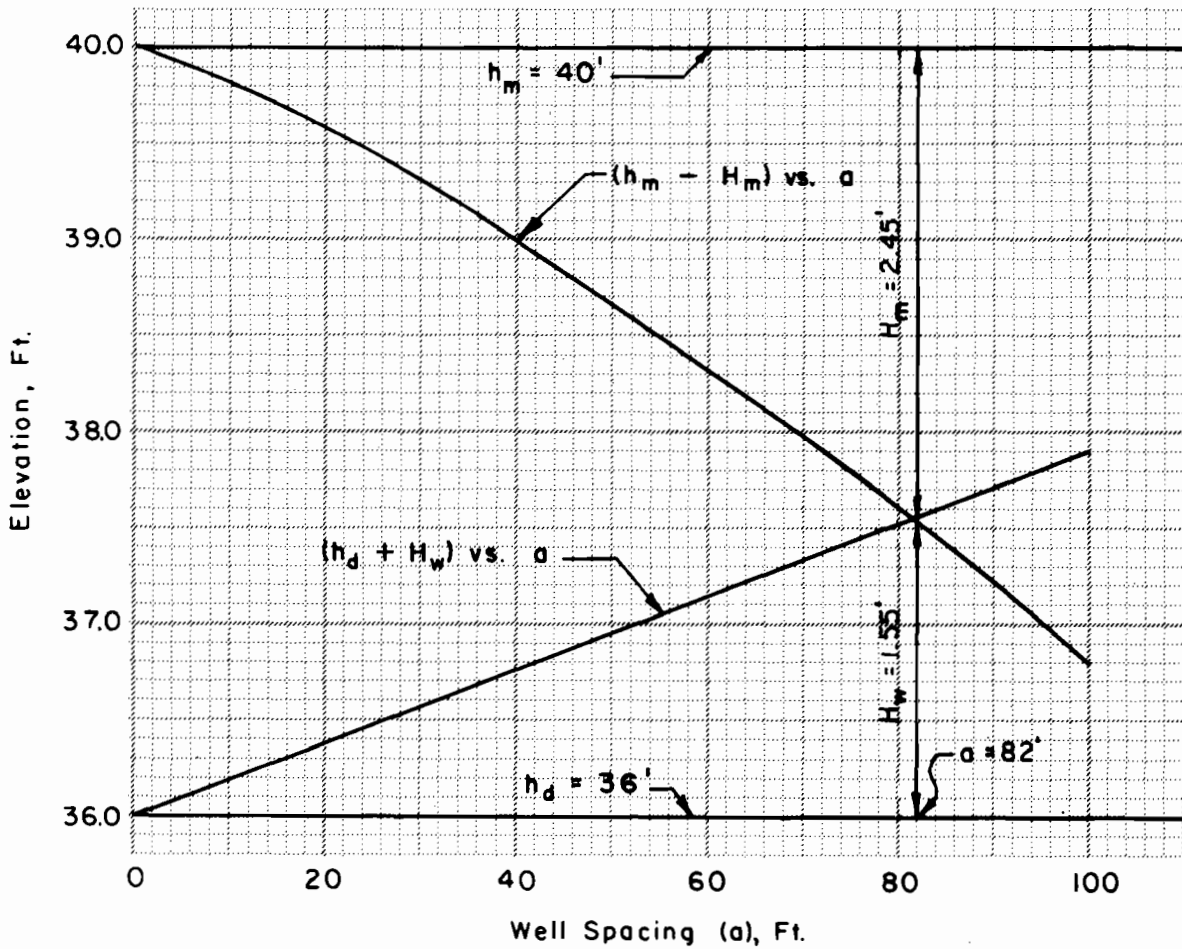

Figure (d). Head loss vs. well spacing

Example C-9. Partially penetrating blind wells

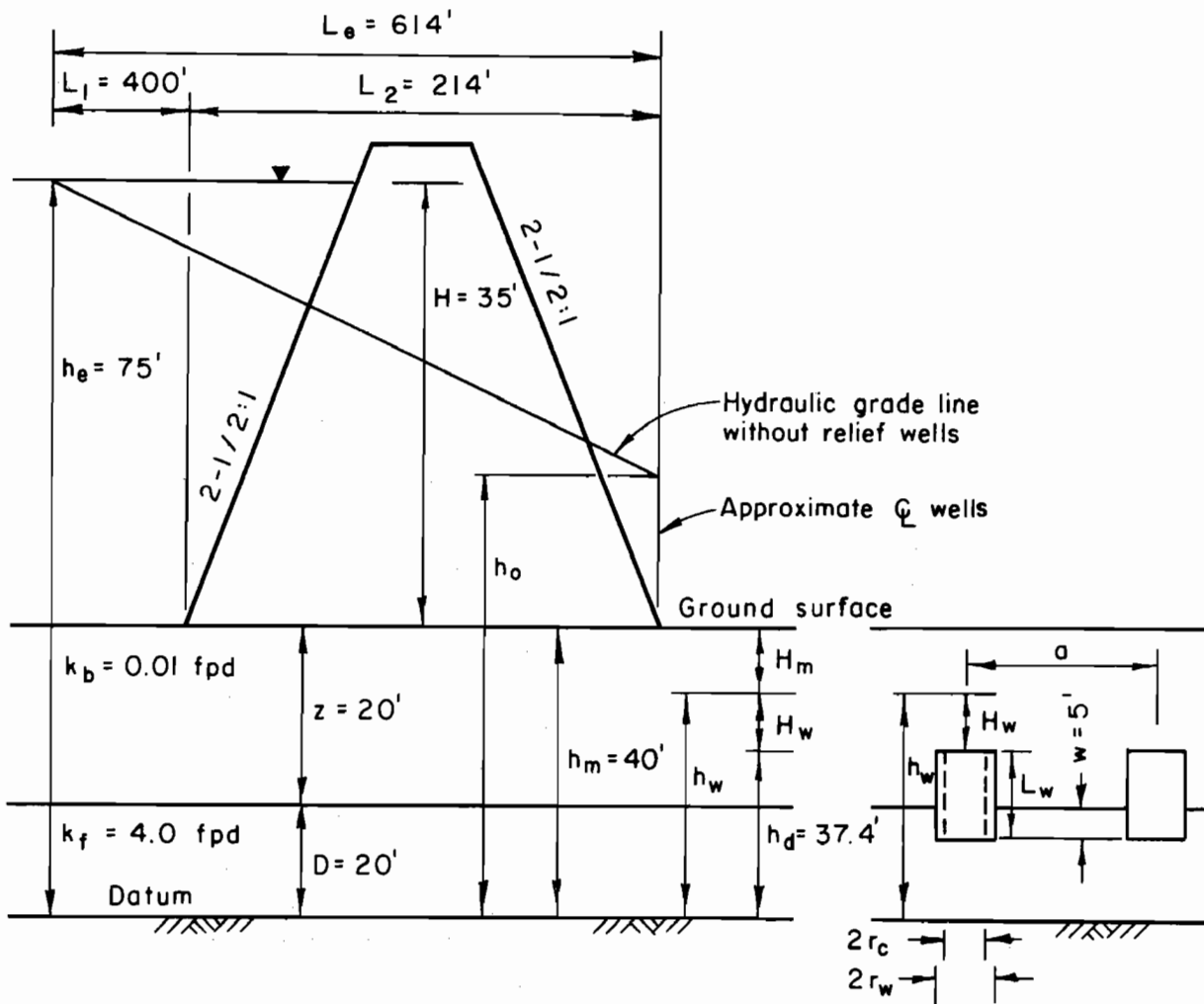

Figure (a). Sketch
(not to scale)

Site conditions are the same as used in Example C-8. Consider partially penetrating blind wells with the depth of penetration (w) = 5 ft. and a discharge elevation of 37.4 ft. The aquifer is essentially homogeneous and isotropic.

$$2r_h = 24", \quad 2r_c = 12", \quad k_w = 2500 \text{ fpd}, \quad A_w = 0.785 \text{ sq.ft.}$$

$$1. \quad H = 35 \text{ ft.}, \quad L_e = 614 \text{ ft.}$$

$$2. \quad Q_w = k_f \frac{H}{L_e} Da = 4 \frac{35}{614} 20a = 4.56a$$

$$3. \quad L_w = h_d - (D - w) = 37.4 - (20 - 5) = 22.4 \text{ ft.}$$

Example C-9 (continued)

$$4. H_w = \frac{Q_w L_w}{k_w A_w} = \frac{(4.56a)(22.4)}{(2500)(0.785)} = 0.0520a$$

5. Plot $h_d = 37.4$ ft. on Figure (b).

6. Plot $(h_d + H_w)$ vs. a on Figure (b).

a , ft.	H_w , ft.	$h_d + H_w$, ft.
0	0	37.4
50	2.6	40.0

7. Plot $h_m = 40.0$ ft. on Figure (b).

$$8. 2r_w = \frac{2r_h + 2r_c}{2} = \frac{24 + 12}{2} = 18 \text{ in. (use curve for 20 in.)}$$

9. Plot $(h_m - H_m)$ vs. a on Figure (b). (See Example C-8, Part I, step 7.)

10. From Figure B-9 (Appendix B) with $w = 5$ ft., $D = 20$ ft., $r_w = 0.833$ ft., $\frac{r_w}{w} = 0.167$, and $\frac{w}{D} = 0.25$, obtain $G = 0.717$.

11. Read H_m (full penetration) from Figure B-3 (Appendix B) for various a values with $H/L_e = 35/614 = 0.057$. Correct a to Ga .

a , ft.	H_m , ft.	$h_m - H_m$, ft.	Ga , ft.
0	0	40	0
20	0.4	39.6	14.3
30	0.7	39.3	21.5
40	1.0	39.0	28.7
50	1.3	38.7	35.9

Plot $h_m - H_m$ (full penetration) vs. Ga on Figure (b).

12. Intersection of the $(h_m - H_m)$ vs. Ga and $(h_d + H_w)$ vs. a curves gives a well spacing of 30 ft. $H_w = 1.55$ ft.

13. From Example C-8, Part I, allowable $H_w = 1.52$ ft. (close enough). Use a well spacing of 30 ft. with a discharge elevation of 37.4 ft.

Example C-9 (continued)

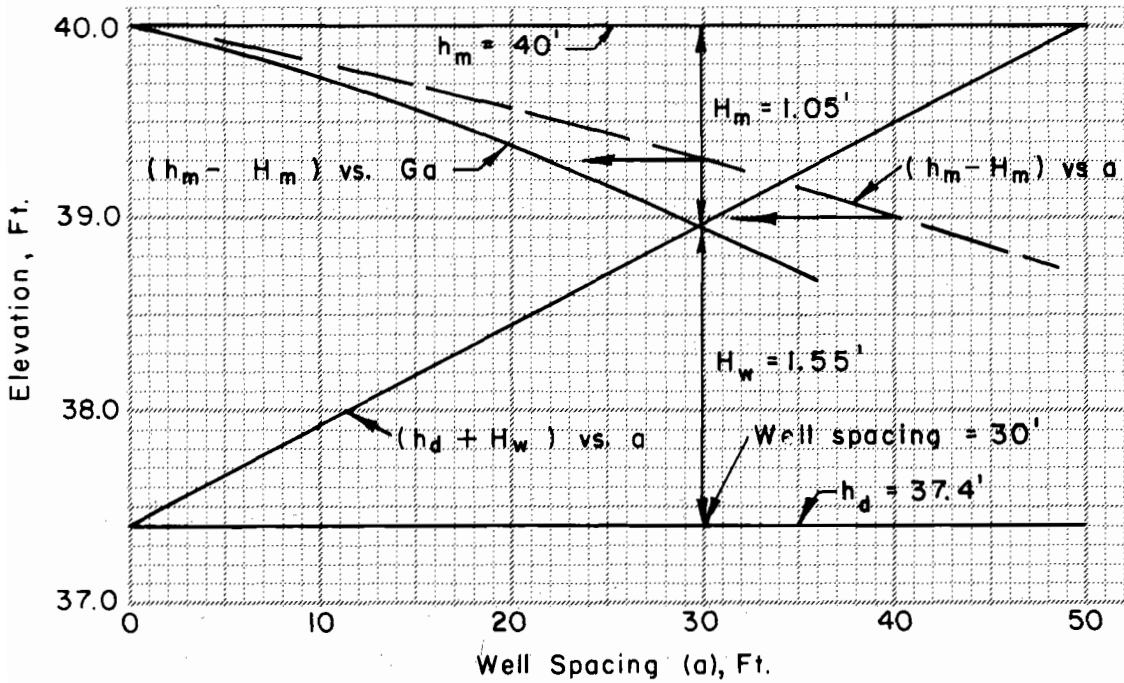

Figure (b). Head loss vs. well spacing

Example C-10. Fully penetrating relief well with screen

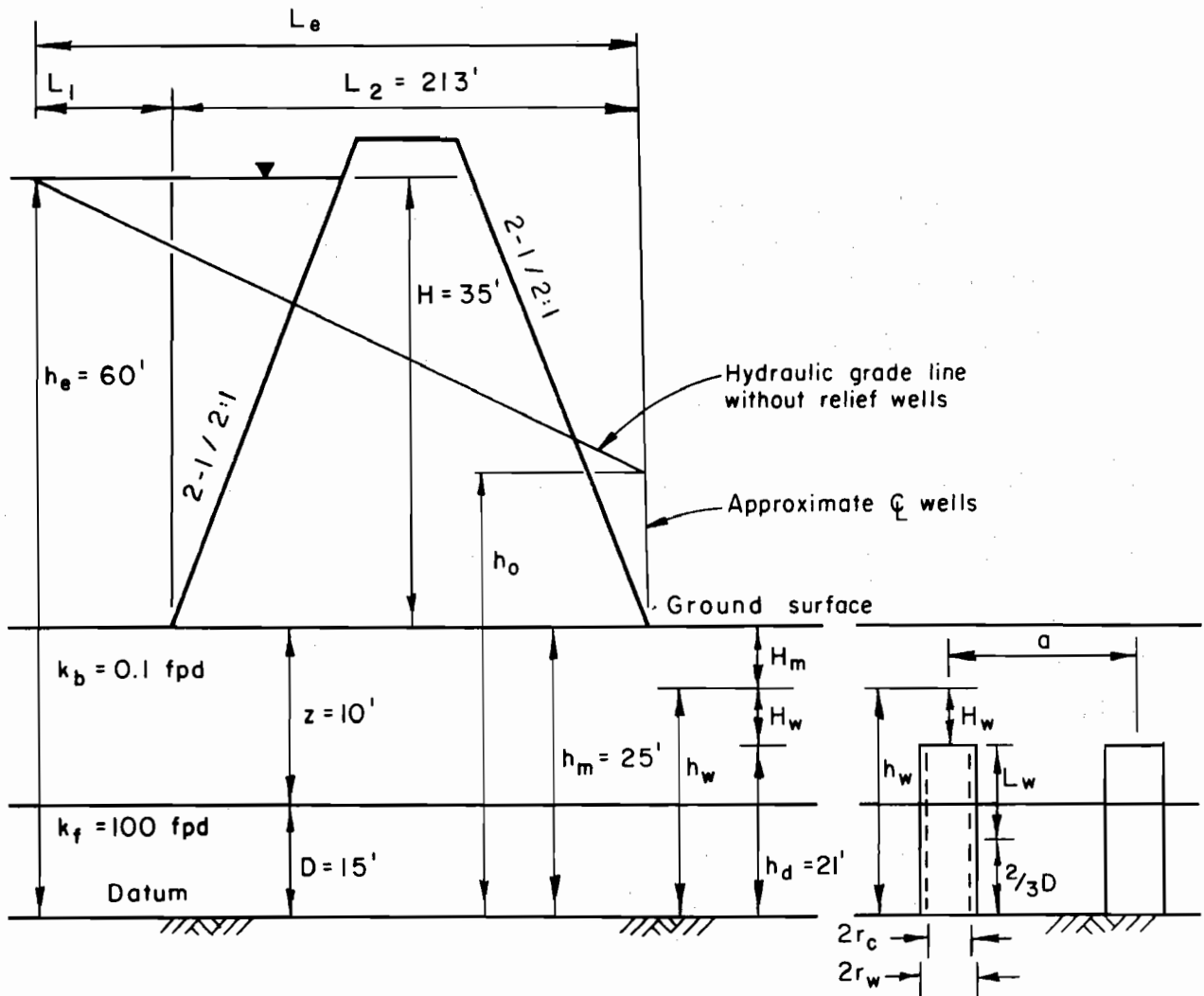

Figure (a). Sketch
(not to scale)

Determine well spacing if discharge is at height 21.0 ft. Reduce head at toe to ground level. Use fully penetrating wells with 4" diameter pipe and 6" filter pack.

$$2r_c = 4 \text{ in.}, 2r_h = 16 \text{ in.}, h_m = 25 \text{ ft.}, h_d = 21 \text{ ft.}$$

$$1. \quad L_1 = \left[\frac{k_f z D}{k_b} \right]^{1/2} = \left[\frac{(100)(10)(15)}{0.1} \right]^{1/2} = 387 \text{ ft.}$$

$$L_e = L_1 + L_2 = 387 + 213 = 600 \text{ ft.}$$

$$H = 35 \text{ ft.}$$

$$2. \quad Q_w = k_f \frac{H}{L_e} D a = 100 \frac{35}{600} 15 a = 87.5 a. \quad \text{Assume values of } a, \text{ compute } Q_w, \text{ and tabulate in table on next page.}$$

Example C-10 (continued)

3. $H_w = H_f + H_v + H_x$ (neglect screen loss by limiting v to 0.1 fps or less)

$$L_w = h_d - \frac{2D}{3} = 21 - 10 = 11 \text{ ft.}$$

$H_f = \frac{L_w}{100} (H_{f100}) = \left(\frac{11}{100}\right) (H_{f100}) = 0.11 H_{f100}$. With $C = 100$ obtain values of H_{f100} from Figure B-10 (Appendix B) and compute H_f .

Obtain H_v from Figure B-11 (Appendix B).

Considering 4 connections, $H_x = (4)(1.5)(H_v) = 6 H_v$.

a, ft.	Q_w , cfd	Q_w , gpm	H_{f100} , ft.	H_f , ft.	H_v , ft.	H_x , ft.	H_w	
20	1750	9.1	0.0145	0.0016	--	--	0.002	use
40	3500	18.2	0.051	0.0056	0.0034	0.0204	0.029	(0.03)
60	5250	27.3	0.110	0.012	0.0075	0.045	0.065	(0.07)
80	7000	36.4	0.185	0.020	0.014	0.084	0.118	(0.12)
100	8750	45.0	0.275	0.033	0.02	0.12	0.170	(0.17)

4. Plot $h_d = 21.0$ ft. on Figure (b).
 5. Plot $(h_d + H_w)$ vs. a on Figure (b).

a, ft.	$(h_d + H_w)$, ft.
40	21.03
60	21.07
80	21.12
100	21.17

6. Plot $h_m = 25$ ft. on Figure (b).

7. $2r_w = \frac{2r_h + 2r_c}{2} = \frac{16 + 4}{2} = 10$ in.

8. Read H_m from Figure B-6 (Appendix B) for various assumed a values with $H/L_e = 35/600 = 0.058$.

a, ft.	H_m , ft.	$(h_m - H_m)$, ft.
20	0.5	24.5
40	1.2	23.8
60	2.1	22.9
80	3.0	22.0
100	4.0	21.0

Plot $(h_m - H_m)$ vs. a on Figure (b).

Example C-10 (continued)

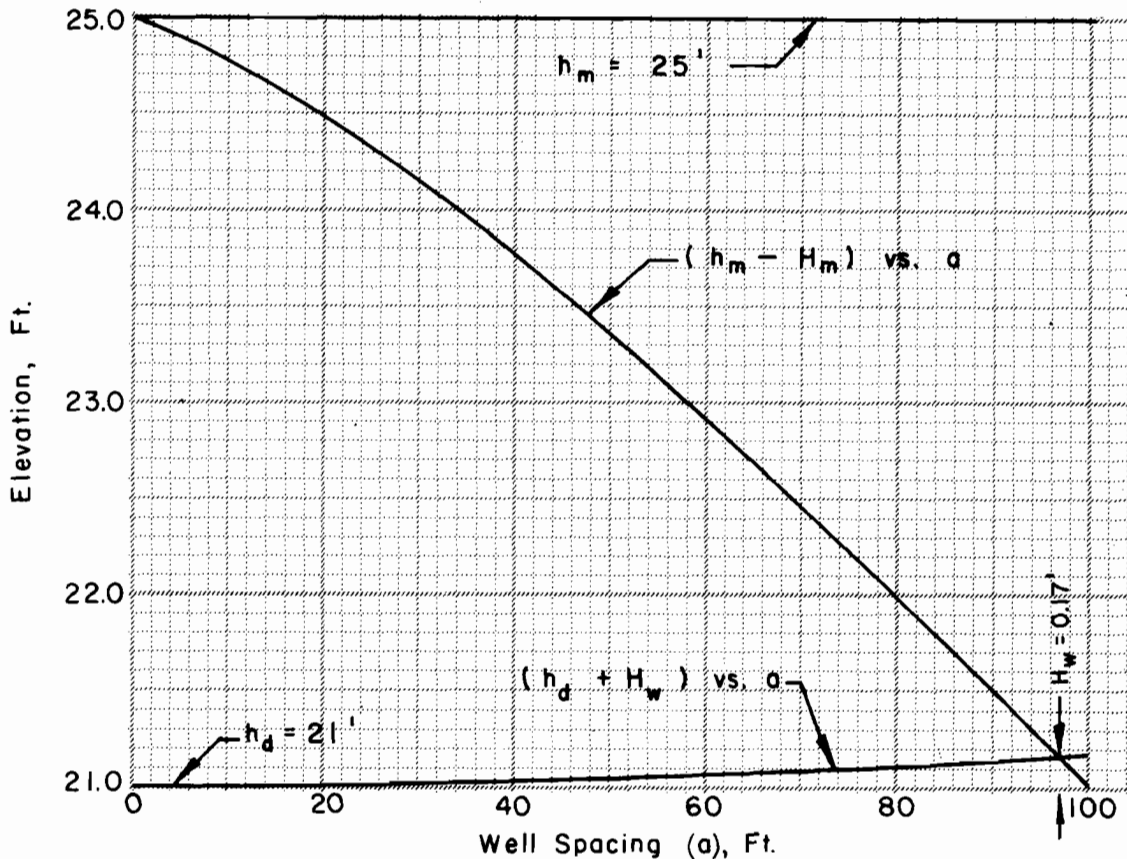

Figure (b). Head loss vs. well spacing

9. Intersection of the curves gives
 $a = 97$ ft. with $H_w = 0.17$ ft.
10. Use well spacing of 90 ft.

$$Q_w = 87.5 a = (87.5)(90) = 7880 \text{ cfd} = 0.09 \text{ cfs}$$

$$Q_w = (A)(v) \quad \text{Limit } v \text{ to } 0.1 \text{ fps (Appendix B)}$$

$$\text{Unclogged area of screen } (A) = \frac{0.09}{0.1} = 0.9 \text{ ft.}^2 = 130 \text{ in.}^2$$

$$\text{Total screen opening } (A_s) = \frac{A}{0.6} = \frac{130}{0.6} = 217 \text{ in.}^2$$

Well screen length is 14 ft. Select a screen that has at least $217/14 = 15.5 \text{ in.}^2$ opening per foot length and is compatible with gradation of filter material.



1
-
5





