

U.S. Department of Agriculture
Soil Conservation Service
Engineering Division

SOIL MECHANICS NOTE NO. 7
THE MECHANICS OF SEEPAGE ANALYSES

October 1979



Table of Contents

	<u>Page No.</u>
I. Purpose and Scope	1
II. Introduction	1
III. Required Site Information	1
IV. Considerations relating to seepage analyses	2
V. Methods of analysis	3
A. Flow nets	3
B. Special cases	5
1. Phreatic line for an embankment	6
2. Unconfined aquifer with vertical or steeply sloping inlet and outlet faces	6
3. Confined aquifer with finite length	13
4. Blanket-Aquifer Situations	13
Appendix A - Examples	



Soil Mechanics Note No. 7: The Mechanics of Seepage Analyses

I. Purpose and scope

Accepted methods for analysis of seepage and groundwater flow are presented herein. Most of these methods are generally applicable to a variety of structures and foundations. Analytical and graphical procedures are given with examples to demonstrate their use.

II. Introduction

The principles of water flow through soils are used to determine seepage quantities, pressures, and forces. There are approximate solutions for specific boundary conditions. These are generally limited to the solution of one value, usually seepage quantity. The process of determining boundary conditions, selecting permeability values, and making the analysis is a logical approach for evaluating structure and foundation performance and for selecting appropriate control measures. Refer to Soil Mechanics Note No. 6 for definitions.

III. Required site information

Site information specifically relating to permeability of materials and seepage flow must be collected for each site. This includes information for locating boundaries between materials of different permeability. Generally, the following items are required to evaluate site conditions for making seepage analysis:

- A. Topographic maps of the site area.
- B. Detailed geologic maps and sections of the site that contain correlation of all strata or zones between investigation points. Maps should include features such as reservoirs, channels, and other items that may affect downstream areas and adjacent valleys. Geologic information is to be interpreted to indicate uniformities, discontinuities, isotropy, anisotropy, porosity, intervoid permeability, mass permeability, etc.
- C. Detailed logs and descriptions of all materials in the embankment foundation and reservoir abutments. Items such as gradation, soil structure, stratification, continuity of strata, bedrock profiles, artesian pressure, and moisture content are important.

- D. Location, depth, gradient, and extent of water tables.
- E. Direction of ground water flow.
- F. Pressure gradients in and from confined layers. (Piezometric levels at various locations and depths.)
- G. Permeability of all materials in the condition under which they will exist after the structure has been constructed.
- H. Geometry of the structure and the related upstream and downstream water levels during the planned operation.

IV. Considerations relating to seepage analysis

- A. Prepare cross sections to scale showing the boundaries of the structure, entrance and discharge faces, and boundaries of seepage parallel to the direction of flow. The various zones of material in the foundation and the structure must be delineated in relation to permeability and shown on the cross sections. Each cross section should represent a definite reach or area of the structure having similar head relationships and soil conditions. Sand gravel layers, natural blanket materials, broken or tight bedrock formations, and upstream and downstream water levels are of prime importance and should be included.
- B. In checking water budgets for storage reservoirs, computed losses may be based on heads commensurate with the permanent storage level. For slope stability analysis and checking piping potential, seepage pressures and gradients should be determined with the reservoir filled at least to the emergency spillway crest.
- C. Cross sections should be transformed when previous materials are stratified and/or anisotropic. Methods for making transformations are given in Soil Mechanics Note No. 5. Transformed sections can be used with either analytical or graphical methods.
- D. Analysis can be limited to the embankment core and foundation cutoff when the embankment shells and foundation soils have relatively high permeability in comparison to the permeability of the core and cutoff (100 to 1,000 times or greater). Where permeable strata extend through or under a relatively impervious structure, the seepage analysis is made only on the permeable strata.

- E. It is essential to recognize the limitations of data used. If a high degree of accuracy is needed, effort should first be spent in refining and collecting data before a refined analysis is made. The location of boundaries of seepage flow has a marked effect on the results of the analysis. These boundaries are often the most difficult item to define.

V. Methods of analysis

The methods used most frequently in SCS work are explained in this section. Other methods can be found in the listed references.

Some methods apply only to specific boundary conditions. All methods can be used to obtain seepage quantities but may not give seepage gradients, pressures, or forces.

The following table is provided as a guide to the information that can be obtained from each procedure:

Method	Gradients	Pressures	Seepage Quantity
Flow Net	X	X	X
Embankment Phreatic Line	X		X
Unconfined Aquifer (Dupuit's assumption)			X
Confined Aquifer of finite length and uniform thickness			X
Blanket-Aquifer, Continuous and Discontinuous)		X	X

A. Flow nets

A detailed explanation of flow nets including the construction and use in seepage analysis is given in Soil Mechanics Note No. 5. All the information including seepage quantities, pressures, gradients, forces, and velocities can be evaluated. In addition, flow nets can be constructed for any configuration of inlet, outlet, and flow boundaries.

Figure 1 contains the nomenclature, properties, and equations for making calculations and determinations from flow nets. Seepage gradients can be determined at any point in the flow net. This is done by dividing the drop in head between equipotential lines (Δh) by the distance between these lines (Δx) measured along the flow path. The seepage gradient changes throughout the flow net. The largest gradient occurs along the shortest flow path.

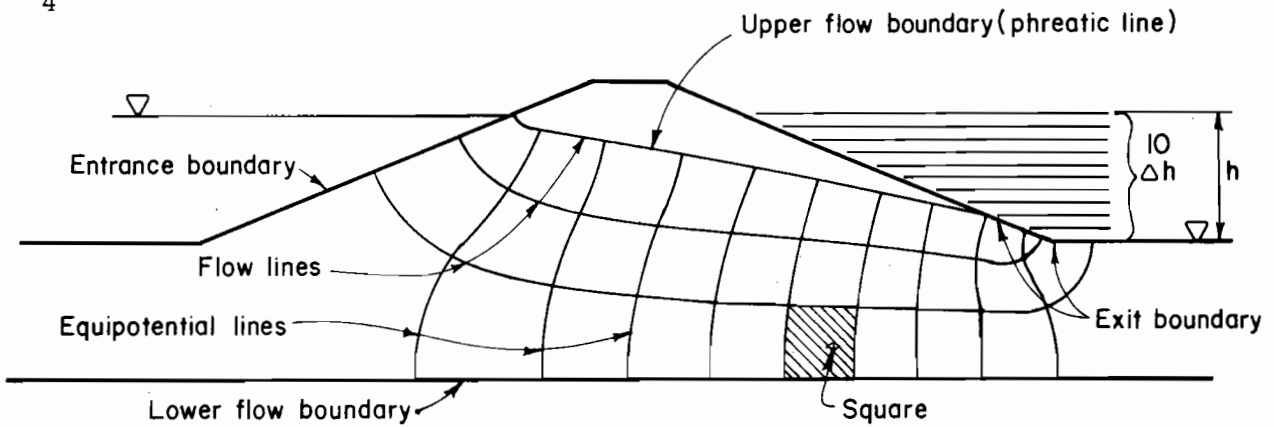

Flow net when k of embankment = k of foundation

Symbols :

h = head of water (upstream water surface minus downstream water surface)

Δh = head increment between equipotential lines = h/N_d

k = permeability coefficient

N_d = number of equipotential lines (drops) in flow net

N_f = number of flow channels in flow net

$\$$ = shape factor = N_f/N_d

L = total structure length normal to the section represented by the flow net cross section

$\Delta \ell$ = flow path length across square at discharge face (see sketch)

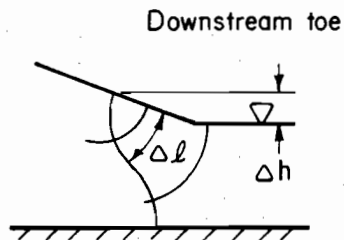

Equations :

Rate of discharge $q = kh\$$

Discharge gradient $i_d = \Delta h / \Delta \ell$

Seepage pressure $p_s = \gamma_w i_d$

Total seepage quantity $Q = qL$

Figure 1. Flow net properties and equations

The potential for piping can be evaluated for piping-prone soils with free discharge at a horizontal face (flow upward). The largest discharge gradient is compared to the critical (allowable) gradient for that material. The critical gradient for piping-prone soils is determined by calculating the gradient that will produce a seepage force equal to the buoyant weight of the soil.

Critical gradients for low plasticity soils can be calculated by dividing the buoyant unit weight of the soil by the unit weight of water. Normally, natural piping-prone soils will have critical gradients between approximately 0.8 and 1.0. Evidence of piping (sand boils) has occurred when measured gradients are below the calculated critical gradient. Tests during high water along the levees in the lower Mississippi Valley in 1950^{1/} indicated active sand boils were evident where gradients were measured at values between 0.5 and 0.8. This indicates a factor of safety of at least two may be needed when evaluating discharge gradients on the basis of calculated critical gradients.

Methods for evaluating critical piping conditions have not been developed using the flow net for seepage discharge on natural or embankment slopes. Controlled drainage is generally used to prevent discharge onto slopes consisting of piping-prone materials. Materials most likely to experience piping include silts or sandy silts of low or no plasticity (ML), silty fine sands (SM), silty clays of low plasticity (CL) ($PI < 15$), and most poorly graded fine sands (SP).

Seepage pressures may be determined at any point by deducting the head loss accrued to that point from the net head across the structure. Uniform distribution of pressure is assumed between equipotential lines. Average seepage velocities can be determined by dividing the seepage discharge within a flow channel by the area of the flow channel (distance between flow lines times a unit length of structure). The total seepage is equally divided between all flow channels.

B. Special cases

Methods have been developed for special boundary conditions whereby the seepage rate (q) or quantity (Q) can be determined. Estimates of pressures and gradients can also be made in some cases.

^{1/} ASCE Journal of the Soil Mechanics and Foundations Division.
Vol. 85, No. SM4, August 1959. W. J. Turnbull and C. I. Mansur

1. Phreatic line for an embankment

This method was developed by Casagrande² for embankments located on relatively impervious foundations ($k_e \geq 100k_f$). The procedure involves locating the line of saturation (phreatic line) through an embankment when full seepage equilibrium has developed. Seepage rate (q) can be calculated from certain points on the phreatic line. This method can be applied to embankments with various zoning patterns and drainage conditions as depicted in Figures 2, 3, 4, and 5. It can also be applied to transformed sections as depicted in Figure 6. Definitions of terms, assumptions, and methods of solution are indicated in the figures.

Seepage through the embankment above the base can be determined by this method. To be applicable, the slope angles (α) of the embankment and zones should be within the limits indicated in the figures. The method can be used on core sections of zoned earth fills and on transformed sections provided the ratio of d/h is greater than unity.

This method is used mainly for calculating the seepage discharge within a given reach of an embankment. It is also used to determine the line of saturation for stability calculations and may be used as a starting point for constructing a flow net. The construction of transformed sections is also covered in Soil Mechanics Note 5. It should be noted that whenever the seepage discharge is calculated for a transformed section, the coefficient of permeability to be used is

$$k' = \sqrt{(k_{\max})(k_{\min})}.$$

2. Unconfined aquifer with vertical or steeply sloping inlet and outlet faces

This method is based on Dupuit's^{3/} assumption. It is an exact solution for determining the discharge for the case shown in Figure 7 where the inlet and outlet faces are vertical and the base is impermeable. Few field situations fit the inlet and outlet configuration for an exact solution.

2/ "Seepage through Dams" by Arthur Casagrande, Contributions to Soil Mechanics. Boston Society of Civil Engineers, 1925-1940, pp 295-336

3/ Groundwater and Seepage by M. E. Harr, McGraw Hill, pp. 40

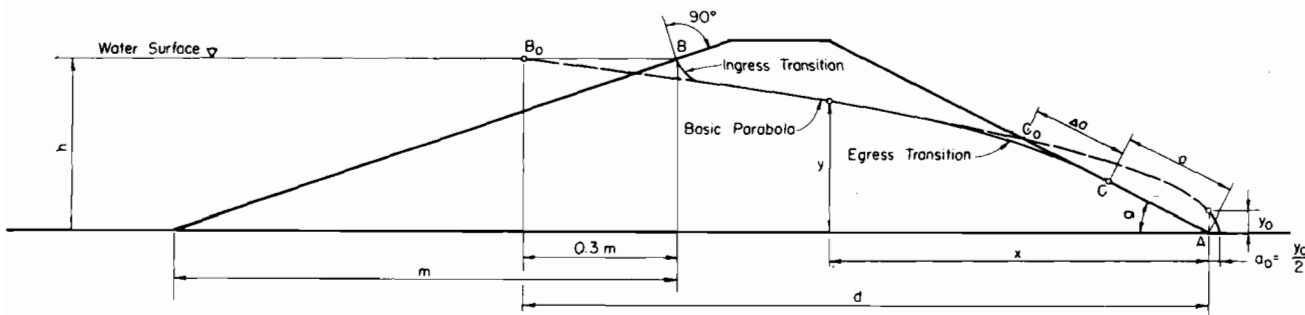

CROSS-SECTION OF DAM

ASSUMPTIONS

1. Homogeneous, isotropic cross-section.
2. Relatively impervious base.
3. $q = ky \frac{dy}{dx}$
4. No special toe drainage.

METHOD OF CONSTRUCTION

DEFINITION OF TERMS

- B_0 - Pt. of intersection of basic parabola and water surface.
- a - Slope distance from toe of dam to point of discharge.
- α - Angle of discharge face (from horizontal.)
- x, y - Coordinates of any point on the basic parabola, measured from toe of dam.
- a_0 - Distance along base line between toe of dam and vertex of basic parabola.
- y_0 - Ordinate of basic parabola at toe of dam.
- k - Coefficient of permeability of soil.
- q - Seepage discharge through dam per foot length
- C - Point at which phreatic line intersects discharge slope.
- C_0 - Point at which basic parabola intersects discharge slope.
- Δa - Distance between C and C_0 .

GRAPHICAL SOLUTION OF $a = \sqrt{h^2 + d^2} - \sqrt{d^2 - h^2 \cot^2 \alpha}$

1. Pass arc through B_0 with center at A to intersect the discharge face (extended) at point (1).
2. Pass a semi-circle through points (1) and (A) with center on discharge face.
3. Extend horizontal line through point B_0 to intersect the discharge face at point (2).
4. Project distance 2-A onto semi-circle (point 3).
5. Project distance 1-3 onto discharge face (point C).
6. $a = \overline{AC}$.

GRAPHICAL SOLUTION OF $y_0 = \sqrt{h^2 + d^2} - d$

1. Pass arc through B_0 with center at A to intersect the horizontal base.
2. $y_0 = R - d$.

ANALYTICAL SOLUTION ($0 < \alpha < 60^\circ$)

EQUATIONS:

1. $y_0 = \sqrt{h^2 + d^2} - d$
2. $a = \sqrt{h^2 + d^2} - \sqrt{d^2 - h^2 \cot^2 \alpha}$
3. $x = \frac{y^2 - y_0^2}{2y_0}$; $y = \sqrt{2y_0x + y_0^2}$
4. $q = ka \sin^2 \alpha$

PROCEDURE:

1. Draw cross-section of dam to scale.
2. Locate B_0 as shown.
3. Calculate values of (y_0) and (a).
4. Calculate values of (y) corresponding to various values of (x).
5. Plot basic parabola.
6. Sketch ingress transition.
7. Sketch egress transition (between parabola and point C).
8. Calculate (q).

From: "Seepage Through Dams" by A. Casagrande, Contributions to Soil Mechanics, Boston Society of Civil Engineers, 1925-1940, p. 275-336.

Figure 2. Phreatic Line Case I - Plain Cross Section

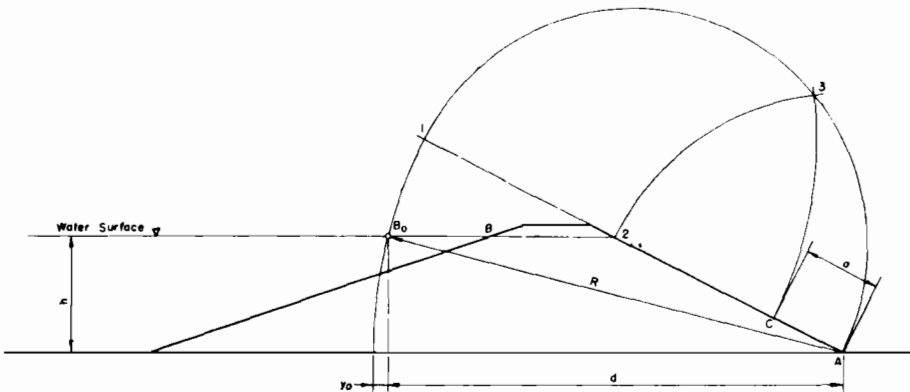

GRAPHICAL DETERMINATION OF (a) AND (y_0). FOR $0 < \alpha < 30^\circ$

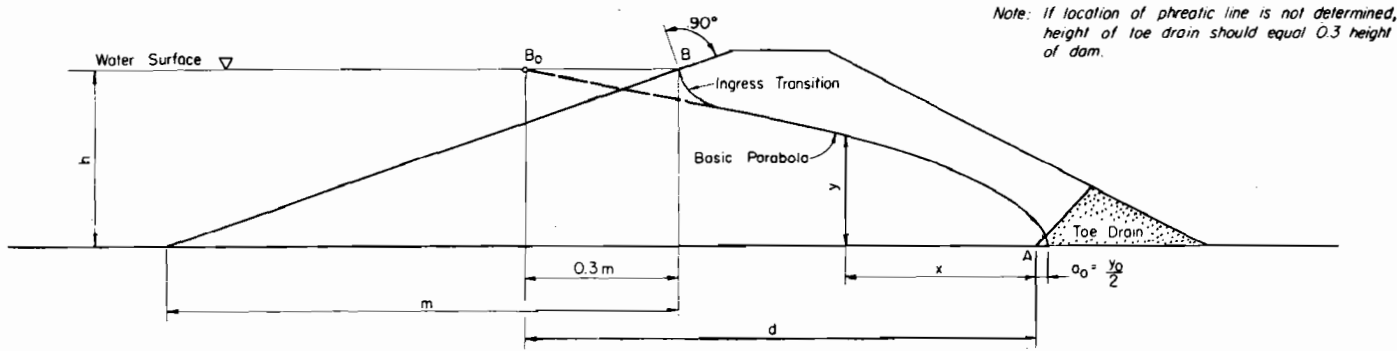

Note: If location of phreatic line is not determined, height of toe drain should equal 0.3 height of dam.

(a) CROSS-SECTION OF DAM

METHOD OF CONSTRUCTION

PROCEDURE:

1. Draw cross-section of dam to scale.
2. Determine location of B_0 as shown.
3. Calculate value of (y_0) .
4. Calculate values of (y) corresponding to various values of (x) .
5. Plot basic parabola and locate point C_0 .
6. Determine distance $\Delta C_0 = a + \Delta a$.
7. Determine value of (c) from -Figure (c) Below
8. Calculate value of $\Delta a = c(a + \Delta a)$.
9. Plot point (C).
10. Draw ingress and egress transitions.
11. Calculate (q) .

EQUATIONS:

1. $y_0 = \sqrt{h^2 + d^2} - d$
2. $y = \sqrt{2y_0x + y_0^2}$; $x = \frac{y^2 - y_0^2}{2y_0}$
3. $q = ky_0$ (approx.)

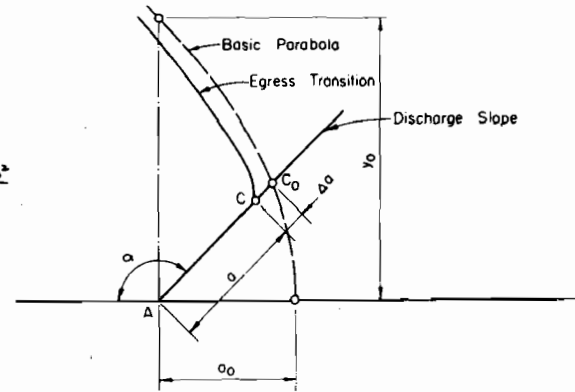

(b) DISCHARGE FACE ENLARGED FOR $90^\circ < \alpha < 180^\circ$

ASSUMPTIONS:

1. Homogeneous isotropic cross-section.
2. Relatively impervious base.
3. $60^\circ < \alpha < 180^\circ$

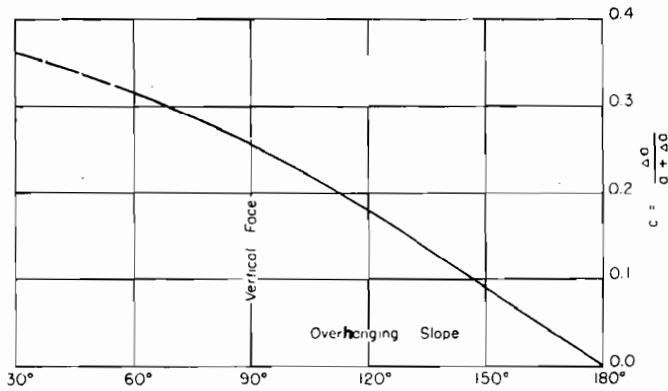

(c) RATIO OF (Δa) TO $(a + \Delta a)$

From: "Seepage Through Dams," by A. Casagrande, Contributions to Soil Mechanics, Boston Society of Civil Engineers, 1925-1940, p 275-336.

Figure 3. Phreatic Line Case II - Effect of Toe Drain

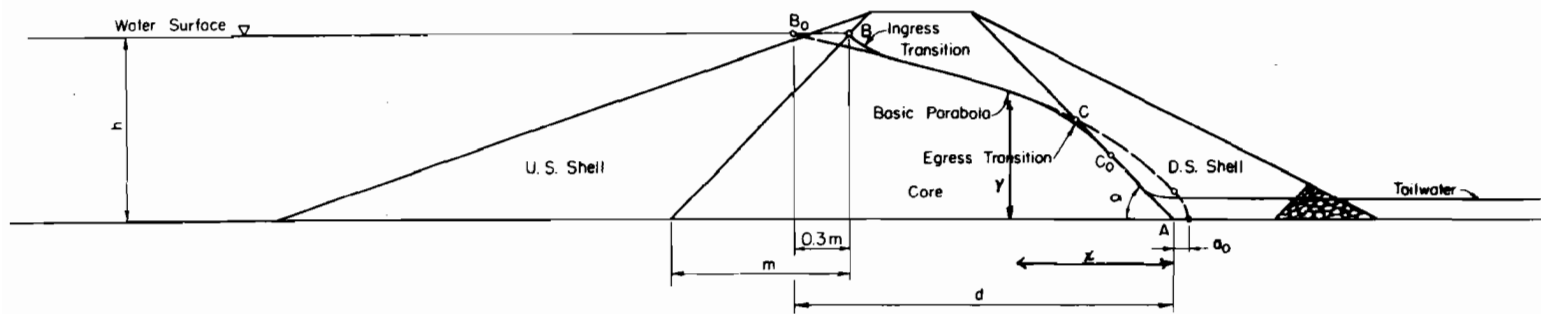

(a) CROSS-SECTION OF DAM

METHOD OF CONSTRUCTION

EQUATIONS:

1. $y_0 = \sqrt{h^2 + d^2} - d$
2. $a = \sqrt{h^2 + d^2} - \sqrt{d^2 - h^2 \cot^2 \alpha}$ (for $\alpha < 60^\circ$)
 Note: Where $\alpha > 60^\circ$, use Fig.(c) Case II.
3. $y = \sqrt{2y_0x + y_0^2}$; $x = \frac{y^2 - y_0^2}{2y_0}$
4. $q(\text{core}) = k \sin^2 \alpha$ (for $\alpha < 60^\circ$)
5. $q(\text{core}) = ky_0$ (for $\alpha > 60^\circ$)
6. $q(\text{d.s. shell}) = kiA = \frac{ky_0^3 A}{L}$

Where,

- k = coefficient of permeability of core.
- k_s = coefficient of permeability of shell.
- i = hydraulic gradient of flow through shell.
- h' = difference in elevation of seepage line through d.s. shell.
- L = length of path of flow through d.s. shell.
- A = average area under seepage line through d.s. shell.

PROCEDURE:

1. Draw cross-section of dam to scale.
2. Locate B_0 ; calculate y_0 and a .
3. Plot basic parabola.
 Note: Upstream shell is considered so pervious as to cause no effect on phreatic line through core.
4. Sketch ingress and egress transitions through core.
5. Calculate q through core.
6. Knowing q , (k_s) , and (L) , calculate (h') .
7. Sketch shell transition and seepage line.

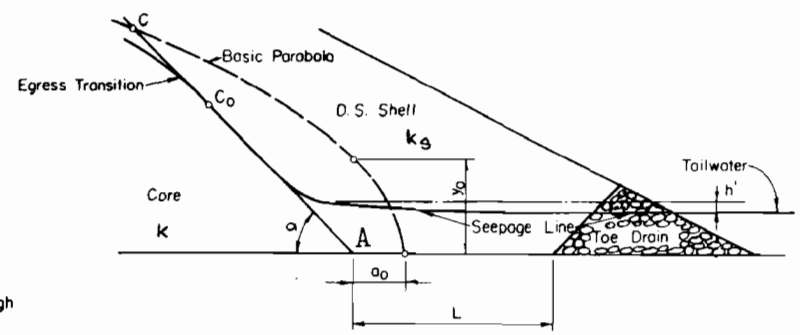

(b) DOWNSTREAM SHELL

Note: This method produces satisfactory results only when k_s is several hundred times as large as k . Example: Clay or silt core with sand and gravel shell.

From: "Seepage Through Dams," by A. Casagrande, Contributions to Soil Mechanics, Boston Society of Civil Engineers, 1925-1940, p 275-336.

ASSUMPTIONS:

1. Homogeneous core section.
2. Relatively impervious base.

Figure 5. Phreatic Line Case IV - Composite Section

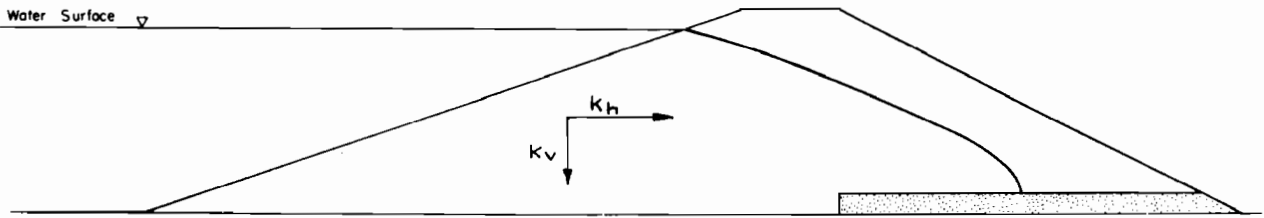

TRUE SECTION

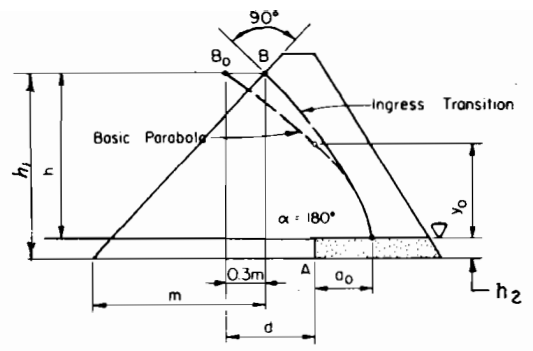

TRANSFORMED SECTION

METHOD OF CONSTRUCTION

To construct the phreatic line through a dam section composed of an anisotropic soil, the method of the transformed section is used.

Designating the maximum and minimum coefficients of permeability of the soil as k_{max} and k_{min} , the entire cross-section is transformed in such a manner that all dimensions in the direction of k_{max} are reduced by the factor:

$$\sqrt{\frac{k_{min}}{k_{max}}}$$

or that all dimensions in the direction of k_{min} are increased by the factor:

$$\sqrt{\frac{k_{max}}{k_{min}}}$$

The methods for constructing the phreatic line, shown in cases I-IV, are applicable to the transformed section. Case III is illustrated in this example ($k_h = 10k_v$).

Procedure: (Where $k_h > k_v$)

1. Draw the true cross-section of dam to scale.
2. Draw the transformed section of dam to scale.
 - a. Vertical dimensions remain the same as for true section
 - b. Horizontal dimensions are reduced by the factor: $\sqrt{\frac{k_v}{k_h}}$
3. Construct phreatic line through transformed section by methods shown in cases I-IV
4. Project phreatic line back to true section
 - a. Vertical dimensions remain the same.
 - b. Horizontal dimensions are increased by the factor: $\sqrt{\frac{k_h}{k_v}}$

5. Calculate discharge (q).

a. $q = k' y_0$ where $d > h$ and $\alpha > 60^\circ$
 b. $q = k' \frac{h_1^2 - h_2^2}{2d}$ where $d < h$

Note:- For computing discharge through the dam, the coefficient of permeability equals:

$$k' = \sqrt{k_v k_h}$$

Assumptions: for the transformed section

1. Homogeneous cross-section
2. Relatively impervious base.

From: "Seepage Through Dams," by A. Casagrande, Contributions to Soil Mechanics, Boston Society of Civil Engineers, 1925-1940, p 275-336.

Figure 6. Phreatic Line Case V - Anisotropic Soil

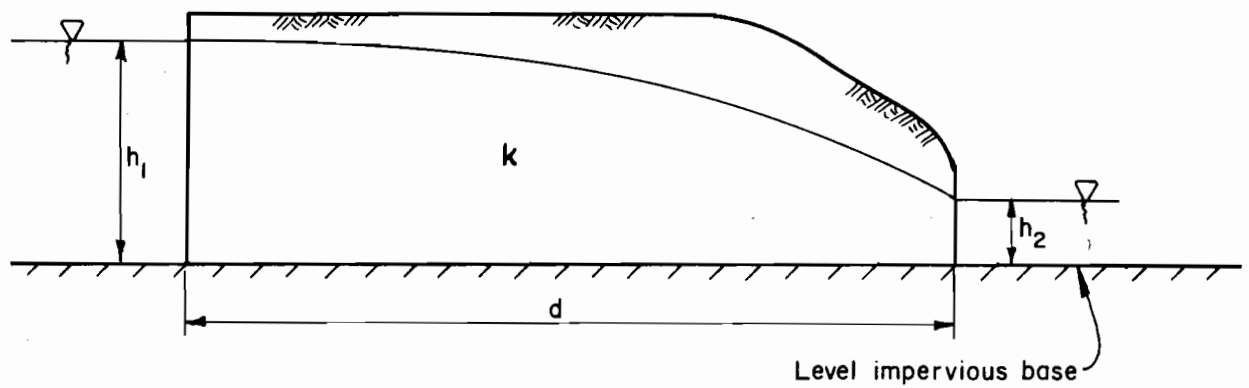

Flow from one body of water to another through an unconfined aquifer with vertical inlet and outlet faces :

$$q = k \frac{h_1^2 - h_2^2}{2d}$$

Figure 7. Unconfined aquifer with vertical inlet and outlet faces

It is reasonable to use this method on thin core sections in earth dams where the slopes of the core are relatively steep. Transformed sections where d/h is less than one, as shown on Figure 8, also fit in this category.

The seepage quantity through an abutment can be estimated by constructing a flow net in a typical horizontal plane for either confined or unconfined flow conditions. Dupuit's assumption has been applied to each flow line and equations written for calculating discharge through the abutment. This solution is considered theoretically correct for vertical abutments and relatively accurate for sloping abutments. Figure 9 shows an example of a horizontal flow net and indicates the applicable equations for calculating abutment seepage for both vertical and steeply sloping abutments.

3. Confined aquifer of finite length and uniform thickness

This method applies to a layer of permeable material that is bounded by a relatively impermeable layer on the bottom and by an impermeable structure or layer of given dimension (d) on the top (see Figure 10). Darcy's law can be applied directly when the downstream water level is above the top of the permeable layer. The solution is limited to the rate of discharge for this case.

The discharge rate can also be calculated when the tail-water level is below the top of the permeable layer. This is done by applying Darcy's law and Dupuit's assumption as indicated in Figure 11.

This method applies to a dam, dike, or diversion structure that has no cutoff trench and is constructed over a permeable layer. It can be used for any permeable layer with a uniform thickness that has a direct inlet in the reservoir and a direct outlet downstream from the structure. The permeable layers are often located through abutments or through the foundation beneath the dam.

4. Blanket-aquifer situations

This method has been developed from Bennett's^{4/} procedures for calculating seepage relationships with natural or constructed blankets of relatively low permeable material over pervious foundations. This method is used to (1) estimate seepage quantities through an aquifer under an earth dam that is overlain by a blanket, (2) estimate the factor of safety against uplift of the blanket at the downstream toe, and (3) determine the effects of discontinuous blankets or constructed upstream blankets.

^{4/} "The Effect of Blankets on Seepage through Pervious Foundations" by P. T. Bennett, ASCE Transactions, Vol. III, 1946, pp. 215-252.

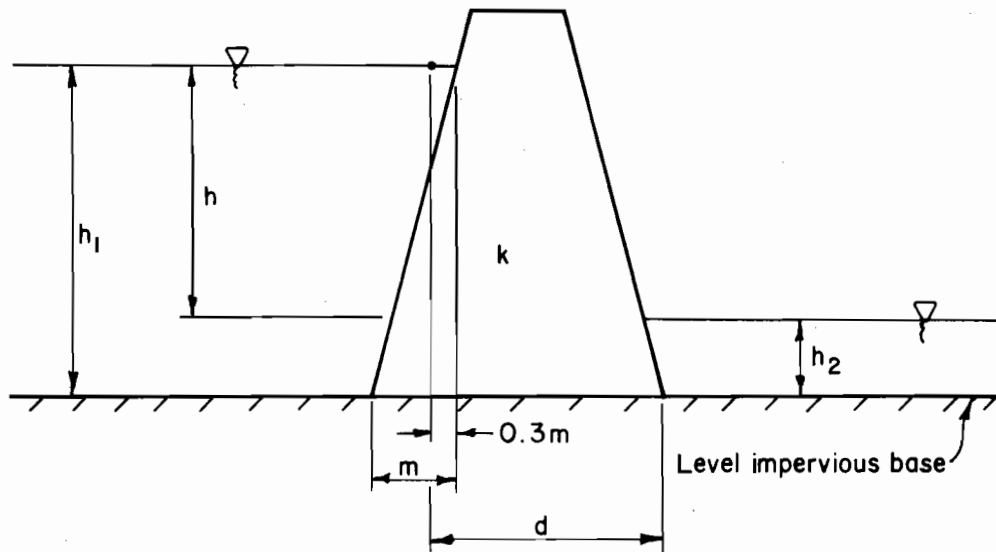

Flow through a narrow core or transformed section

$$\text{approximate } q = k \frac{h_1^2 - h_2^2}{2d}$$

Figure 8. Narrow core or transformed section where $d/h < 1$

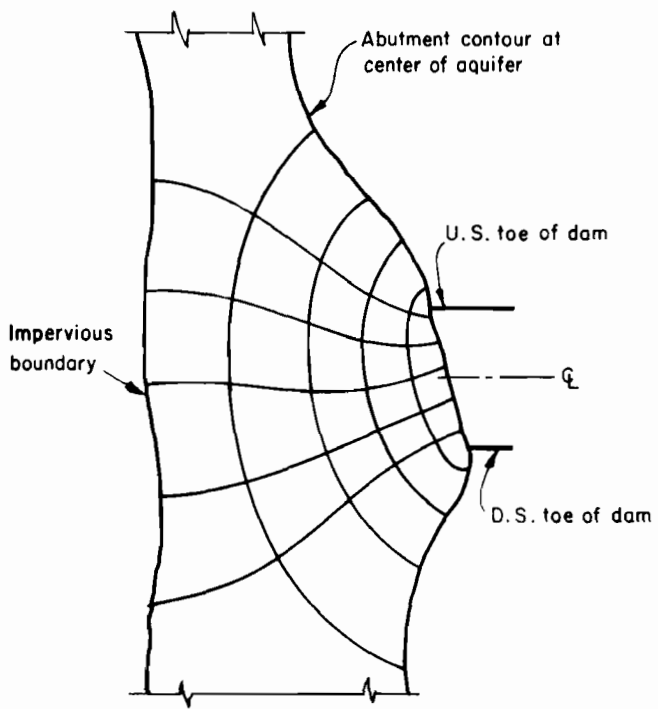

Flow net on horizontal plane at center of aquifer in abutment

(plan view)

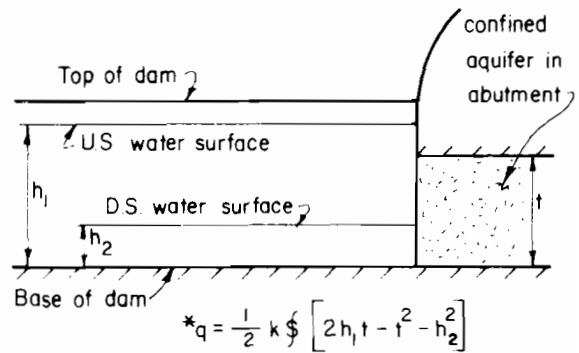
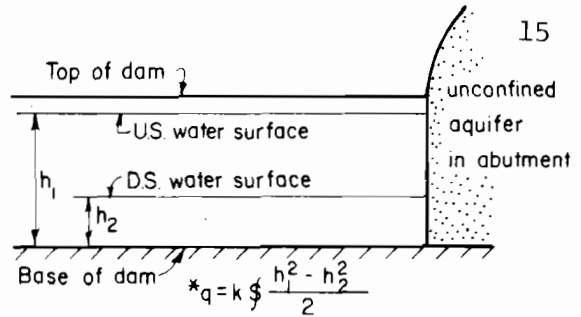

Elevations of near vertical abutment

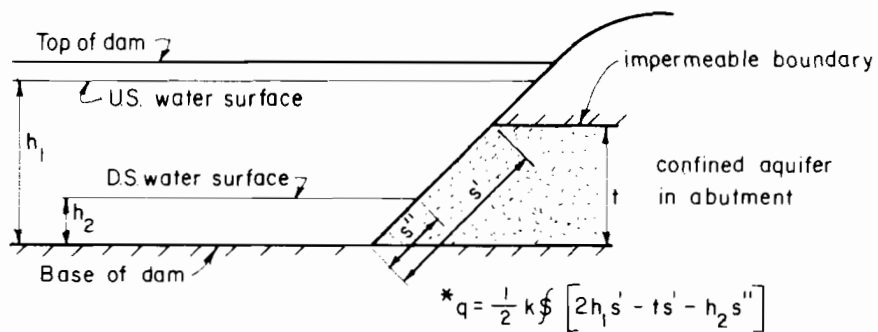
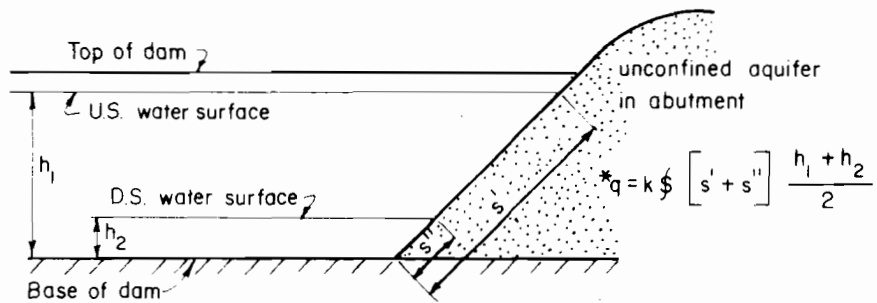

* q = discharge in one abutment for each case

§ = shape factor = N_f / N_d

Elevations of sloping abutment

Figure 9. Abutment seepage using horizontal flow net

From: Course titled "Seepage and ground water flow" presented by A. Casagrande of Harvard University.

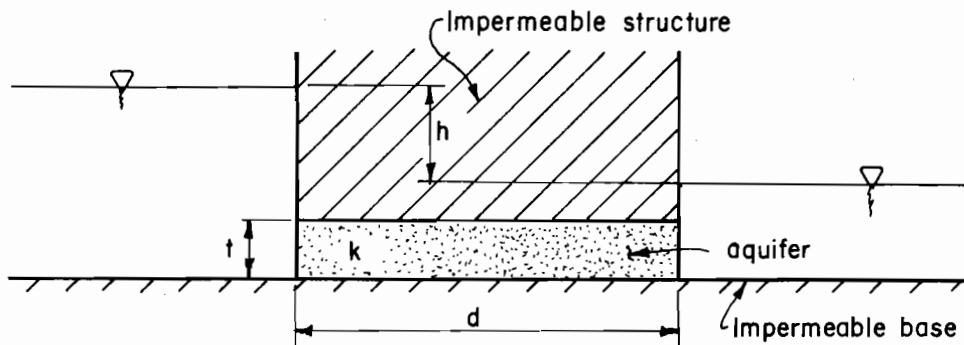

Compute seepage discharge per foot of length by Darcy's Law:

$$q = kiA$$

Where : k = permeability coefficient of the aquifer

$$i = \frac{h}{d} = \text{hydraulic gradient}$$

$A = t(1) = \text{cross sectional area of aquifer}$
for one foot length ($L=1$)

Figure 10 Confined aquifer of finite length
with submerged discharge face
(Darcy's law)

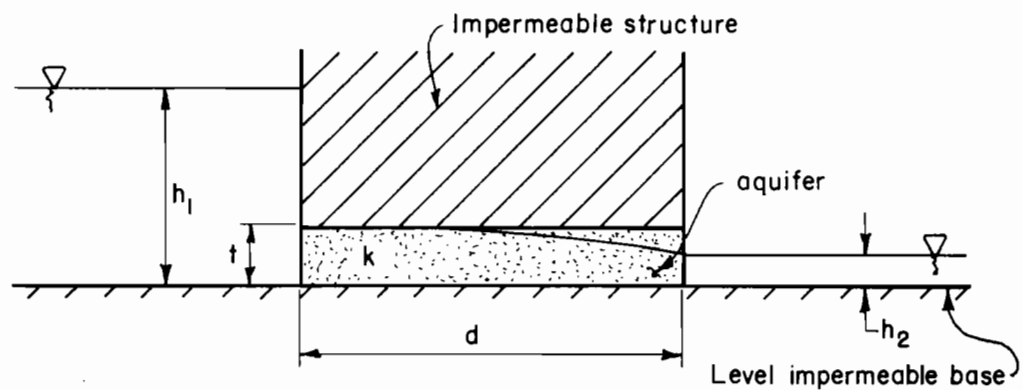

Compute discharge per foot of length by the following equation :

$$q = \frac{k}{2d} (2h_1 t - t^2 - h_2^2)$$

Where : k = permeability coefficient of the aquifer

Figure II. Combined aquifer of finite length with partially submerged discharge face (Darcy's law & Dupuit's assumption)

Symbols and terms used in blanket-aquifer calculations are shown in Figure 12.

Effective blanket lengths (L_1 and L_3) are calculated from the equation:

$$L_1, L_3 = \sqrt{(k_f/k_b)(z)(d)}$$

Pressure head (h_0) under the blanket at the downstream toe calculated from the equation:

$$h_0 = h \frac{L_3}{L_1 + L_2 + L_3}$$

The critical head (h_c) beneath the blanket at the downstream toe is calculated from the equation:

$$h_c = Z\gamma_{sub.}/\gamma_w.$$

The factor of safety relative to heaving of the blanket (F_h) at the downstream toe is calculated from the equation:

$$F_h = h_c/h_0$$

To be safe against uplift or blowout a suitable factor of safety is needed. A value of 1.5 to 2 is suggested with the higher values to be used on the more piping prone materials. When unsafe uplift conditions exist, the best solution is usually to provide controlled drainage at or under the downstream toe.

The quantity of seepage per foot of aquifer is obtained by applying Darcy's law to the pervious aquifer where the inlet is at the effective length of the upstream blanket and outlet is at the effective length on the downstream side. The seepage rate is obtained from the equation:

$$q_f = k_f \frac{h}{L_1 + L_2 + L_3} d$$

Blankets and aquifers are often discontinuous or having been eroded away in certain locations. These factors can have extremely adverse effects on the performance of the blanket to control seepage to acceptable amounts or to provide adequate stability.

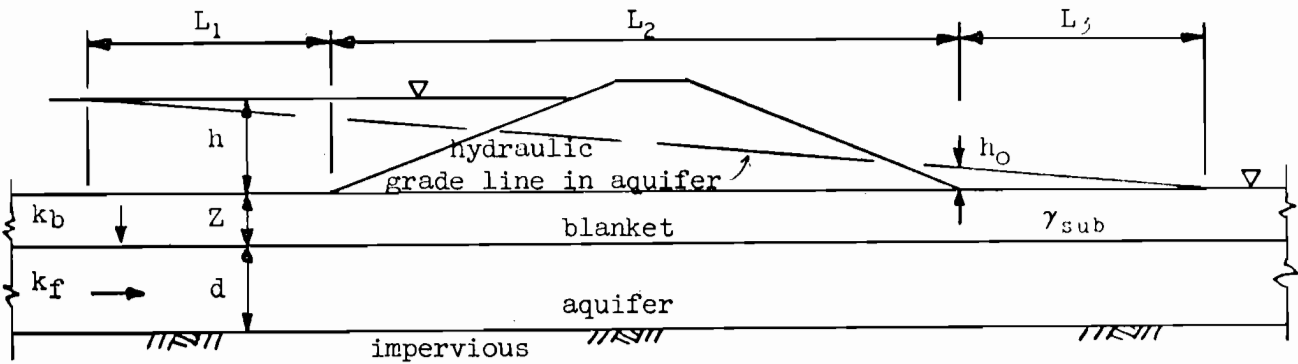

(a) Continuous blanket and aquifer

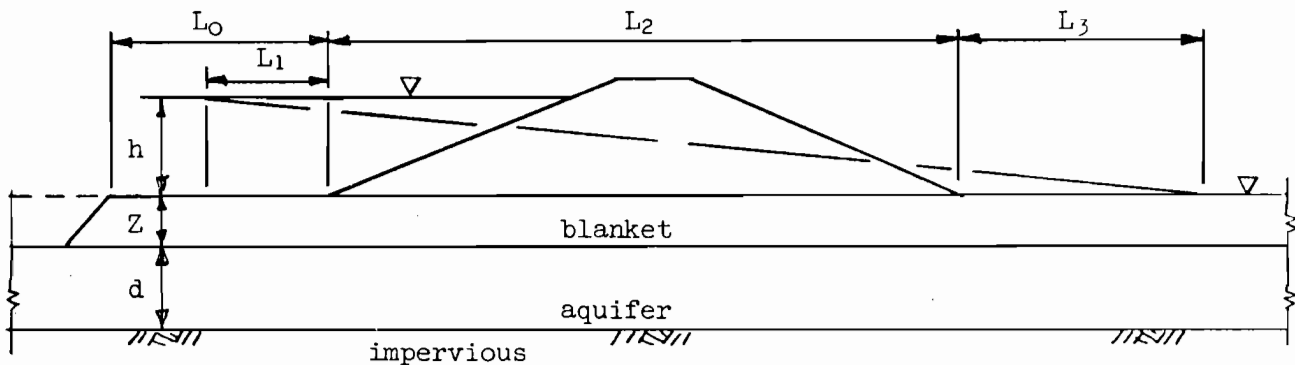

(b) Discontinuous upstream blanket - continuous aquifer

- L_1 = Effective length of upstream natural blanket
- L_2 = Length of embankment base
- L_3 = Effective length of downstream natural blanket
- L_0 = Length of discontinuous upstream blanket
- h = Net head to dissipate
- Z = Thickness of natural blanket
- d = Thickness of aquifer
- k_b = Permeability coefficient of blanket
- k_f = Permeability coefficient of aquifer
- γ_{sub} = Submerged unit weight of blanket
- h_0 = Pressure head under blanket at downstream toe of dam
- h_c = Critical head under blanket at downstream toe of dam
- F_h = Factor of safety relative to heaving at downstream toe
- γ_w = Unit weight of water (62.4 pcf)
- q_f = Rate of discharge through aquifer with unit length normal to the section.

Figure 12. Symbols and Terms used in Blanket-Aquifer Systems

Blankets can be added upon or be constructed completely from materials that have low permeability characteristics. Constructed blankets are usually compacted. The distance into the reservoir to which blanketing is needed can be determined. All the area within this limit must have a blanket and an aquifer of the thickness and permeability characteristics that will not exceed the assumed conditions used in the calculations.

Figure 13 provides a solution for determining the effective length of discontinuous blankets.

It should be noted that in most blanket-aquifer relationships the permeability coefficients of the blanket and aquifer are entered as a ratio, (k_f/k_b). These values are usually referred to in terms of this ratio, such as 25, 50, or 100: Meaning that the permeability of the aquifer is 25, 50, or 100 times as great as the permeability of the blanket.

The following procedure is recommended for determining the length to which a blanket must be provided in the upstream direction from the toe of the dam.

- a. Calculate the product $(Z)(d)$ and the ratio k_f/k_b , then determine L_1 for a continuous blanket using the equation. A conservative value of k_h/k_b should be used, i.e., the highest probable ratio.
- b. Calculate h_0 , h_c , and F_h from the given equations. The value of F_h should be equal to or greater than the minimum value established by criteria. If the value of F_h is less than the allowable, a drainage system may be used, the blanket thickness may be increased or the permeability coefficient of the blanket may be decreased by compaction.
- c. Calculate the quantity of seepage (q_f) using the appropriate equation. Compare the seepage quantity with the water budget and other considerations related to seepage loss. If the seepage quantity is excessive, a reduction can be realized by adding to the thickness of the blanket or by a reduction in the permeability coefficient of the blanket with additional compaction or other means. When these methods are used, steps a, b, and c are repeated before going to step d.

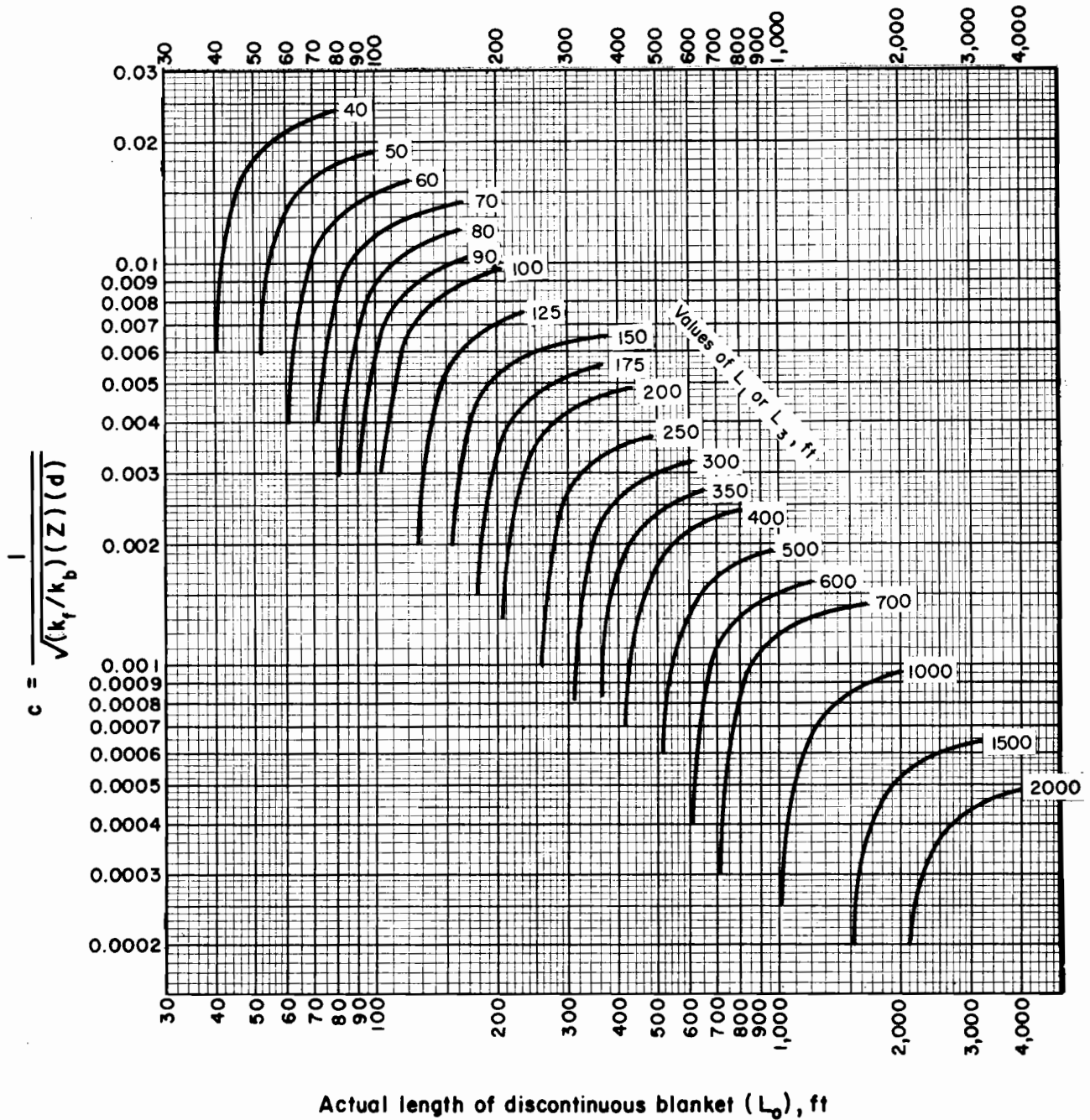

$$L_{1,3} = \frac{e^{2cL_0} - 1}{c(e^{2cL_0} + 1)}$$

Figure 13. Values of L_1 and L_3 for discontinuous natural blankets

- d. If the quantity of seepage is acceptable, calculate

$$\text{factor } c = \frac{1}{\sqrt{(k_f/k_b)(Z)(d)}}$$

- e. Enter Figure 13 with values of c and L_1 to obtain L_0 which is the distance from the upstream toe to where a discontinuity in the blanket will have no effect on the seepage or uplift values. This is the point beyond which a natural blanket may be removed in a borrowing operation.

It should be noted that if drainage is provided at the downstream toe or if a constructed blanket extends only in the upstream direction, the value of L_3 is zero. This method may be used for designing a compacted blanket over a pervious aquifer that has no natural blanket. The optimum length of a compacted upstream blanket for the purpose of reducing the seepage quantity can be estimated in the following manner.

- a. Assume several values of L_0 (the length of upstream blanket from the upstream toe of the dam or the core section of a zoned embankment.)
- b. Calculate $c = \frac{1}{\sqrt{(k_f/k_b)(Z)(d)}}$ from the design thicknesses and permeability rates determined for the constructed blanket and the natural aquifer.
- c. Enter Figure 13 with the assumed values of L_0 and the calculated value of c to obtain corresponding values of L_1 for each assumed value of L_0 .
- d. Calculate values of q_f for the values of L_1 ($L_3 = 0$ with no downstream blanket).
- e. Plot q_f vs. L_0 . The curve will indicate a rapid decrease in q_f for increasing values of L_0 up to a point where the curve flattens out indicating an optimum length. The blanket can be terminated at any point where the desired reduction in seepage is achieved. A drainage system is always recommended near the downstream toe to contain the seepage and direct it to the stream channel.

The procedures explained above are for homogeneous and isotropic conditions within the blanket and within the aquifer. Transformations can be made for a stratified blanket (multi-layered) a stratified aquifer or both stratified blanket and aquifer.



APPENDIX A

Appendix A contains examples for the various methods of analysis discussed



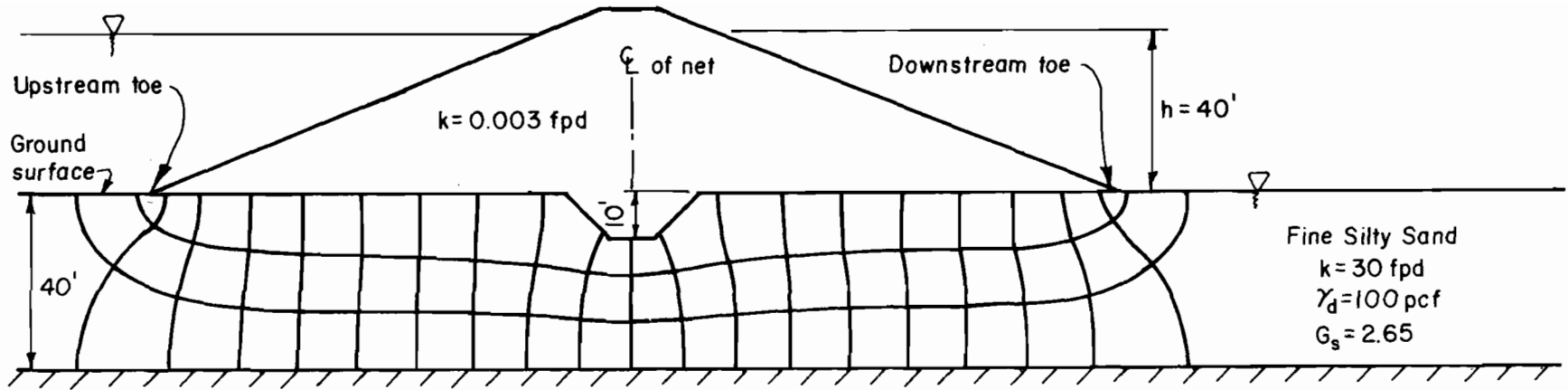

Determine the seepage discharge per foot of structure length through the foundation sand layer and check the potential for piping at the downstream toe.

- Construct the flow net according to procedures in Soil Mechanics Note No. 5, and calculate the shape factor $\xi = N_f/N_d = 3/20 = \underline{0.15}$
- $q = k h \xi = 30 \text{ fpd} (40 \text{ ft.}) (.15) = \underline{180 \text{ cfs/ft.}}$
- Calculate discharge gradient at the toe: $\Delta h = h/N_d = 40/20 = 2$; $\Delta \ell$ (measured) = 4 ft.; $i_d = \Delta h/\Delta \ell = 2/4 = 0.50$
- Calculate critical gradient: $J = \gamma_w i_c = \gamma_{sub}$.
 $i_c = \gamma_{sub}/\gamma_w = \gamma_d/\gamma_w (1 - 1/G_s) = 100/62.4(1 - 1/2.65) = \underline{1.0}$.
- Compare the critical gradient with the discharge gradient to check for piping potential.

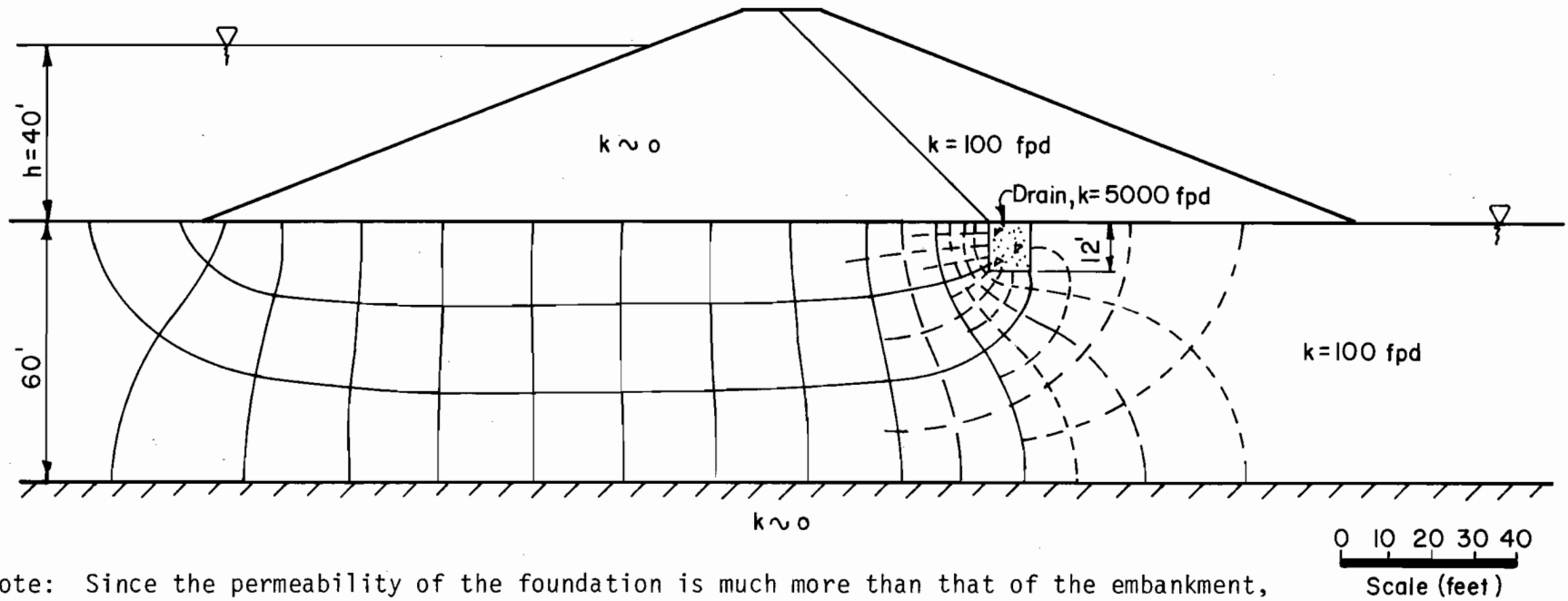

Note: Since the permeability of the foundation is much more than that of the embankment, construct the flow net for the foundation only.

Estimate the discharge to the foundation drain.

After subdivision, $N_f = 12$ and $N_d = 44$.

$$q = k h \frac{N_f}{N_d} = 100 \times 40 \times \frac{12}{44} = 1090 \text{ cfd/ft. of dam (total discharge per ft.)}$$

About 9.5 flow channels contact the drain.

$$\text{Discharge to the drain} = \frac{9.5}{12} \times 1090 = 860 \text{ cfd/ft. of dam length.}$$

Example 2. Discharge to a drain

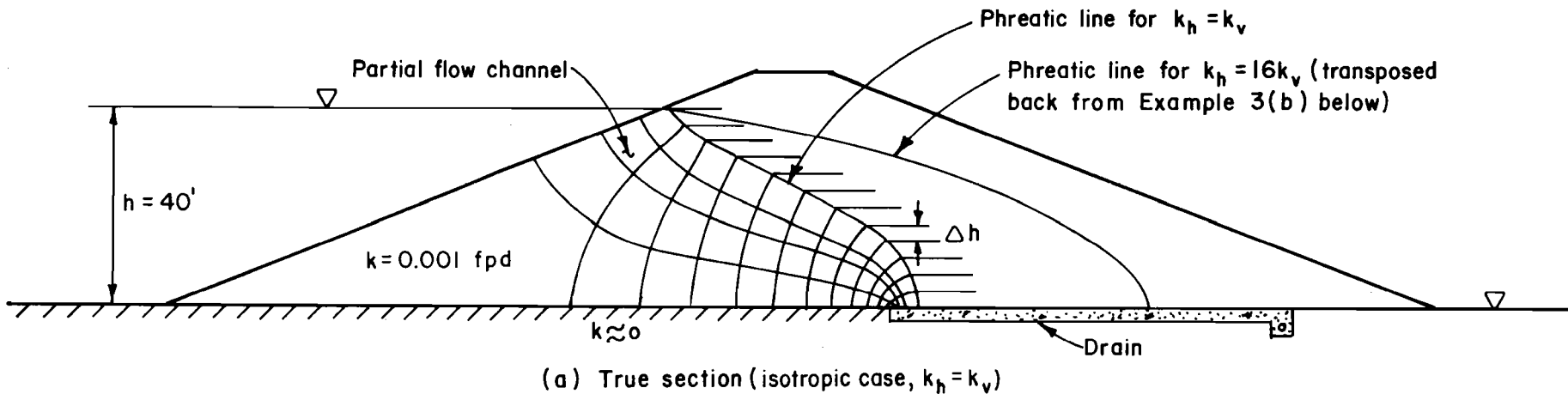

Determine the location of the phreatic line and calculate the seepage rate for the isotropic and anisotropic cases as indicated using a flow net.

For isotropic case $q = k h N_f/N_d = 0.001 \times 40 \times 3.7/12 = 0.012 \text{ cfd per foot of structure.}$

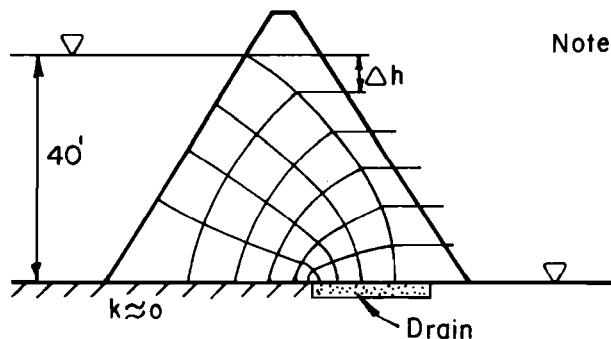

Note: Horizontal transformation factor =

$$\sqrt{\frac{k_v}{k_h}} = \sqrt{\frac{1}{16}} = 0.25$$

Assume $k_v = 0.001$, $k_h = 0.016$

$$k' = \sqrt{k_v k_h} = \sqrt{0.001(0.016)} = 0.004 \text{ fpd}$$

$$q = k' h \frac{N_f}{N_d} = 0.004 (40) \left(\frac{4}{6}\right) = 0.107 \text{ cfd per foot of structure}$$

Example 3. Effect of anisotropy of embankment on the phreatic line

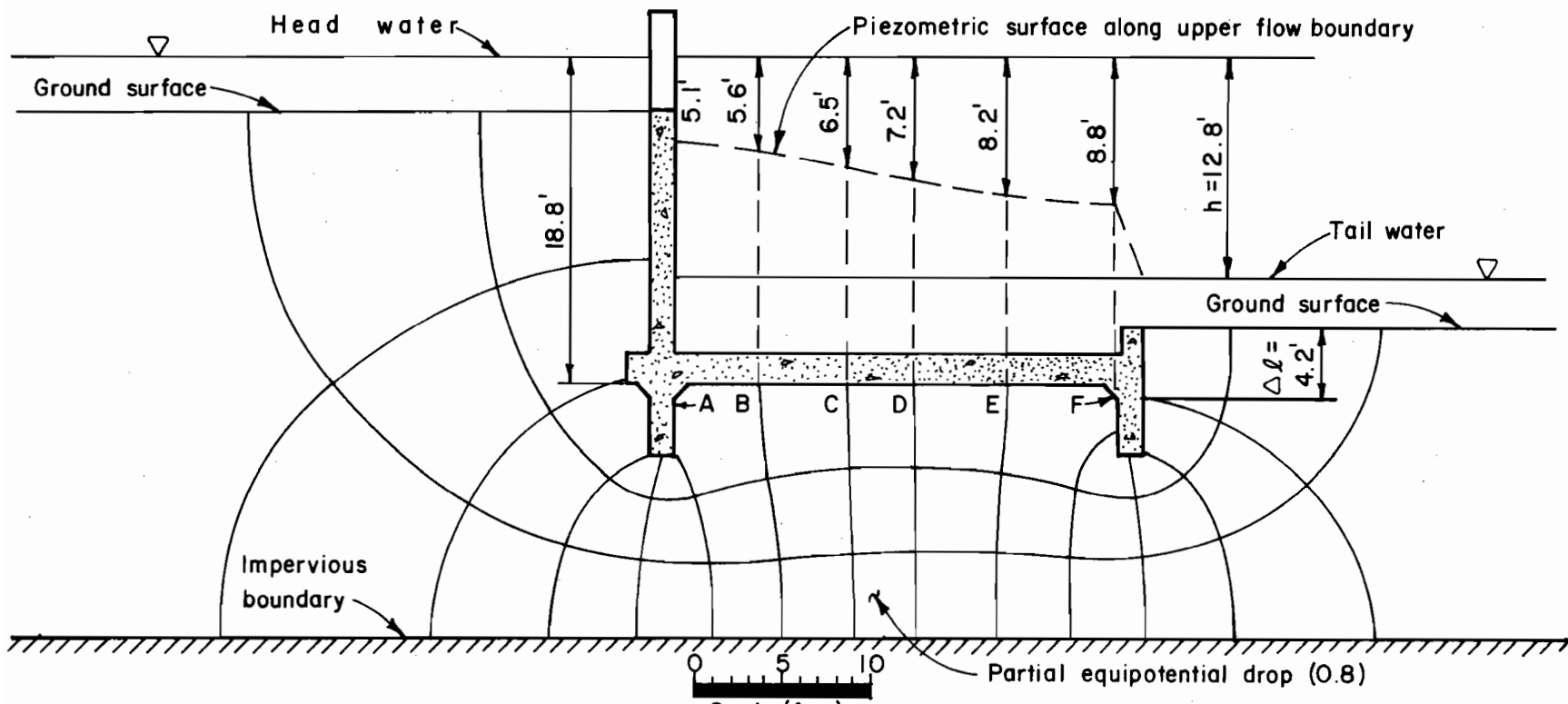

$$N_d = 13.8; \quad \Delta h = \frac{h}{N_d} = \frac{12.8}{13.8} = 0.93 \text{ ft.}$$

Point designation	No. of drops to point	Head loss = $(\Delta h \times \text{No. drops})$ (ft.)	Uplift pressure $(18.8' - \text{hd. loss}) \gamma_w$ (p.s.f.)
A	5.5	5.1	855
B	6.0	5.6	824
C	7.0	6.5	768
D	7.8	7.2	725
E	8.8	8.2	662
F	9.5	8.8	624

Discharge gradient at toewall and transverse sill:

$$i_d = \frac{\Delta h}{\Delta \ell} = \frac{0.93}{4.2} = 0.22$$

Example 4. Concrete drop spillway - base uplift and discharge gradient

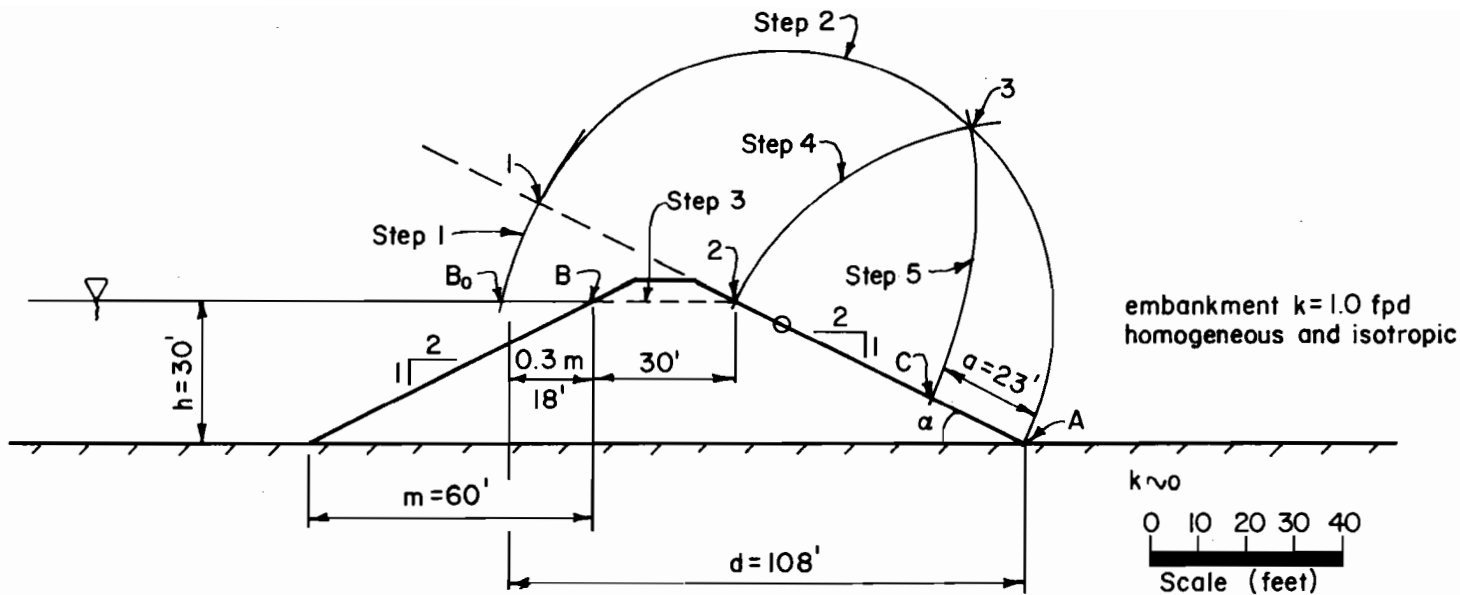

Determine the discharge point of the phreatic surface on the downstream face of the dam and the seepage quantity using the graphical methods and analytical solution on Figure 3.

A. Graphical Solution:

1. Determine m distance and plot $B_0 = 0.3$ m from point B.
2. Find the locations of points 1, 2, 3, and C following the steps given on Figure 3. Point C is the discharge point of the phreatic surface.
3. Scale the distance $A C = a = 23$ ft.
4. Determine α : $\tan \alpha = \frac{1}{2} = 0.5$ $\alpha = 26.56^\circ$
5. Calculate seepage discharge = $k a \sin^2 \alpha$
 $= 1.0 (23)(.4472)(.4472) = 4.60$ cfd/ft. length

B. Analytical Solution

1. Compute $a = \sqrt{a^2 + d^2} - \sqrt{d^2 - h^2 \cot^2 \alpha} = \sqrt{12564} - \sqrt{8064} = 22.3$ ft.
2. Compute $q = k a \sin^2 \alpha = 1.0(22.3)(.4472)^2 = 4.46$ cfd/ft. length.

Example 5. Phreatic Line - Graphical Solution

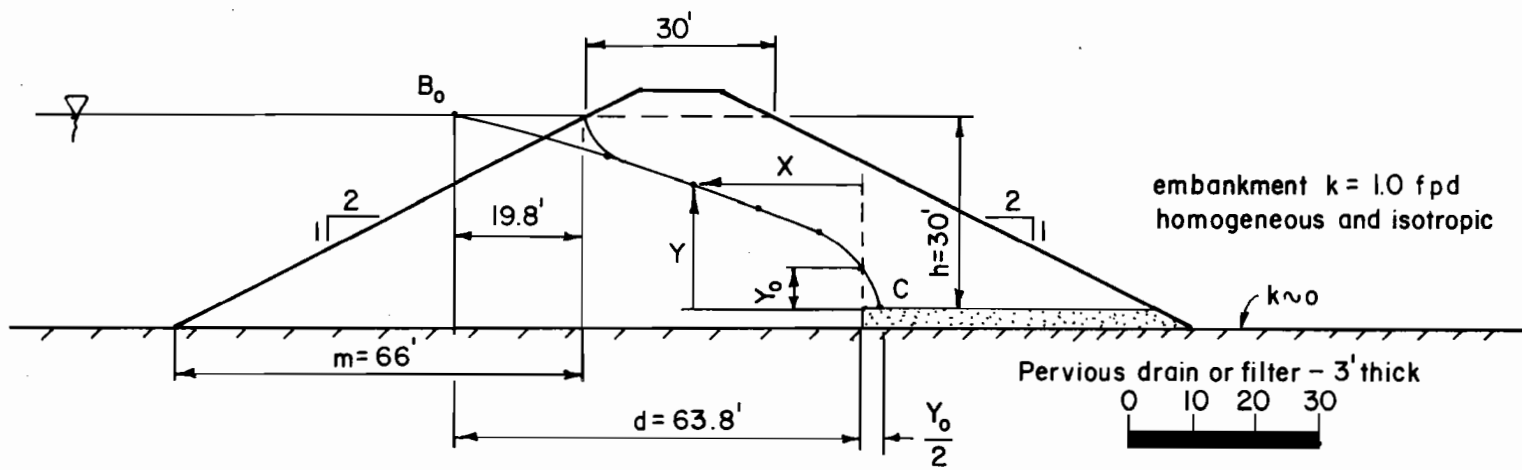

Determine the phreatic surface and seepage rate per foot length normal to the section that discharges into the blanket drain and compare with example 5 having no drain.

1. Determine $m = 2(33) = 66$ ft.; $0.3(66) = 19.8$ ft.; $d = 63.8$ ft.
2. Calculate $y_0 = \sqrt{h^2 + d^2} - d = \sqrt{900 + 4070} - 63.8 = 6.70$ ft.
3. Determine Parabolic Equation: $x = \frac{y^2 - y_0^2}{2y_0} = \frac{y^2 - (6.70)^2}{2(6.70)} = 0.0746y^2 - 3.35$
4. Calculate values of x and y : $(y = 6.70, x = 0)$; $(y = 12, x = 7.39)$; $(y = 16, x = 15.7)$; $(y = 20, x = 26.5)$; $(y = 24, x = 39.6)$; $(y = 30, x = 63.8)$.
5. Plot parabola and sketch ingress transition.
6. Calculate the seepage rate: $q = k y_0 = 1.0 \times 6.70 = 6.70$ cfd per foot of structure normal to the cross section.
7. Compare with Example 5: $6.70 > 4.60$. Seepage increases with drainage.

Example 6. Phreatic Line - Embankment with Drain

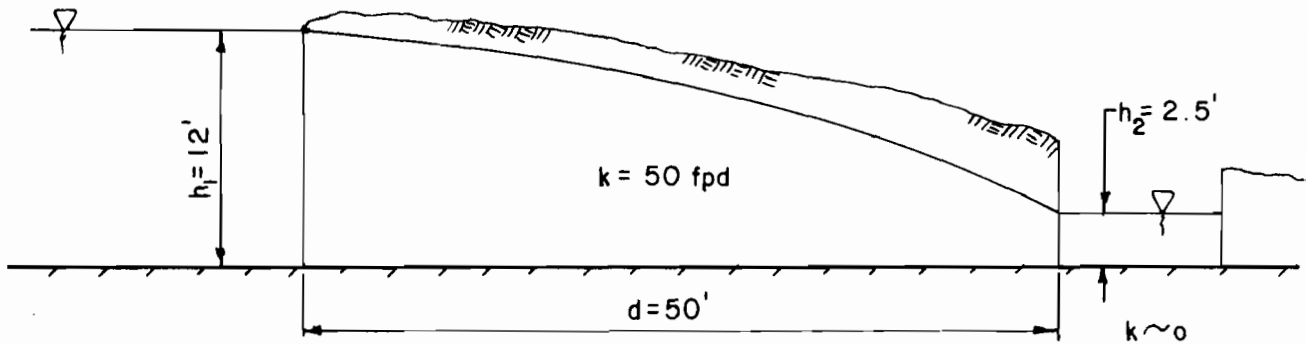

A drainage ditch parallels a river to intercept seepage and prevent raising the ground water level in the lower farm land. Pumping stations will be installed at 1000 foot intervals to return the seepage flows to the river. Determine the needed capacity of each pumping station for the condition shown.

1. From Figure 7 $q = k \frac{h_1^2 - h_2^2}{2d}$

$$q = 50 \frac{(12)^2 - (2.5)^2}{100} = 0.50 (144 - 6.25) = 68.9 \text{ cfd per foot of length}$$

2. Pumping capacity in gpm

$$q = \frac{68.9 \text{ cfd} (7.48 \text{ gal/cu ft})}{1440 \text{ min/day}} = 0.358 \text{ gpm per foot of length}$$

for 1000-foot length: $Q = qL = 0.358(1000) = 358 \text{ gpm}$

Example 7 - Unconfined aquifer with vertical inlet and outlet faces
(Dupuit's Assumption)

A 200 ft. long by 50 ft. wide excavation is to be made parallel to a stream. Soils investigation revealed that a uniform deposit of medium sand, 10 ft. to 12 ft. thick, overlies a clayey silt. Permeability of the sands ranges from 1 fpd. to 5 fpd. The clayey silt is relatively impervious. The stream level is normally below the contact between the sands and the clayey silt and groundwater levels were slightly above the contact. During the wet season, the stream may flow half full for several weeks with occasional full bank flow. The excavation will extend into the clayey silt. Estimate discharge into the excavation for the full bank flow conditions.

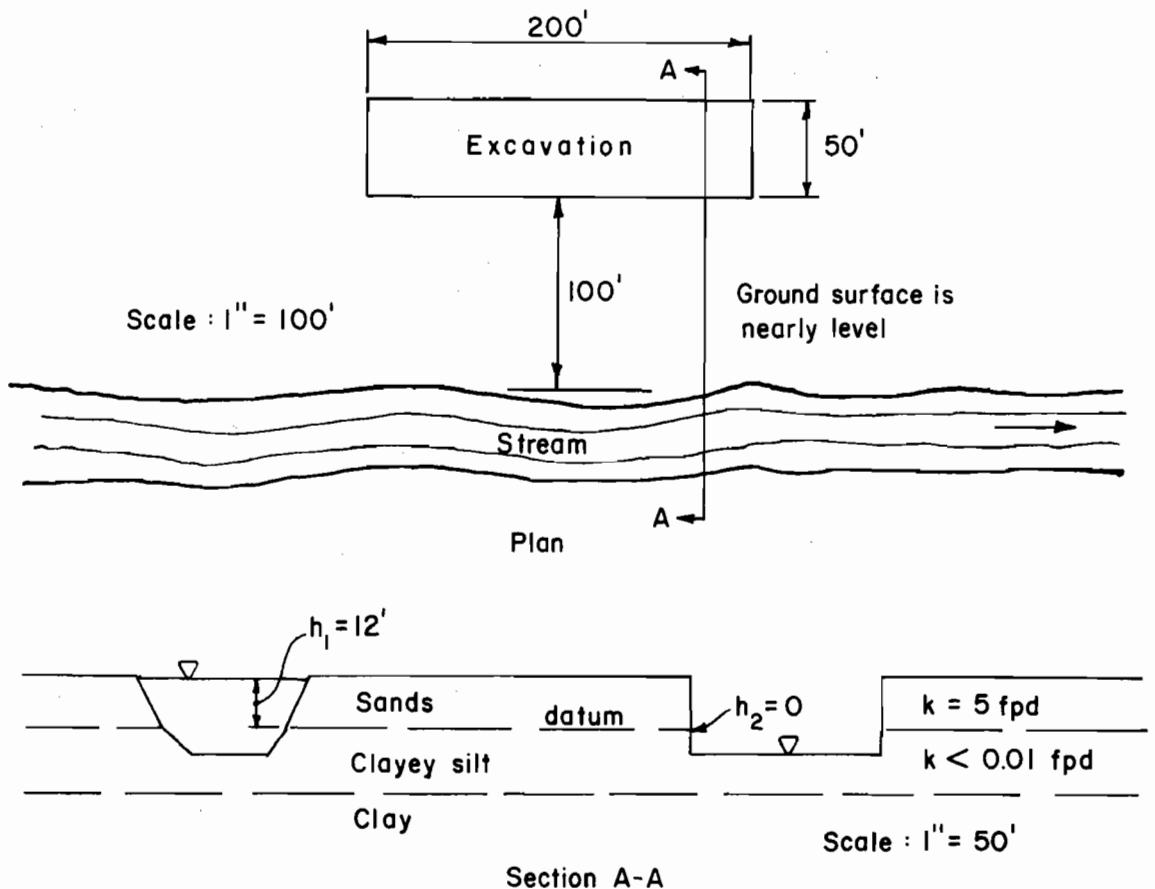

Construct a flow net in plan and combine with the Dupuit equation. In this case, the Dupuit assumption is valid.

$$Q = k \int \frac{h_1^2 - h_2^2}{2}$$

- k = coefficient of permeability
- \int = shape factor from flow net
- h_1 = source head, above datum
- h_2 = tailwater head, above datum

Example 8. Flow to an Excavation

Horizontal Flow Net

$$N_f = 9.5 \times 2 = 19$$

$$N_d = 4$$

$$\xi = \frac{N_f}{N_d} = \frac{19}{4} = 4.75$$

$$k = 5 \text{ fpd}$$

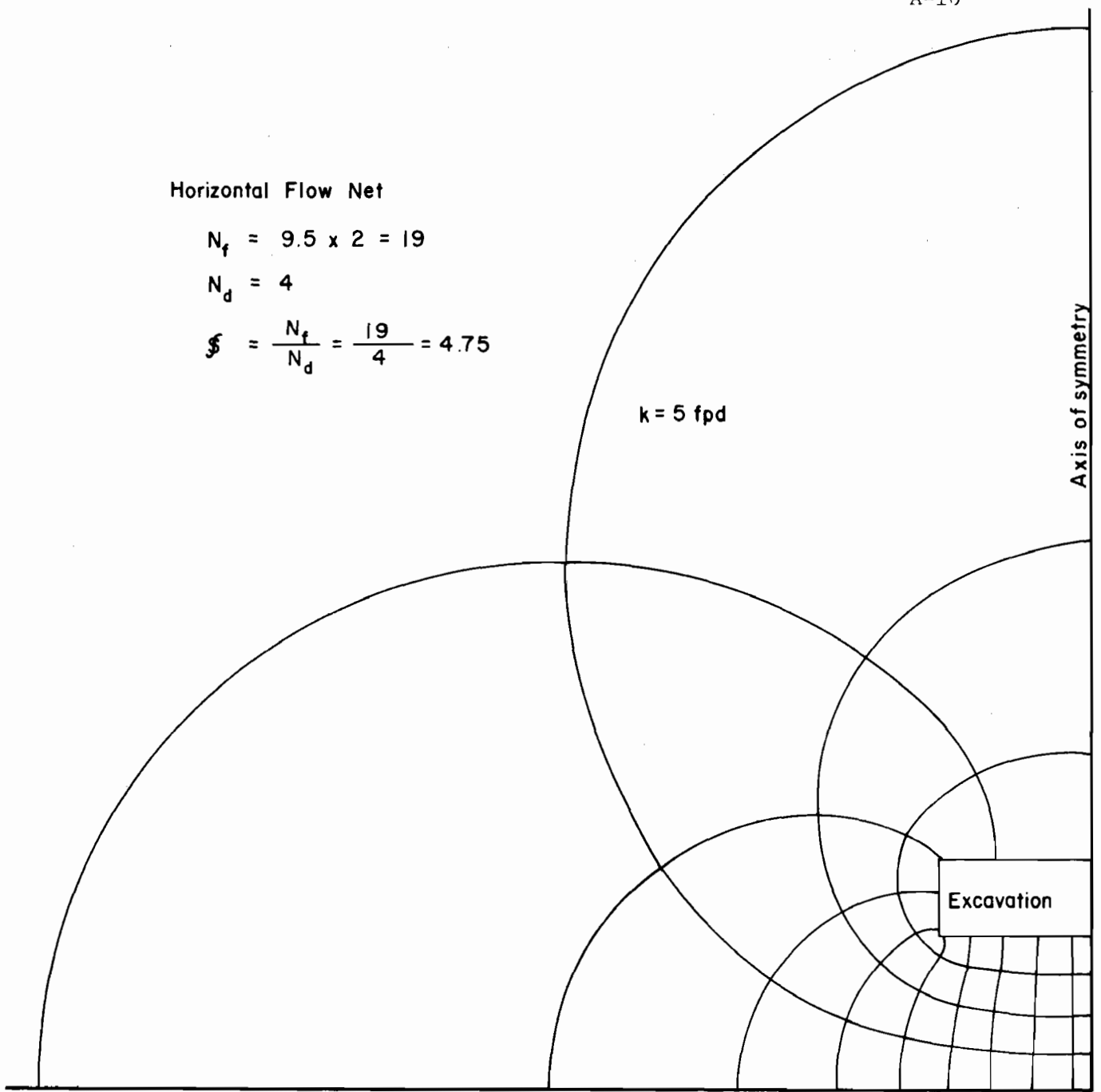

Edge of stream

Plan view

Scale : 1" = 100'

$$Q = k \xi \left[\frac{h_1^2 - h_2^2}{2} \right] = 5 \times 4.75 \times \frac{12^2}{2} = 1710 \text{ cfd}$$

An embankment core with $k = 0.1 \text{ fpd}$ is placed on an impervious foundation. Permeability of shell material is 100 fpd . Determine the seepage rate through the core by: (1) flow net, (2) phreatic line, and (3) unconfined aquifer, Dupuits Assumption.

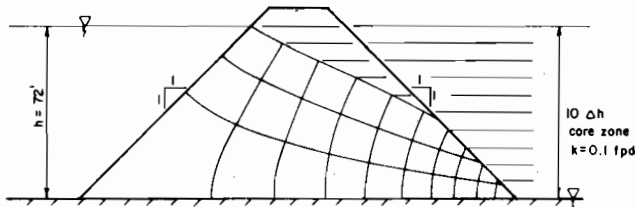

- Flow Net. Shape factor $\$ = N_f/N_d = 3/10 = 0.300$
 $q = h k \$ = (72)(0.1)(.30) = 2.16 \text{ cfd per foot of length}$

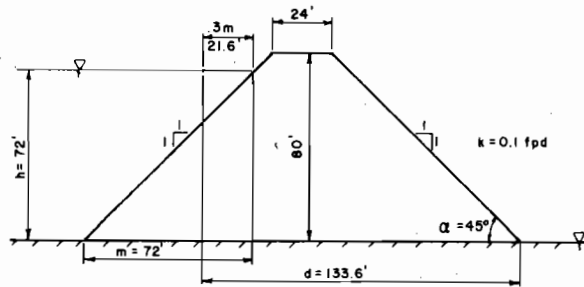

- Phreatic Line: $a = \sqrt{h^2 + d^2} - \sqrt{d^2 - h^2 \cot^2 \alpha}$
 $= \sqrt{5184 + 17849} - \sqrt{17849 - 5184(1)} = 151.8 - 112.5 = 39.3 \text{ ft.}$
 $q = k a \sin^2 \alpha = (0.1)(39.3)(.707)(.707) = 1.97 \text{ cfd per foot of length}$

- Unconfined aquifer - Dupuit's Assumption:
 $q = k \frac{h^2}{2d} = (0.1) \frac{72^2}{(2) 133.6} = 1.94 \text{ cfd per foot of length}$

Same as Example 9A, except that the core material is anisotropic; $k_v = 0.33$ fpd and $k_h = 3.0$ fpd. Determine the seepage rate through the core by: (1) flow net, (2) phreatic line development does not apply because d/h is less than 1.0, and (3) unconfined aquifer, Dupuits Assumption.

All horizontal distances are reduced by a factor of $\sqrt{k_v/k_h} = \sqrt{1/3 \div 3} = 0.33$
Coefficient of permeability for computing discharge

$$k' = \sqrt{(k_v) k_h} = \sqrt{1/3(3)} = 1.0 \text{ fpd}$$

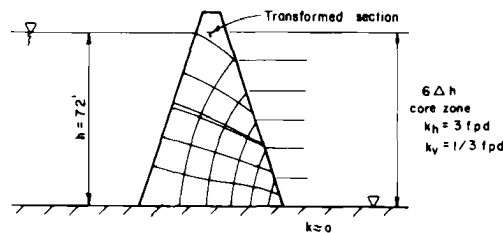

1. Flow Net

$$\text{Shape factor } S = \frac{N_f}{N_d} = \frac{5.15}{6} = 0.858$$

$$q = k' h S = 1.0(72)(.858) = 61.8 \text{ cfd per foot of length}$$

2. Phreatic Line - does not apply since $h > d$.

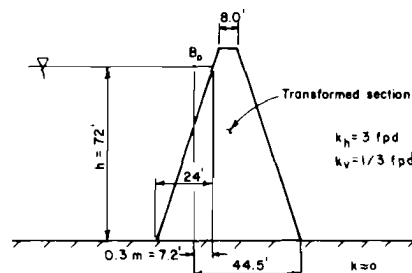

3. Unconfined aquifer - Dupuit's Assumption

$$q = k' \frac{h^2}{2d} = (1) \frac{72^2}{(2)44.5} = 58.3 \text{ cfd per foot of length}$$

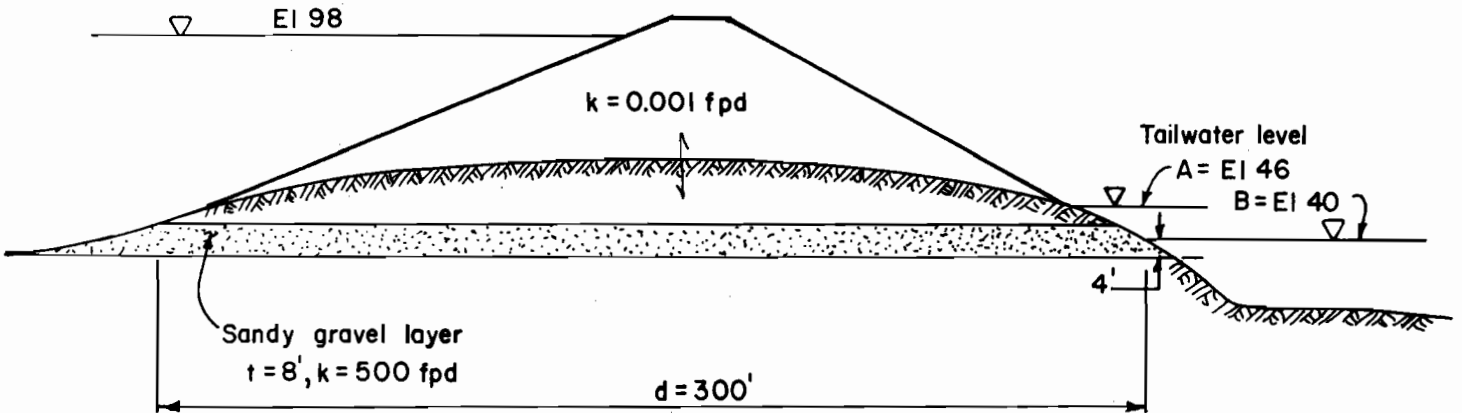

Determine the total seepage quantity in cfs through the permeable layer of sandy gravel for a 400-foot long reach of dike having the conditions shown. Calculate the seepage for tailwater levels A and B.

For tailwater level A:

Use Darcy's Law - see figure 10

$$q = k i A \quad i = h/d = 52/300 = 0.173$$

$$A = (8)(1) = 8 \text{ sq. ft.}$$

$$q = k i A = (500)(0.173)(8) = 692 \text{ cfd per foot of length}$$

$$\text{for 400 ft. length } Q = q L = 692 \frac{\text{cfd}}{\text{ft}} (400 \text{ ft.})/86,400 \text{ sec per day} = 3.2 \text{ cfs}$$

For tailwater level B:

Use Darcy's Law and Dupuit's Assumption - see figure 11.

$$h_1 = 98 - 40 + 4 = 62 \text{ ft.}$$

$$h_2 = 4 \text{ ft.}; \quad t = 8 \text{ ft.}$$

$$q = (k/2d)(2 h_1 t - t^2 - h_2^2)$$

$$= (500/600) [2(62)(8) - (8)^2 - (4)^2] = 760 \text{ cfd per foot of length}$$

$$\text{for 400 ft. length: } Q = q L = 760 \frac{\text{cfd}}{\text{ft}} (400 \text{ ft.})/86,400 \text{ sec per day} = 3.5 \text{ cfs}$$

Example 10. Confined aquifer - Finite length

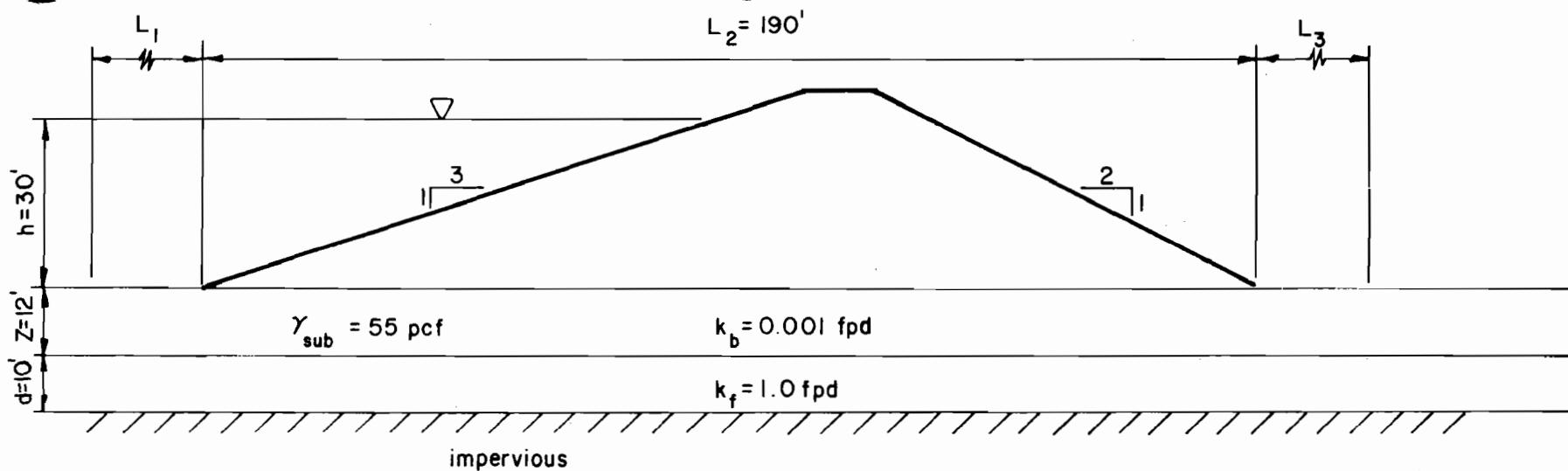

Determine the quantity of seepage (q_f) per foot of embankment length and the factor of safety relative to heaving at the downstream toe.

1. Calculate $k_f/k_b = 1/.001 = 1000$
2. Calculate $L_1 = L_3 = \sqrt{(k_f/k_b)(d)(Z)} = \sqrt{(1000)(10)(12)} = \sqrt{120,000} = 346$ feet
3. Calculate $q_f = k_f \frac{h}{L_1 + L_2 + L_3} d = 1 \frac{30}{882} 10 = 0.34$ cfd per foot of structure
4. Calculate $h_0 = h \frac{L_3}{L_1 + L_2 + L_3} = 30 \frac{346}{346 + 190 + 346} = 30(0.392) = 11.8$ feet
5. Calculate $h_c = Z \gamma_{sub}/\gamma_w = \frac{12(55)}{62.4} = 10.6$ feet
6. Determine factor of safety, $F_h = h_c/h_0 = 10.6/11.8 = 0.89$; unsafe, provide drainage at toe and recalculate q_f using $L_3 = 0$.

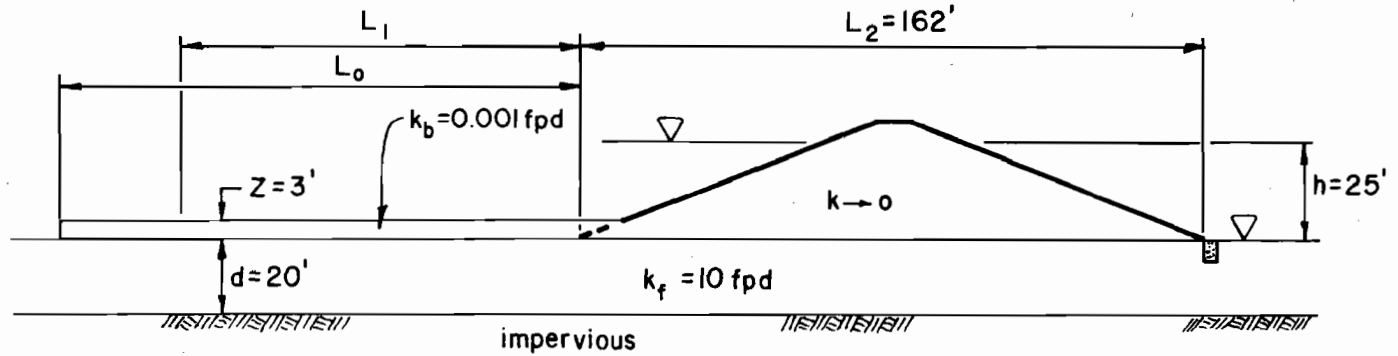

Estimate the length of the compacted blanket for optimum reduction of q_f .

1. $c = \frac{1}{\sqrt{(k_f/k_b)(Z)(d)}} = \frac{1}{\sqrt{10,000(3)(20)}} = 0.0013$
2. $q_f = \frac{k_f d h}{L_1 + L_2} = \frac{(10)(20)(25)}{L_1 + 162} = \frac{5000}{L_1 + 162} \quad (L_3 = 0)$
3. Assume values of L_0 , with $c = 0.0013$, obtain values of L_1 from figure 14. Calculate values of q_f . Plot q_f vs. L_0 .
4. The optimum length of compacted upstream blanket appears to be about 300 feet. Then, must ascertain whether or not a water loss of about 11 cfd/ft of length can be tolerated.

L_0 (ft)	L_1 (ft)	$L_1 + 162$ (ft)	$q_f = \frac{5000}{L_1 + 162}$ (cfd/ft of dam length)
0	0	162	30.9
100	100	262	19.1
200	200	362	13.8
300	290	452	11.1
400	355	517	9.7
500	420	582	8.6
900	635	797	6.3

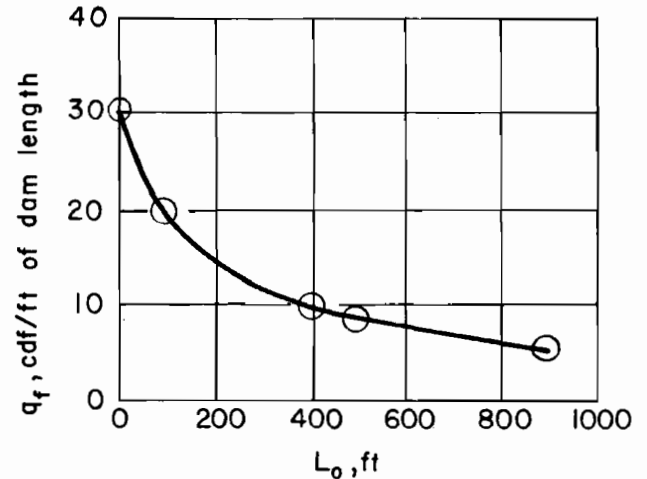

Example 12. Constructed Upstream Blanket