

U. S. Department of Agriculture
Soil Conservation Service
Engineering Division

Technical Release No. 42
Design Unit
December, 1969

SINGLE CELL RECTANGULAR CONDUITS
CRITERIA AND PROCEDURES FOR STRUCTURAL DESIGN

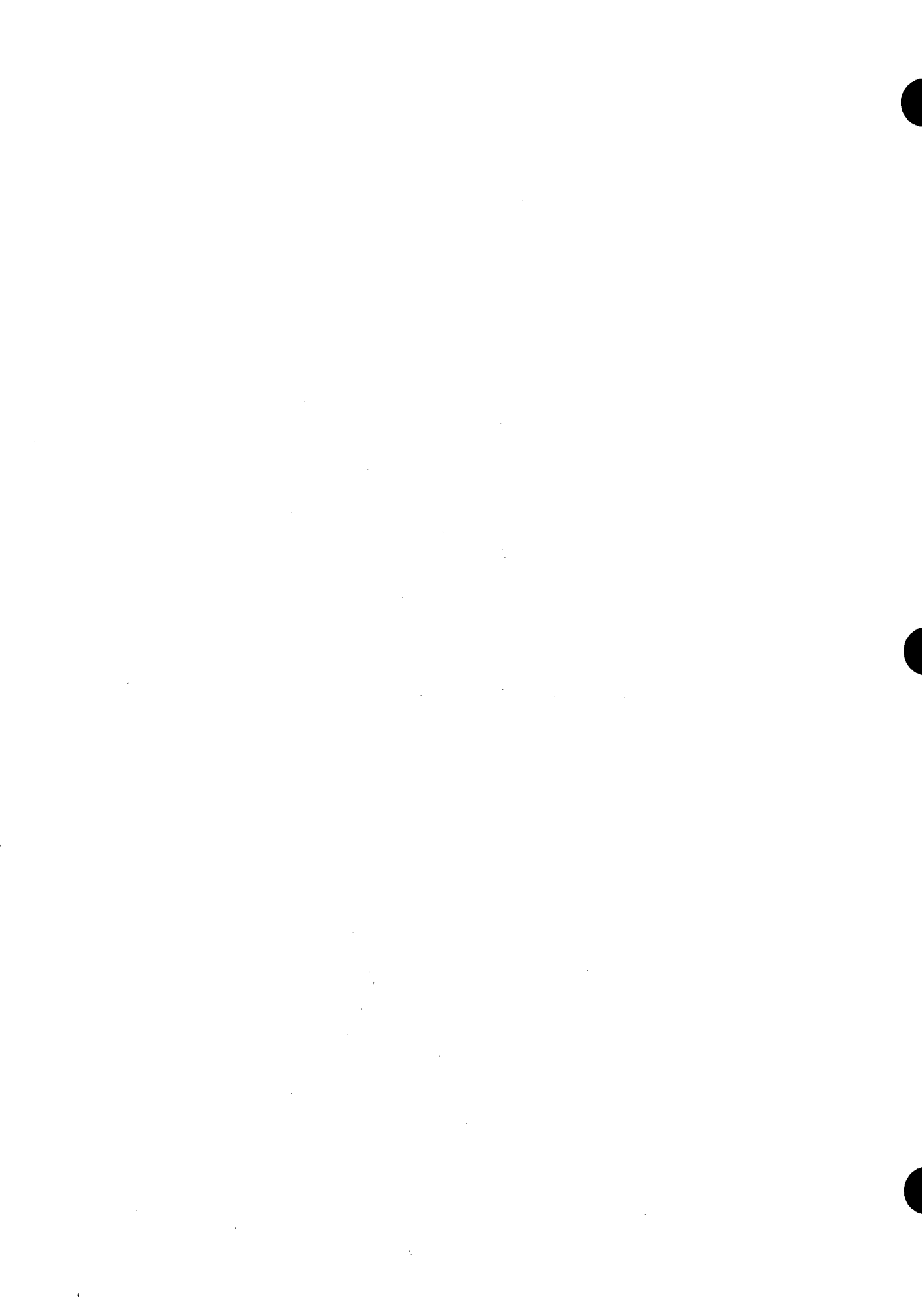

PREFACE

This technical release presents the criteria and procedures established for the structural design of single cell rectangular conduit cross sections. The criteria for these designs has developed over a period of years and has been discussed at various Design Engineers' meetings.

A preliminary set of designs obtained as computer output, was presented and discussed at the Engineering and Watershed Planning Unit-Washington Staff Design Consultation in Columbus, Ohio during July 14-18, 1969. Subsequently, a draft of the subject technical release dated August 14, 1969, was sent to the Engineering and Watershed Planning Unit Design Engineers for their review and comment.

This technical release was prepared by Mr. Edwin S. Alling of the Design Unit, Design Branch at Hyattsville, Maryland. He also wrote the computer program.

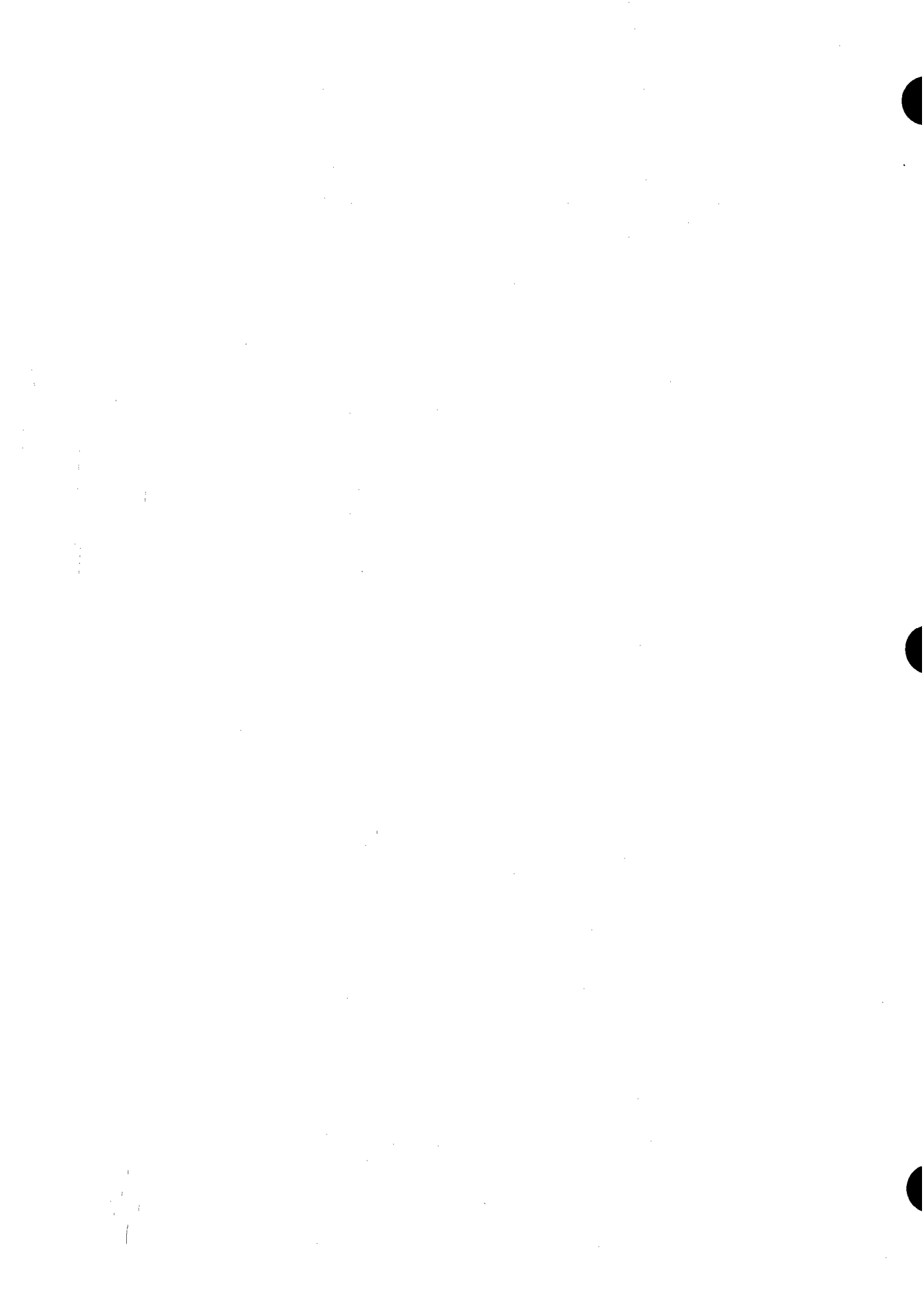

TECHNICAL RELEASE
NUMBER 42

SINGLE CELL RECTANGULAR CONDUITS
CRITERIA AND PROCEDURES FOR STRUCTURAL DESIGN

	<u>Page</u>
PREFACE	
NOMENCLATURE	
Computer Designs	1
Section Designed	1
Loads Specified by User	1
Design Mode	3
Loads on Rectangular Conduits	5
External Loads	5
Conduits on earth foundations	5
Conduits on rock foundations	6
Internal Water Loads	7
Basic Sets of Loads	8
Methods of Analysis for Indeterminate Moments	9
General Considerations	9
Dissymmetry of Sidewalls	10
Consideration that $t_b \geq (t_t + 1)$	11
Consideration that $t_{sb} > t_{st}$	11
Slope Deflection Equation	12
Slope Deflection Method	13
Design Criteria	16
Slab Thicknesses Required by Shear	17
Location of Critical Section for Shear	17
Design of Top Slab	18
Design of Sidewall	19
Conduits founded on earth, without internal water loads	19
Conduits founded on rock, without internal water loads	20
Convergence procedure - conduits on rock	21
Limit of shear criteria	22
Conduits with internal water loads	22
Summary shear design of sidewall thickness	24
Design of Bottom Slab	24
Summary of Shear Design	25

Analyses of Corner Moments	27
Unit Load Analyses	27
Evaluation of External Load Corner Moments	28
Analyses for Internal Water Loads	28
Sense of Corner Moments	29
Steel Required by Combined Bending Moment and Direct Force	31
Treatment of Bending Moment and Direct Force	31
Usual case, direct force at large eccentricity	31
Unusual case, direct compressive force at small eccentricity	32
Unusual case, direct tensile force at small eccentricity	33
Load Combinations Producing Maximum Required Areas	34
Maximum moment plus associated direct force	34
Maximum direct force plus associated moment	36
Procedure at a Section	37
Location 4 - negative bending moment with loading B1-IC#3	37
Location 6 - negative bending moment with loading B1-IC#3	38
Location 1 - positive bending moment with loading B2-IC#1	39
Location 7 - positive bending moment with loading B3-IC#2	40
Bottom slab, section at midspan - maximum direct compression	41
Bottom slab, section at midspan - maximum direct tension	42
Anchorage of Positive Steel	43
Positive Steel at Face of Support	43
Positive Steel at Corner Diagonals	43
Top corner diagonal	44
Bottom corner diagonal	45
Spacing Required by Flexural Bond	47
Relation to Determine Required Spacing	47
Load Combinations Producing Minimum Required Spacing	47
Procedure at a Section	48
Location 1 - with loading B1-IC#1	48
Location 1 - with loadings B2-IC#1 and B3-IC#1	48
Location 3 - with loading B3-IC#0	50
Location 4 - with loadings B1-IC#1 and B1-IC#2	50
Summary of Design	51
Appendix A	53
Appendix B	55

Figures

Figure 1	Conduit cross section and steel layout.	2
Figure 2	Load combinations producing maximum values at critical locations.	6
Figure 3	Treatment of internal water loads.	7
Figure 4	Assumed variation in moment of inertia.	9
Figure 5	Conduit spans and member thicknesses.	10
Figure 6	Unequal slab thicknesses.	11
Figure 7	Sidewall batter.	11
Figure 8	Development of Slope Deflection Equation.	12
Figure 9	Designations for analyses.	13
Figure 10	Location of critical shear.	17
Figure 11	Loads for shear thicknesses design of top slab.	18
Figure 12	Load distributions and shear diagrams for same total lateral load, W_s .	19
Figure 13	Sidewall shear, conduits on rock foundation.	20
Figure 14	Partial sidewall shear diagram.	20
Figure 15	Possible sidewall shear diagrams with V_{ex} included.	22
Figure 16	Loading for sidewall thickness, control from top.	23
Figure 17	Loading for sidewall thickness, control from bottom.	23
Figure 18	Loads for shear thickness of bottom slab.	24
Figure 19	Loadings for unit load analyses.	27
Figure 20	Fixed end moments for hydrostatic loading.	29
Figure 21	Sense of moments from Slope Deflection solution.	29
Figure 22	Range of values of moment and direct force.	31
Figure 23	Moments in top slab with loading B1-IC#3.	37
Figure 24	Components of direct force in top and bottom slabs with loading B1-IC#3.	38
Figure 25	Moment and direct force in sidewall with loading B1-IC#3.	39
Figure 26	Moments in top slab with loading B3-IC#1.	39
Figure 27	Components of direct force in top and bottom slabs with loading B2-IC#1	40
Figure 28	Moments in sidewall with loading B3-IC#2.	41
Figure 29	Moments in bottom slab with loading B1-IC#3.	42
Figure 30	Existence of tension in bottom steel.	43
Figure 31	Top corner geometry.	44
Figure 32	Resultants on top corner diagonal.	44
Figure 33	Points of inflection in top slab with loading B1-IC#1.	48
Figure 34	Points of inflection with loadings B2-IC#1 and B3-IC#1.	50
Figure 35	Summary flow chart of design process.	51

Tables

Table 1	Loadings for midspan moments.	34
Table 2	Loadings for moments at face of supports.	35
Table 3	Additional loadings for face moments.	36
Table 4	Loadings for maximum direct forces.	37
Table 5	Loadings for tension in bottom corner inside steel.	45
Table 6	Loadings for flexural bond.	49

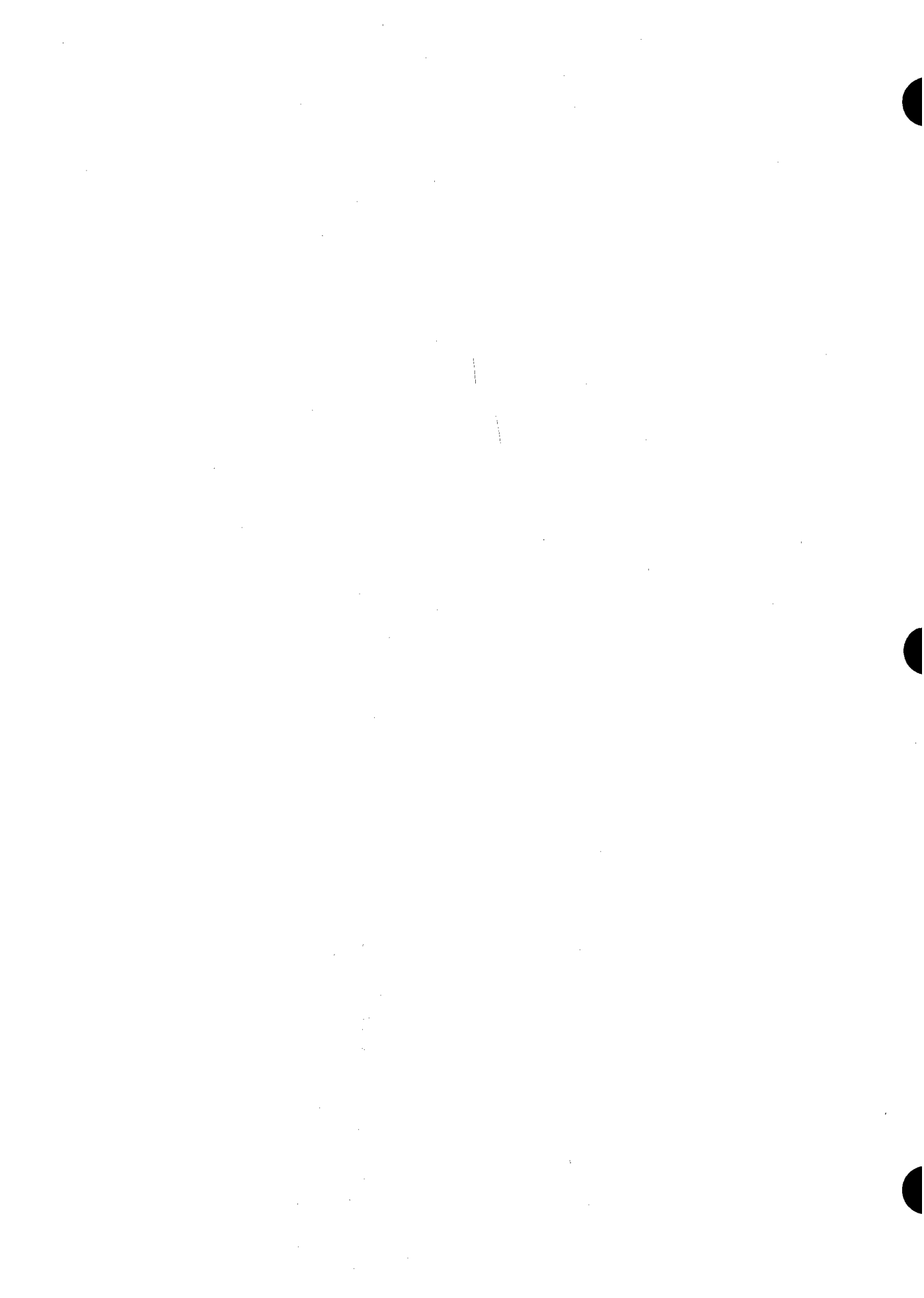

NOMENCLATURE

Not all nomenclature is listed. Hopefully, the meaning of any unlisted nomenclature may be ascertained from that given.

- A \equiv equivalent area of reinforcing steel; total required steel per foot of width
- A_g \equiv gross area of column
- A_s \equiv area of reinforcing steel
- a \equiv ratio used to obtain properties of non-prismatic members
- Bl \equiv identification for first basic set of loads, those with the conduit empty
- b \equiv width of reinforced concrete member; ratio used to obtain properties of unsymmetrical non-prismatic members
- b_c \equiv outside width of conduit
- C \equiv carry-over factor; a parameter in the equation for equivalent axial load; a coefficient in the expression for allowable flexural bond stress
- C_b \equiv carry-over factor for bottom slab
- C_{JK} \equiv carry-over factor from end J to end K
- C_p \equiv load coefficient for positive projecting conduits
- C_s \equiv carry-over factor for sidewall
- C_t \equiv carry-over factor for top slab
- D \equiv nominal diameter of reinforcing bar; a parameter in the equation for equivalent axial load
- d \equiv effective depth of reinforced concrete member
- d'' $= d - t/2$
- d_{bal} \equiv effective depth for balanced working stresses
- d_{sb} \equiv effective depth of sidewall at bottom face
- d_{st} \equiv effective depth of sidewall at top face or at d_{st} from top face
- d_{wb} \equiv unit dead weight carried by bottom slab
- d_{wt} \equiv unit dead weight of top slab
- E \equiv modulus of elasticity
- e \equiv eccentricity of direct force measured from center of section
- F \equiv coefficient in the cubic equation used to locate the neutral axis
- f_c \equiv compressive stress in concrete
- f_c' \equiv compressive strength of concrete
- f_s \equiv stress in reinforcing steel
- G \equiv a parameter in the equation for equivalent axial load
- H_c \equiv vertical distance from top of conduit to top of embankment

- H_m \equiv vertical distance from phreatic surface to top of embankment
 H_w \equiv vertical distance from top of conduit to phreatic surface
 h_c \equiv clear height of conduit
 h_w \equiv internal water pressure head measured from the bottom of the top slab
 I \equiv moment of inertia
 j \equiv ratio used in reinforced concrete relations
 K_o \equiv coefficient of lateral pressures at rest
 k \equiv ratio used in reinforced concrete relations; stiffness coefficient
 L \equiv span length
 L' \equiv clear span
 $LC\#1$ \equiv load combination number one
 L_b \equiv bottom slab span
 L_p \equiv span between points of inflection
 L_s \equiv sidewall span
 L_t \equiv top slab span
 M \equiv moment
 M_A \equiv design moment at A
 M_{ab} \equiv a moment in ES-28
 M_B \equiv design moment at top corner diagonal
 M_{Bi} \equiv external load corner moment at B for LC#1
 M_{Bs} \equiv design moment at face of the top support of the sidewall
 M_{Bt} \equiv design moment at face of the support of the top slab
 M_{Bub} \equiv corner moment at B for unit load on bottom slab
 M_{Bus} \equiv corner moment at B for unit load on sidewalls
 M_{But} \equiv corner moment at B for unit load on top slab
 M_{Bhd} \equiv corner moment at B for pressure head loading
 M_{Bhy} \equiv corner moment at B for hydrostatic sidewall loading
 M_{JK} \equiv moment at J in span JK
 M_{Bhy}^F \equiv fixed end moment at B for hydrostatic sidewall loading
 M_{JK}^F \equiv fixed end moment at J in span JK
 $M_{L'}^F$ \equiv fixed end moment for span L'
 M_s \equiv equivalent moment, moment about axis at the tension steel
 m^F \equiv fixed end moment coefficient
 N \equiv direct force on a section
 N_b \equiv direct force in bottom slab

N_{Bk} \equiv direct force on top corner diagonal
 N_C \equiv direct compressive force
 N_S \equiv direct force in sidewall
 N_t \equiv direct force in top slab; direct tensile force
 n \equiv modular ratio; an integer; number of bars per foot of width
 P \equiv axial column load
 p \equiv unit load
 p_b \equiv unit load on bottom slab
 p_{bi} \equiv unit load on bottom slab for LC#i
 p_g \equiv gross steel ratio
 p_{h1} \equiv horizontal unit load corresponding to LC#1
 p_{hd} \equiv unit load for pressure head loading
 p_{hy} \equiv maximum unit load for hydrostatic sidewall loading
 p_s \equiv unit load on sidewall
 psf \equiv pounds per square foot
 p_{si} \equiv unit load on sidewall for LC#i
 p_t \equiv unit load on top slab; steel ratio for temperature and shrinkage
 R \equiv reaction
 S \equiv stiffness
 S_b \equiv stiffness of bottom slab
 S_{JK} \equiv stiffness at end J in span JK
 S_s \equiv stiffness of sidewall
 S_t \equiv stiffness of top slab
 s \equiv spacing of reinforcing steel
 t \equiv thickness
 t_b \equiv thickness of bottom slab
 t_s \equiv average thickness of sidewall
 t_{sb} \equiv thickness of sidewall at the bottom
 t_{st} \equiv thickness of sidewall at the top
 t_t \equiv thickness of top slab
 u \equiv allowable flexural bond stress in concrete
 V \equiv shear
 V_b \equiv shear at bottom face of sidewall
 V_{Bt} \equiv shear at face of support of top slab
 V_{ex} \equiv extra shear in sidewall due to loading on top slab
 V_f \equiv shear at top face of sidewall
 V_p \equiv shear at section of maximum positive moment; shear at point of inflection

- V_t \equiv shear at top face of sidewall
- v \equiv allowable shear stress in concrete
- W_s \equiv total load on sidewall
- w_c \equiv clear width of conduit
- x_p \equiv distance from center of top support of sidewall to section of maximum positive moment
- z \equiv eccentricity of direct force measured from the tension steel
- γ_b \equiv buoyant unit weight of embankment
- γ_m \equiv moist unit weight of embankment
- γ_s \equiv saturated unit weight of embankment
- γ_w \equiv unit weight of water
- θ_J \equiv rotation at support J
- ρ \equiv projection ratio for positive projecting conduits

TECHNICAL RELEASE
NUMBER 42

SINGLE CELL RECTANGULAR CONDUITS
CRITERIA AND PROCEDURES FOR STRUCTURAL DESIGN

Computer Designs

The Soil Conservation Service annually designs a number of cast-in-place rectangular conduits for use in principal and emergency spillways passing through earth embankments. Thorough design of these rectangular conduit cross sections by manual methods is a time consuming process. Because of the statical indeterminacy, the interaction of member thicknesses with moments makes direct design difficult. After an adequate set of member thicknesses is obtained, steel requirements must be completely determined.

A computer program written in FORTRAN for IBM 360 equipment was developed to perform this design task. The program executes the complete structural design of single cell rectangular conduit cross sections given the clear height and width of the conduit, two load combinations, and the design mode. The program was used in the preparation of Technical Release No. 43 "Single Cell Rectangular Conduits - Catalog of Standard Designs."

This technical release documents the criteria and procedures used in the computer program. The technical release may be useful as a reference and as a training tool for similar structural problems.

Section Designed

Figure 1 defines the cross sectional shape of the conduit and shows the assumed steel layout. No attempt is made herein to completely identify the computer output listing nor all of the associated nomenclature. This is done in Technical Release No. 43.

The computer program determines the required thicknesses of the top and bottom slabs and the thicknesses at the top and bottom of the sidewalls. Then the computer obtains the minimum acceptable steel areas and maximum acceptable steel spacings at each of the fourteen locations shown in Figure 1. In the case of positive center steel, the spacings actually computed are those required at the respective points of inflection. The computer also determines whether or not any of the positive steel requires definite anchorage at the corners of the conduit.

Loads Specified by User

The design of rectangular conduit sections by the program is independent of the methods by which the user determines his external loads. The user specifies, or selects, unit pressures in two combinations of external loads. These load combinations are defined as:

IC#1 is the load combination having the maximum possible vertical unit load combined with the minimum horizontal unit load consistent with that vertical unit load.

LC#2 is the load combination having the maximum possible horizontal unit load combined with the minimum vertical unit load consistent with that horizontal unit load.

The computer design is adequate for these two load combinations as well as a number of others constructed from them. See page 5 for a more general discussion of loads and load combinations for rectangular conduits.

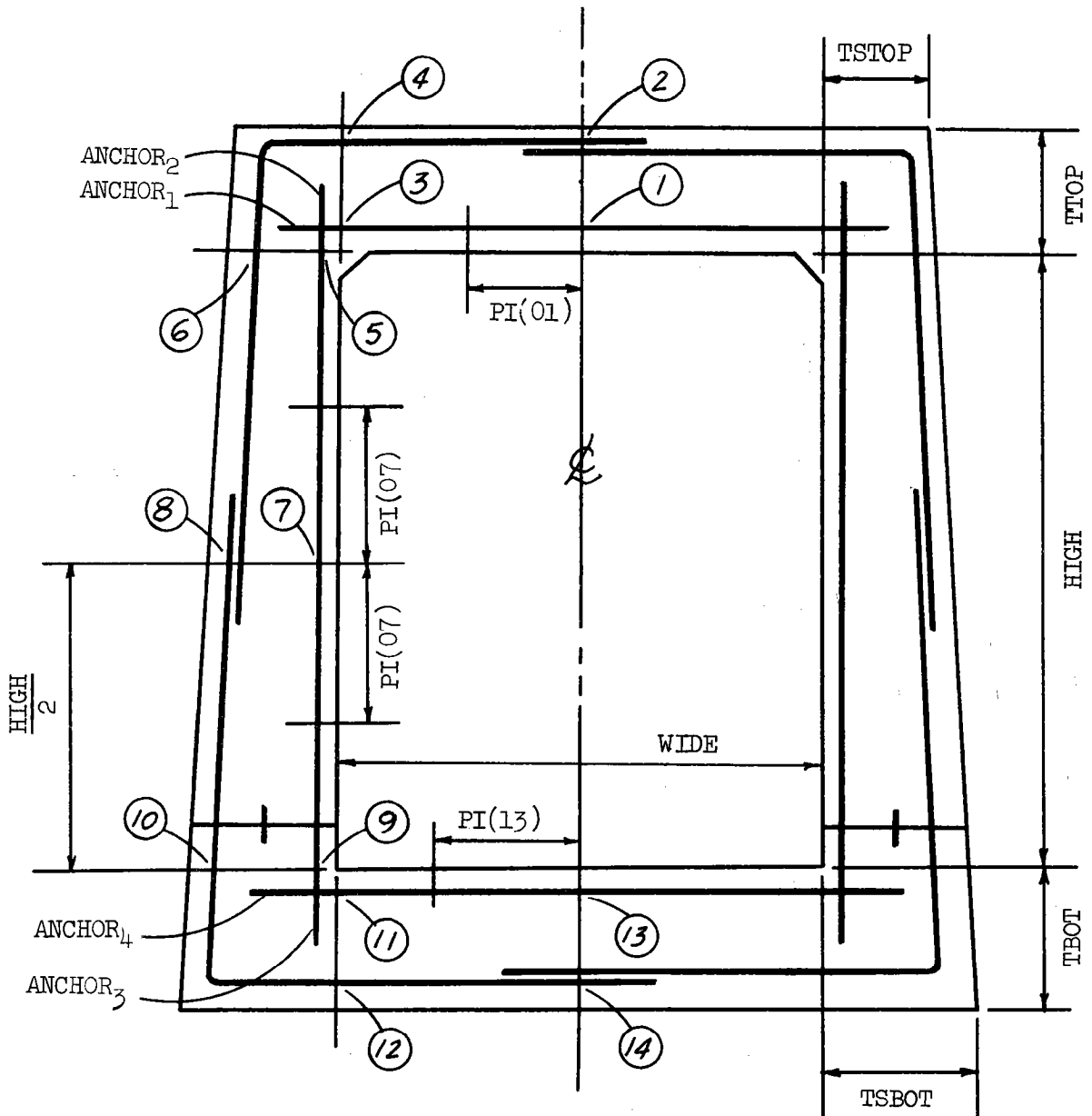

Figure 1. Conduit cross section and steel layout.

Design Mode

The program designs conduit sections in accordance with the design mode. A design mode characterizes the conditions for which the conduit is designed. Four modes are established:

earth foundation, no internal water load ≡ 00
earth foundation, with internal water load ≡ 01
rock foundation, no internal water load ≡ 10
rock foundation, with internal water load ≡ 11

The type of foundation assumed in the design governs the number of external load combinations that are considered. Internal water loads are included in the design of pressure conduits. Note that these conduits flow full only intermittantly. This represents a more severe case than either a conduit that never contains internal water or a conduit that always contains internal water at design pressure.

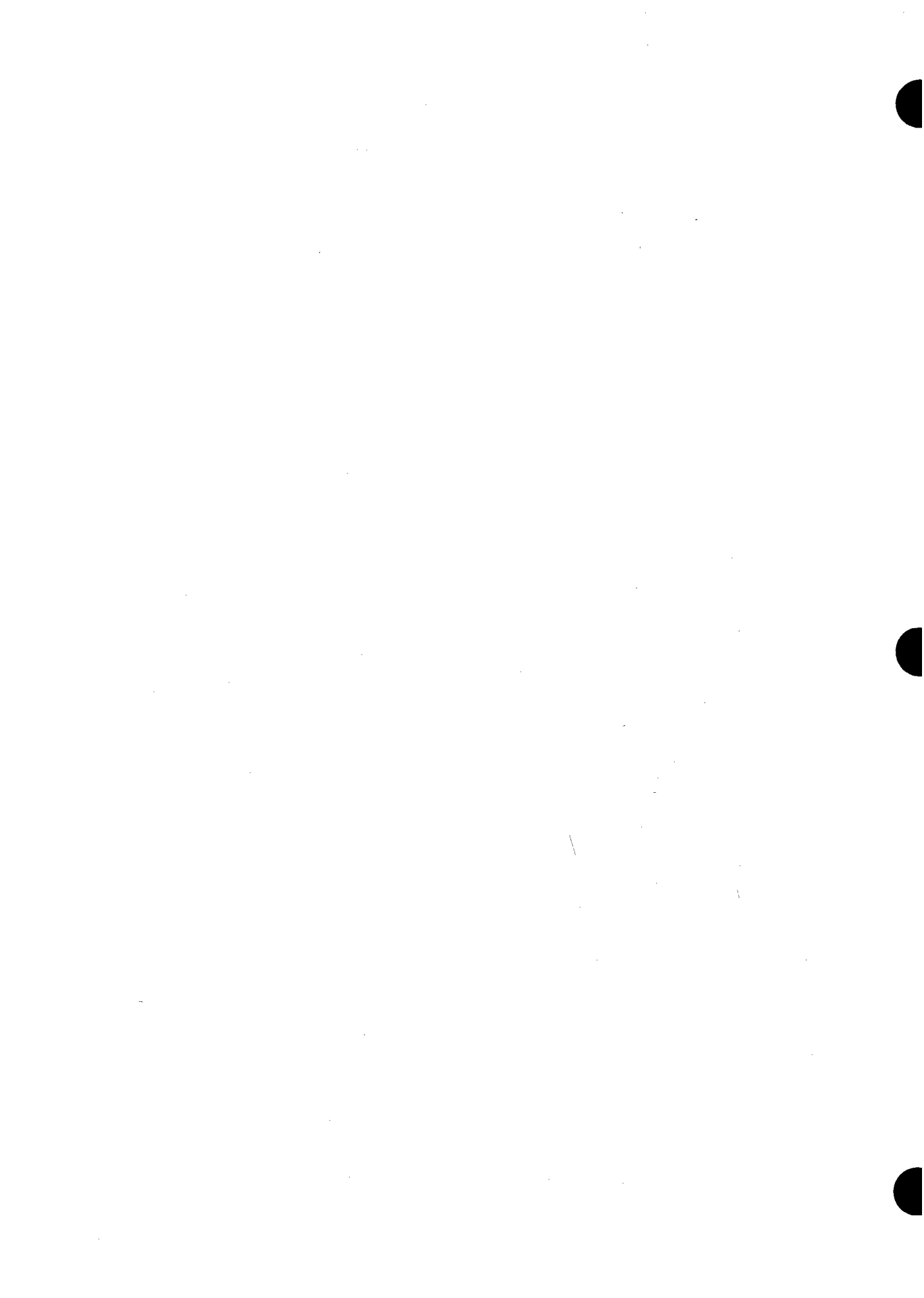

Loads on Rectangular Conduits

Loads on conduits are of two types - external loads and internal loads. For the purposes of this technical release, external loads are due to embankment material and contained water plus any surcharge water above the embankment surface and also include the dead weight effects of the conduit, internal loads are due to water within the conduit. The conduit must be designed to satisfactorily resist a number of possible loading conditions which may occur over the life of the structure.

External Loads

Loads are assumed uniformly distributed on the top slab, sidewalls, and bottom slab except for the bottom slab of conduits founded on rock. Appropriate recognition is made of the fact that actual side-wall loads are trapezoidal and may vary from nearly triangular to nearly uniform distributions.

Conduits on earth foundations. - Load combinations producing the maximum requirements for concrete thicknesses, steel areas, and bond should be used in design. Qualitative influence lines may be employed to help ascertain these critical load combinations. The ordinates of an influence line give the value of some function at a specific location caused by a unit load anywhere on the structure. Thus an influence line may (a) suggest theoretical loading patterns, (b) verify the inclusion of various load combinations, and (c) indicate the load combination producing the maximum value of a function.

The three influence lines for M_A , M_B , and M_C in Appendix A (see Figure 9 for location of sections A, B, and C) show that three load combinations must be considered in the design of rectangular conduits on earth. These three load combinations are designated as LC#1, LC#2, and LC#3. They are shown in Figure 2. LC#1 and LC#2 have been defined on pages 1 and 2. If p_{V1} , p_{H1} , p_{V2} , and p_{H2} are the vertical and horizontal external unit loads exclusive of conduit dead weight effects, then by those definitions

$$p_{V1} \geq p_{V2} \text{ and } p_{H2} \geq p_{H1}$$

LC#3 has simultaneously high vertical and lateral pressures. This load combination is not usually of concern in the design of circular or other curved conduits but it should be considered for rectangular conduits since it causes large negative corner moments. For this work, LC#3 is taken as

$$p_{V3} = p_{V1} \text{ and } p_{H3} = p_{H2}$$

Appendix B indicates one situation in which four load combinations may exist at various times. In this situation, LC#1 would correspond to developed condition - moist, while LC#2 would correspond to initial condition - saturated.

Conduits on rock foundations. - Many suggestions are made concerning the distribution of loads on the bottom slabs of conduits founded on rock. One of the common proposals is that the load should be assumed to vary linearly from zero at midspan to a maximum value at the supports. The limit of this approach is to assume the bottom load is concentrated at the sidewalls and the bottom slab itself is not loaded. Although this assumption may sound severe, it actually is not much more so than the assumption of linearity since moments in a span are largely produced by that part of the load near the central portion of the span. Thus three additional load combinations exist, they are designated LC#4, LC#5, and LC#6 and are shown in Figure 2. The latter three load combinations are the same as the former three except that they have no vertical pressure on the bottom slab.

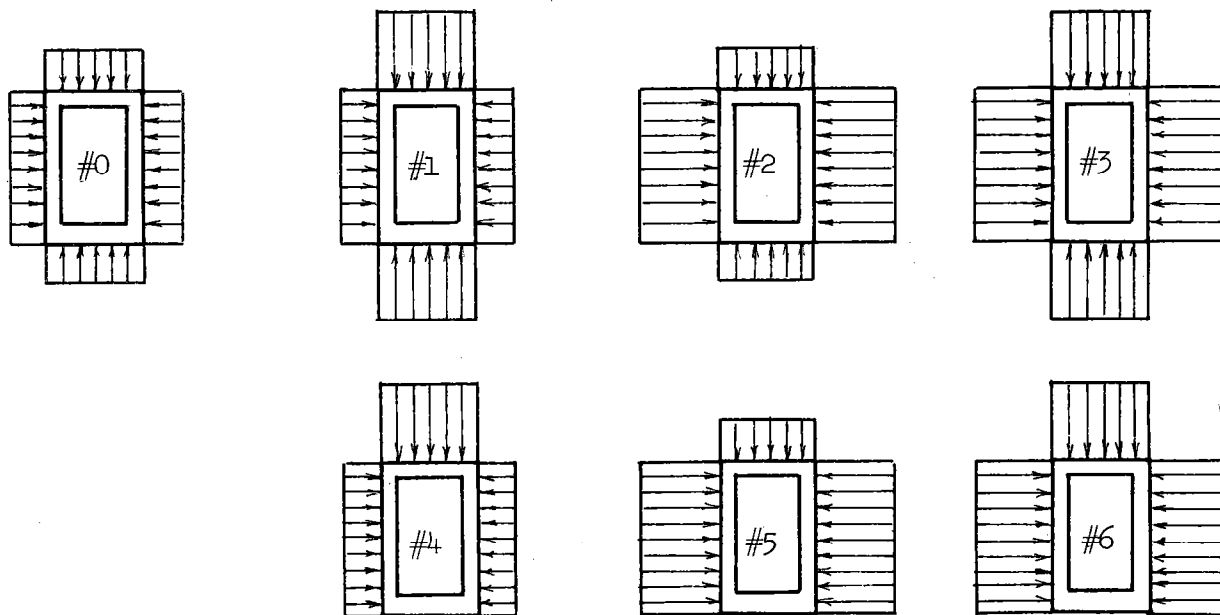

Figure 2. Load combinations producing maximum values at critical locations.

When conduits are founded on rock, the conduits must be able to safely resist all six load combinations since the actual contact and interaction with the rock is unknown. When conduits have large clear spans and are founded on rock, it may be more economical to use a fixed ended frame rather than the closed rectangular shape.

Internal Water Loads

Internal water loads should be considered in the design of rectangular pressure conduits. Although internal water loads will seldom drastically affect the design, they will always in pressure conduits cause either an increase in concrete thickness, or an increase in the theoretical amount of tension steel required at some section, or both. Internal water load may be handled conveniently by treating it as two distinct loadings

- (1) Water to top of conduit, filling the conduit, but not under pressure, and
- (2) Loading due to pressure head, h_w , above the bottom of the top slab.

The first loading amounts to hydrostatic loading on the sidewalls only since load and reaction on the bottom slab cancel each other.

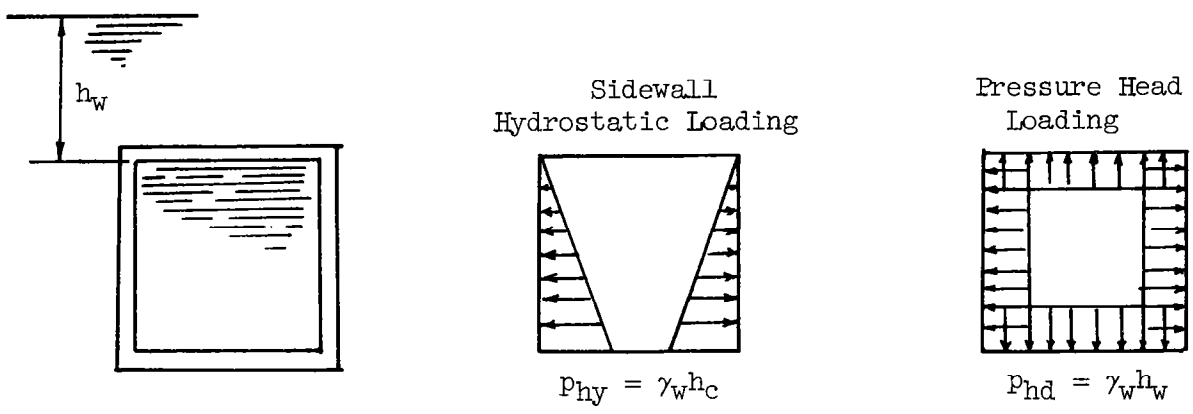

Figure 3. Treatment of internal water loads.

The second loading creates a uniform distribution all around. The magnitude of h_w may be related in some way to the height of embankment over the conduit, it is taken therefore as a function of p_{v2} , or

$$h_w = \frac{1}{2} \left(\frac{p_{v2}}{100} \right)$$

where p_{v2} is in psf and h_w is in ft.

Sketches of the deflected shape of the conduit caused by the hydrostatic loading show that moments at the midspans are positive (tension on the inside of the conduit) for the top and bottom slabs and are negative (tension on outside of the conduit) for the sidewalls. However, deflected shapes caused by the pressure head loading show that midspan moments in any span may take on either sign depending on the proportions of the conduit. It is apparent that moments due to internal water loads are additive to some of the moments of interest due to the external loads.

Basic Sets of Loads

Hence, when a conduit is to carry internal water, there are three basic sets of loads which should be considered to determine the critical combination of loads for each function investigated. These basic sets are identified as

- (B1) External loads only, conduit empty
- (B2) External loads plus internal water loads when conduit is flowing full as an open channel, and
- (B3) External loads plus internal water loads when conduit is flowing full under pressure head, h_w .

Therefore, the problem is to determine which external load combination should be combined with which internal load, if any, to produce the maximum effect for each function. The internal loading is either the sidewall hydrostatic loading or the sidewall hydrostatic loading plus the pressure head loading.

LC#0, shown in Figure 2, is included to take care of those cases for which it is desirable to consider minimum external loads in combination with internal water loads. For this work, LC#0 is taken as

$$p_{v0} = p_{v2} \text{ and } p_{h0} = p_{h1}$$

Method of Analysis for Indeterminate Moments

General Considerations

Slope Deflection is selected as the method of analysis for use in this work because the method yields explicit solutions. Although Moment Distribution in some instances yields exact solutions, in general it is a method of successive approximations which is summed after some finite number of cycles of distribution are performed. Hence, where a large number of solutions are required, an explicit method of analysis has an advantage over a method requiring iterative procedures.

In accordance with usual theory, the analysis assumes straight-line stress distribution on a cross section. This assumption is less well satisfied as the thickness-to-span ratio increases. For thick members, the effect of shearing strains is important.

Members are assumed non-prismatic having a constant moment of inertia within the clear span and having moments of inertia which approach infinity outside the clear span. This assumption, when used with the side-walls, introduces approximations discussed below. Figure 4 shows this variation in moments of inertia.

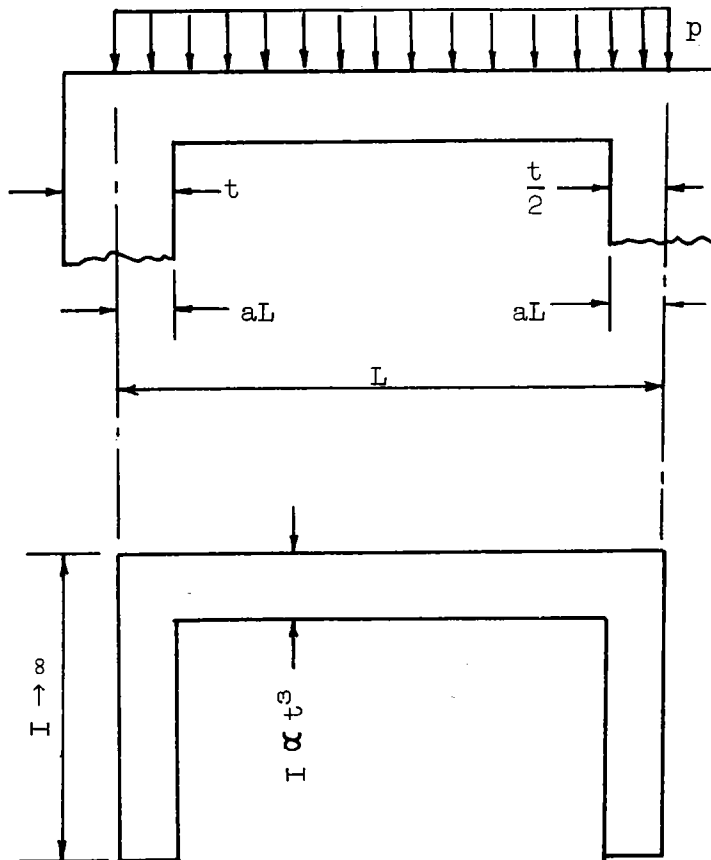

Figure 4. Assumed variation in moment of inertia.

Dissymmetry of Sidewalls

See Figure 5 which identifies the nomenclature concerning spans and member thicknesses. The conduit lacks symmetry of shape about any horizontal axis because of two inequalities. These are

$$t_b > t_t$$

$$t_{sb} > t_{st}$$

Both inequalities cause the sidewalls to lack symmetry and therefore cause the sidewall stiffnesses, carry over factors and fixed end moments to be different at the top and bottom of the sidewalls. Final moments and shears are affected to some extent. Two questions arise; first, how serious is the effect and second, how should the sidewall be treated?

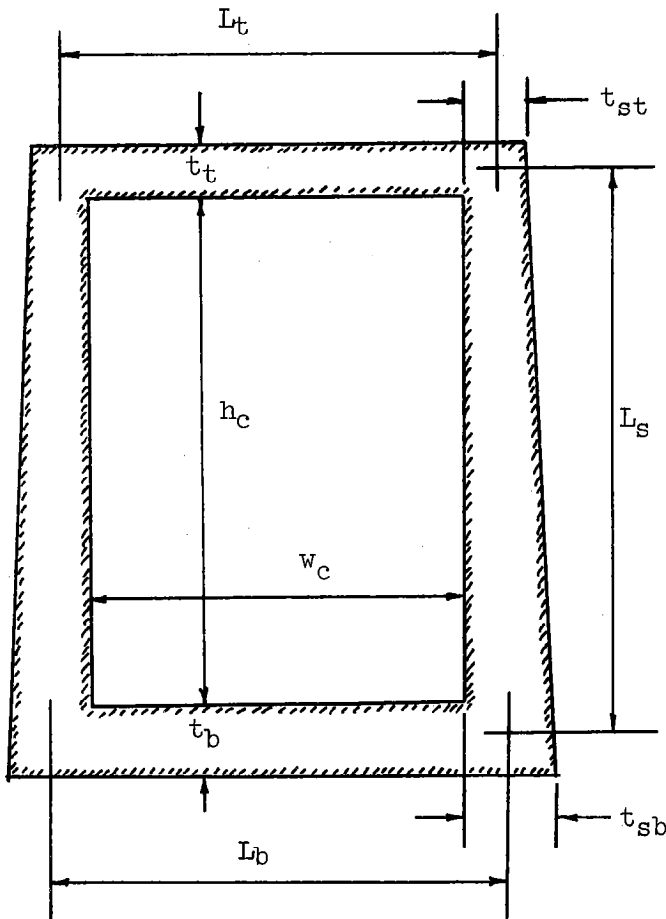

Figure 5. Conduit spans and member thicknesses.

Some insight into the effect of this lack of symmetry of shape on the final moments may be obtained by considering the effect of varying the stiffnesses of either the tops of the sidewalls or the bottoms of the sidewalls. Note that both inequalities produce the same sort of result since both represent, as compared to equality situations, a decrease in stiffness of the tops and an increase in stiffness of the bottoms of the sidewalls.

Consideration that $t_b \geq (t_t + 1)$. - The bottom slab thickness will exceed the top slab thickness because the bottom slab carries a slightly larger dead load than the top slab and the bottom slab has 1 inch more concrete cover over the outside steel than does the top slab. The

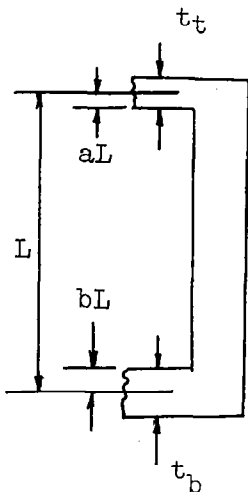

Figure 6. Unequal slab thicknesses.

importance of this inequality may be evaluated qualitatively by observing Figures 29-31 on pages 152-154 in "Continuous Frames of Reinforced Concrete" by Cross and Morgan where $aL = \frac{1}{2}(t_t)$, $bL = \frac{1}{2}(t_b)$, and $L = h_c + \frac{1}{2}(t_t + t_b)$. These charts can be used to obtain stiffnesses and carry over factors for various a and b values. Values of fixed end moments can be computed by statics knowing $M_L^F = \frac{1}{12}p(L')^2$ where $L' = L - aL - bL$.

Note that t_b will not differ from t_t by more than a few inches at most. It seems clear that the effect of this inequality can not be great within the existing limits of relative values of t_b and t_t . Thus it is concluded, it is not necessary to make the refinement that $t_b \neq t_t$. To obtain values for design use

$$aL = bL = \frac{1}{4}(t_t + t_b).$$

Consideration that $t_{sb} > t_{st}$. - The thickness of the sidewall increases in a downward direction because of the necessity of providing batter on the outside surfaces of the walls. The

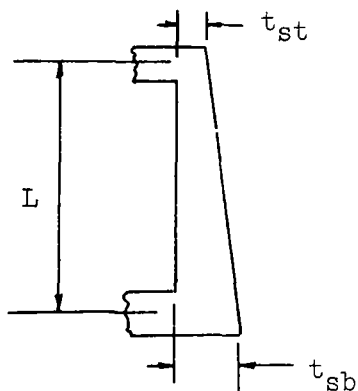

Figure 7. Sidewall batter.

importance of this inequality may be evaluated qualitatively by observing Figure 27 on page 150 of Cross and Morgan or by observing Charts 2 and 3 on pages 258 and 259 in "Statically Indeterminate Structures" by Anderson. The source of these charts is noted as the Portland Cement Association, they can be found in several texts. The parameters of interest can be obtained from the right hand sides of the pairs of Graphs 1, 2, and 3. Note that t_{sb} and t_{st} are not greatly different within the clear height of the sidewall since the batter is about $3/8$ inch per foot. Thus it is concluded, it is not necessary to make the refinement that $t_{sb} \neq t_{st}$. To obtain values for design assume the thickness of the sidewall is constant and use

$$t_s = \frac{1}{2}(t_{st} + t_{sb})$$

Slope Deflection Equation

The Slope Deflection Equation used in this analysis is derived for the assumption that members are symmetrical about their centerlines and are subjected to applied loads and end rotations only. That is, members do not undergo relative translation of their ends. The usual Slope Deflection sign convention is followed; clockwise rotations are positive, clockwise joint moments are positive.

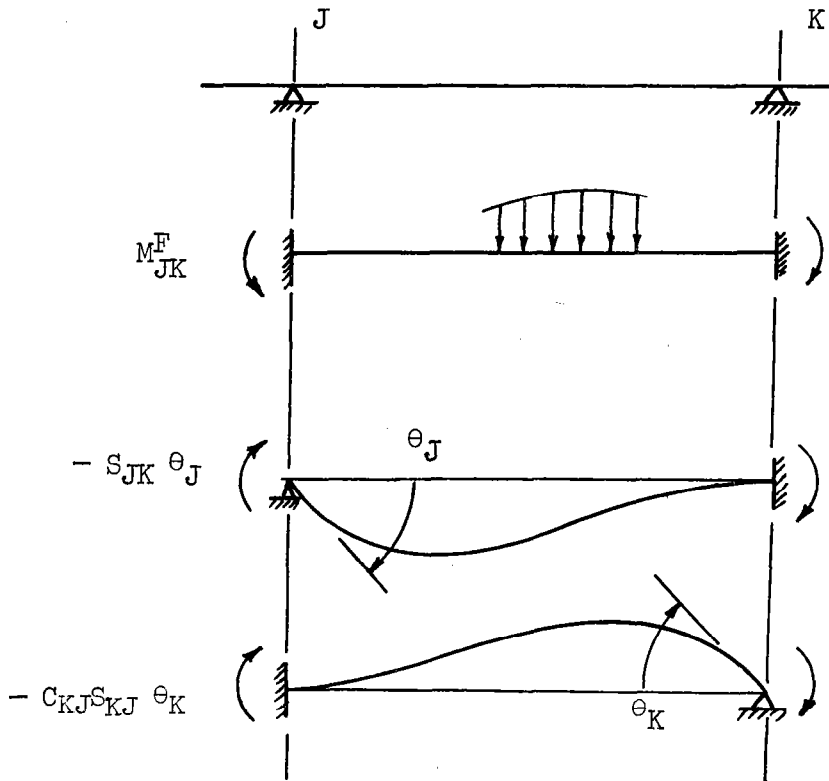

Figure 8. Development of Slope Deflection Equation.

From Figure 8

$$M_{JK} = M_{JK}^F - S_{JK} \theta_J - C_{KJ} S_{KJ} \theta_K$$

and similarly

$$M_{KJ} = M_{KJ}^F - S_{KJ} \theta_K - C_{JK} S_{JK} \theta_J$$

however, due to symmetry

$$S_{JK} = S_{KJ} = S \text{ and } C_{JK} = C_{KJ} = C$$

then

$$M_{JK} = M_{JK}^F - S(\theta_J + C\theta_K)$$

$$M_{KJ} = M_{KJ}^F - S(\theta_K + C\theta_J)$$

where

M_{JK} is the moment at J in span JK

M_{KJ} is the moment at K in span JK

M_{JK}^F is the fixed end moment at J in span JK

M_{KJ}^F is the fixed end moment at K in span JK

S_{JK} is the stiffness at end J in span JK

S_{KJ} is the stiffness at end K in span JK

C_{JK} is the carry over factor from end J to end K

C_{KJ} is the carry over factor from end K to end J

θ_J is the end rotation at support J

θ_K is the end rotation at support K

Slope Deflection Method

Both the loading on, and the shape of, these single cell rectangular conduits are symmetrical about the vertical centerline of the structure. Hence no joint can translate. There are two unknown displacements, say

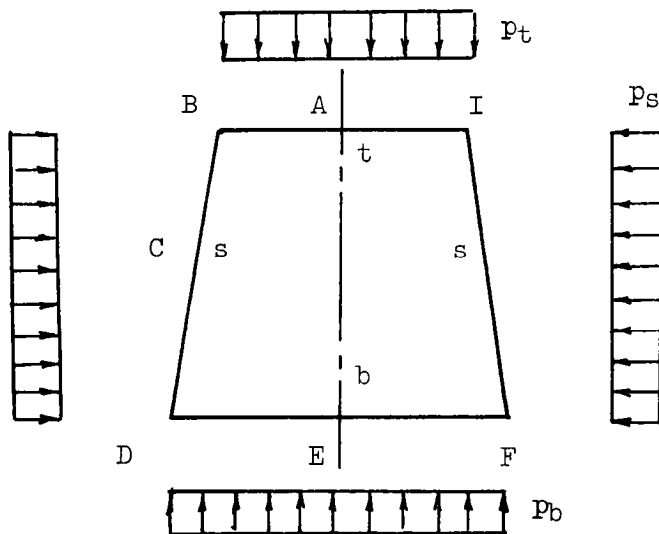

Figure 9. Designations for analyses.

the two rotations θ_B and θ_D since by symmetry $\theta_I = -\theta_B$ and $\theta_F = -\theta_D$. Two joint (statical moment) equations are required to determine these rotations. Say

$$\Sigma M_B = M_{BI} + M_{BD} = 0$$

$$\Sigma M_D = M_{DB} + M_{DF} = 0$$

By the Slope Deflection Equations:

$$M_{BI} = M_{BI}^F - S_t(1 - C_t)\theta_B$$

$$M_{BD} = M_{BD}^F - S_s(\theta_B + C_s\theta_D)$$

and

$$M_{DB} = M_{DB}^F - S_s(\theta_D + C_s\theta_B)$$

$$M_{DF} = M_{DF}^F - S_b(1 - C_b)\theta_D$$

These expressions for moment may be substituted in the joint equations from which θ_B and θ_D may be determined. The values of θ_B and θ_D can then be inserted in the Slope Deflection Equations yielding for the general case assumed herein:

$$M_{BI} = M_{BI}^F - S_t(1 - C_t) \left[\frac{\{(1 - C_b)S_b + S_s\} (M_{BI}^F + M_{BD}^F) - C_s S_s (M_{DB}^F + M_{DF}^F)}{\{(1 - C_t)S_t + S_s\} \{(1 - C_b)S_b + S_s\} - (C_s S_s)^2} \right]$$

and

$$M_{DF} = M_{DF}^F - S_b(1 - C_b) \left[\frac{\{(1 - C_t)S_t + S_s\} (M_{DB}^F + M_{DF}^F) - C_s S_s (M_{BI}^F + M_{BD}^F)}{\{(1 - C_t)S_t + S_s\} \{(1 - C_b)S_b + S_s\} - (C_s S_s)^2} \right]$$

also

$$M_{BD} = -M_{BI}$$

$$M_{DF} = -M_{DB}$$

The various fixed end moments, stiffnesses, and carry over factors involved may be computed from the relations

$$\text{Fixed end moment} = M_i^F = m_i^F p_i L_i^2$$

$$\text{Stiffness} = S_i = k_i EI_i/L_i \propto k_i t_i^3/L_i$$

$$\text{Carry over factor} = C_i$$

The coefficients m_i , k_i , and C_i may be obtained from Table 2-5, page 2-9 of Technical Release No. 30, or from the expressions

$$m_i^F = \frac{1}{12}(1 + 2a - 2a^2)$$

$$k_i = \frac{1}{(1 - 2a) \left\{ 1 - \frac{3}{4(1 - a + a^2)} \right\}}$$

$$C_i = \frac{3}{2(1 - a + a^2)} - 1$$

where (a) is defined in Figure 4 .

In the analysis, take for top slab, sidewall, and bottom slab respectively

$$\begin{array}{lll}
 L_t = w_c + t_{st} & a_t L_t = \frac{1}{2} t_{st} & t_t = t_t \\
 L_s = h_c + \frac{1}{2}(t_t + t_b) & a_s L_s = \frac{1}{4}(t_t + t_b) & t_s = \frac{1}{2}(t_{st} + t_{sb}) \\
 L_b = w_c + t_{sb} & a_b L_b = \frac{1}{2} t_{sb} & t_b = t_b
 \end{array}$$

The resultant expressions for M_{BI} and M_{DF} may be checked against known solutions for special cases, for instance M_K in Tables 2-4 and 2-6 of Technical Release No. 30, also M_{ab} and M_{dc} in ES-28.

Design Criteria

Materials

Class 4000 concrete and intermediate grade steel are assumed.

Working Stress Design

Design of sections is in accordance with working stress methods. The allowable stresses in psi are

Extreme fiber stress in flexure	$f_c = 1600$
Shear, V/bd at (d) from face of support *	$v = 70$
Flexural Bond	
tension top bars	$u = 3.4\sqrt{f_c'}/D$
other tension bars	$u = 4.8\sqrt{f_c'}/D$
Steel	
in tension	$f_s = 20,000$
in compression, axially loaded columns	$f_s = 16,000$

Minimum Slab Thicknesses

Top slab and sidewalls	10 inches
Bottom slab	11 inches

Sidewall Batter

Approximately $3/8$ in. per foot, using whole inches for sidewall thicknesses at top and bottom of the sidewall.

Temperature and Shrinkage Steel

The minimum steel ratios are

for outside faces	$p_t = 0.001$
for inside faces	$p_t = 0.002$

Slabs more than 32 inches thick are taken as 32 inches.

Web Reinforcement

The necessity of providing some type of stirrup or tie in the slabs because of bending action is avoided by

- (1) limiting the shear stress, as a measure of diagonal tension, so that web steel is not required, and
- (2) providing sufficient effective depth of sections so that compression steel is not required for bending.

Cover for Reinforcement

Steel cover is everywhere 2 inches except for outside steel in the bottom slab where cover is 3 inches.

Spacing of Reinforcement

The maximum permissible spacing of any reinforcement is 18 inches.

*In some cases shear may be critical at the face of the support, see page 17.

Slab Thicknesses Required by Shear

Consideration of various influence lines for shear at the faces of supports indicate that with the exception of shear in the sidewalls of conduits on rock, shear thickness design of a particular slab may be performed assuming the slab is a simple span. This is obviously true of top and bottom slabs due to symmetry of load and shape of the structure about the vertical centerline of the structure. It is an approximation when applied to sidewall design since the corner moments at top and bottom are in general unequal. The moments are unequal because neither the loads nor the shape of the structure is symmetrical about any horizontal line.

Location of Critical Sections for Shear

In ordinary beams and slabs the shear within distance (d) from the face of a support is less critical than that at the distance (d) from the support. The ACI Code therefore stipulates critical shear as that located a distance (d) from the support. However, with reaction conditions as illustrated in sketch (b) of Figure 10, diagonal tension cracking can take place at the face of the support. Computation of critical shear at distance (d) does not apply in such cases, critical shear is located at the face of the support.

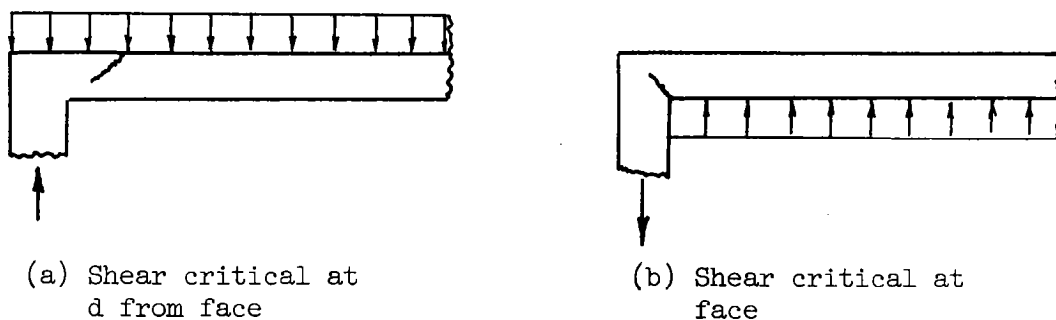

Figure 10. Location of critical shear.

When internal water loads are included in the design of rectangular conduits, required shear thickness is sometimes controlled by shear at the face of the support.

Design of Top Slab

The top slab of a pressure conduit is subject to two possible controlling loads as shown in Figure 11.

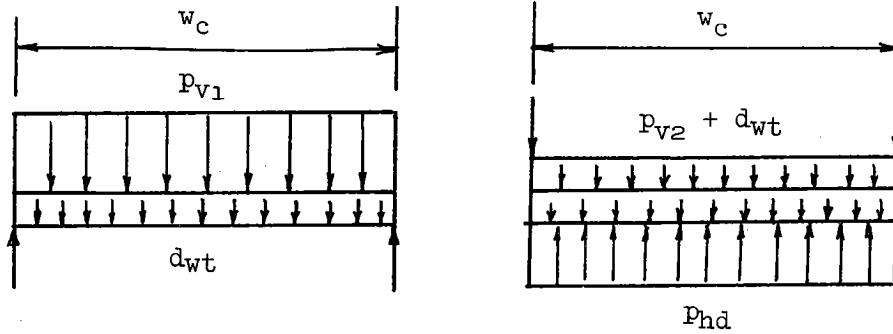

Figure 11. Loads for shear thickness design of top slab.

Shear in the top slab depends on the dead weight of the slab. The dead weight depends on the thickness which is initially unknown. Hence a convergence procedure is desirable. The larger of the two computed thicknesses controls.

$$t_t = d + 2.5$$

$$d_{wt} = 150t_t/12$$

from the first loading, shear critical at distance (d)

$$v = \frac{\frac{1}{2}(p_{v1} + d_{wt})w_c - (p_{v1} + d_{wt})d/12}{bd}$$

or

$$t_t = \frac{\frac{1}{2}(p_{v1} + d_{wt})w_c}{840 + (p_{v1} + d_{wt})/12} + 2.5$$

from the second loading, shear critical at face

$$t_t = \frac{\frac{1}{2}(p_{hd} - p_{v2} - d_{wt})w_c}{840} + 2.5$$

If $(p_{hd} - p_{v2} - d_{wt}) < 0$, the second shear does not exist. In these relations

p_{v1} = vertical unit load of LC#1, in psf

p_{v2} = vertical unit load of LC#2, in psf

$p_{hd} = \gamma_w h_w = 62.4 h_w$, in psf

d_{wt} = dead weight of top slab, in psf

w_c = clear width of conduit, in ft.

b = 12 inches

d = effective depth, in inches

t_t = thickness of top slab, in inches

v = allowable shear stress = 70 psi

Design of Sidewall

The sidewall design for required shear thickness is more complex than that of the top slab. Several problems need consideration, among these are

- (1) sidewall loads are trapezoidal,
- (2) sidewall thickness increases with depth,
- (3) critical sidewall shear for conduits on rock is usually a function of the maximum external loads on the top slab, and
- (4) internal water loads for pressure conduits may produce critical sidewall shear at either the face of the top support or the face of the bottom support.

Conduits founded on earth, without internal water loads. - This case is the simplest to design. As previously noted, the actual external lateral loads are trapezoidal ranging from nearly triangular for conduits near the surface to nearly uniform for conduits at great depth. What is needed is some way of conservatively approximating the shear diagram over those portions of it that may be critical.

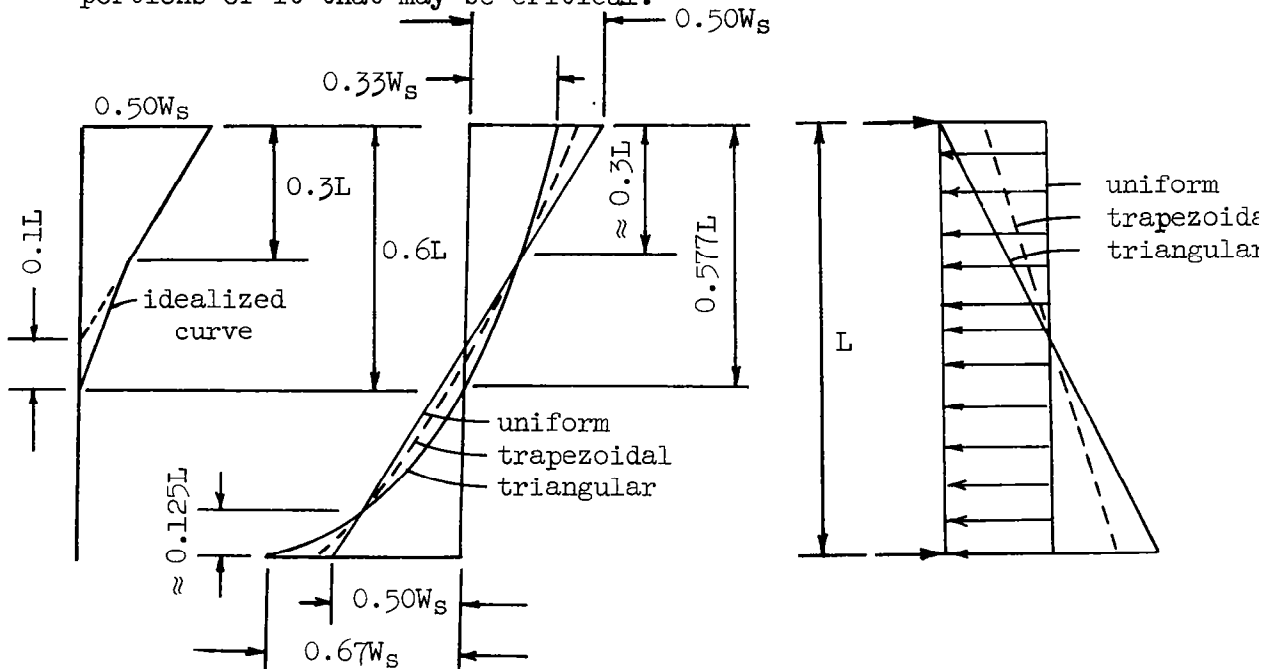

Figure 12. Load distributions and shear diagrams for same total lateral load, W_s .

Figure 12 shows that the assumption of a uniform load gives conservative shear values between $0.0L$ and $0.3L$ from the top and between $0.125L$ and $0.5L$ from the bottom. Usually conservative shear values between $0.3L$ and $0.6L$ from the top may be obtained by using the idealized curve indicated. Recalling that shear stress is critical at (d) from the face of a support, then shear between $0.0L$ and $0.125L$ from the bottom will never be critical for all but perhaps those conduits having very large clear heights and small loads. Further, since sidewall thicknesses over the lower half of the sidewall are greater than over the upper half, sidewall thickness will not be controlled by shear between $0.125L$ and $0.5L$ from the bottom.

The following procedure for determining the sidewall thickness for the conduits therefore applies. Compute the required effective depth on the assumption of a uniformly loaded simple span loaded with p_{h2} . If the critical section at (d) from the face of the top support, is more than $0.3L$ from the top, recompute the required effective depth on the basis of the idealized curve. With (d) known compute the sidewall thickness at the top, t_{st} , and the sidewall thickness at the bottom, t_{sb} , taking into account the required batter. Equations for these computations are given below in combination with requirements for conduits on rock.

Conduits founded on rock, without internal water loads. - The influence line for shear V_B in the sidewall, given in Appendix A, shows that loads on the top slab produce the same kind of shear at the top of the sidewall as does the sidewall loading, however loads on the bottom slab produce the opposite kind of shear. When conduits are on rock, loads on the top slab are possible when the bottom slab is not loaded. Thus LC#6 produces the maximum shear at the top of the sidewall. This conclusion is verified by Figure 13 which shows the deflected shape and sense of end moments on the sidewall due to loading on the top slab. These end moments produce an extra shear which adds to that due to the sidewall loads.

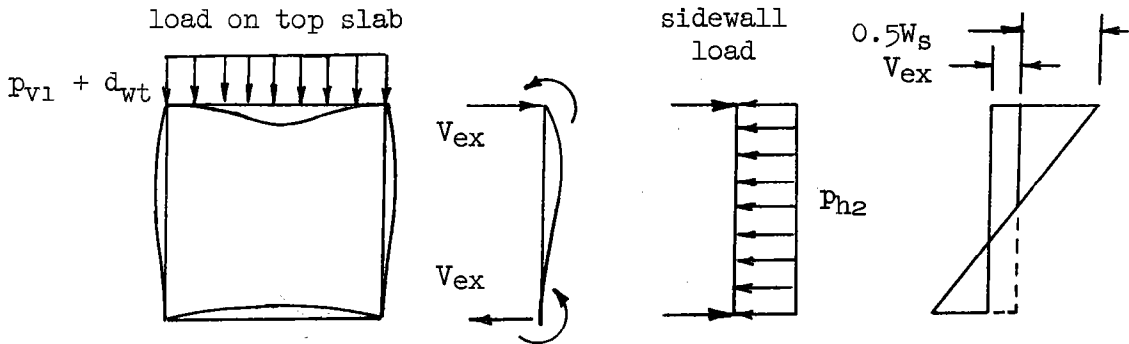

Figure 13. Sidewall shear, conduits on rock foundation.

This extra shear, V_{ex} , can be added to the shear diagram for sidewall loads and the procedures given above for conduits on earth foundations may be followed. Figure 14 shows a portion of this combined shear diagram rotated 90 degrees.

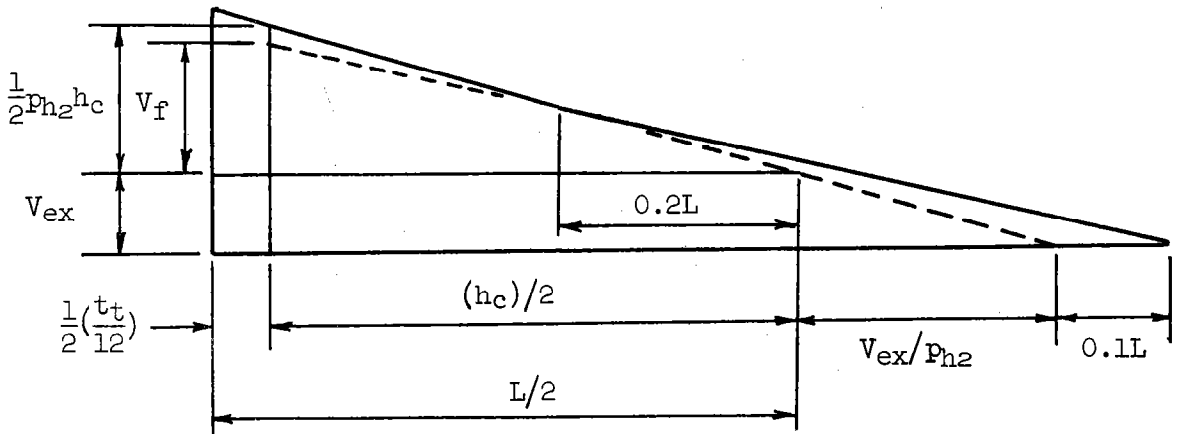

Figure 14. Partial sidewall shear diagram.

Assuming the critical section for shear is not more than $0.3L$ from the top (left end), then

$$v = \frac{\frac{1}{2} p_{h2} h_c + V_{ex} - p_{h2} d_{st}/12}{bd_{st}}$$

or

$$d_{st} = \frac{\frac{1}{2} p_{h2} h_c + V_{ex}}{840 + p_{h2}/12}$$

However, if the critical section is more than $0.3L$ from the top, that is, if

$$\left(\frac{1}{2}t_t + d_{st}\right)/12 > 0.3\left(\frac{t_t}{12} + h_c\right)$$

then get the new shear at the face of the support, which is

$$V_f + V_{ex} = \left\{ \left(\frac{1}{2} p_{h2} h_c \right) \left(\frac{0.2L}{h_c/2} \right) + V_{ex} \right\} \left\{ \frac{\frac{1}{2}h_c + V_{ex}/p_{h2} + 0.1L}{0.3L + V_{ex}/p_{h2}} \right\}$$

divide this by $\left(\frac{1}{2}h_c + V_{ex}/p_{h2} + 0.1L\right)$ to obtain the new effective unit load. The required effective depth becomes

$$d_{st} = \frac{V_f + V_{ex}}{840 + \left(\frac{V_f + V_{ex}}{\frac{1}{2}h_c + V_{ex}/p_{h2} + 0.1L} \right)/12}$$

where V_{ex} = extra shear from top slab load, in lbs

V_f = shear at face from idealized curve, in lbs

L = $h_c + t_t/12$, in ft

h_c = clear height of conduit, in ft

d_{st} = effective depth of sidewall at d_{st} from top, in inches

These expressions may be used for conduits on earth, in which case V_{ex} is equal to zero, or for conduits on rock.

Convergence procedure - conduits on rock. - When conduits are on rock, the correct value for V_{ex} is initially unknown since it depends on the sidewall end moments due to loading on the top slab. These end moments are obtained from indeterminate analyses which are functions of the thicknesses and span lengths of all members, quantities which are in the process of being determined. Thus a convergence approach to design is required here. The initial value of V_{ex} is set at zero. Then the remaining shear design is completed. Indeterminate analyses are performed and the end moments due to top loads obtained. If M_{But} and M_{Dut} , see page 27, are the moments in ft-lbs at B and D due to a uniform load of unity on the top slab, then V_{ex} is given by

$$V_{ex} = (p_{v1} + d_{wt})(M_{But} + M_{Dut}) / \left(h_c + \frac{1}{2}(t_t + t_b) \right) / 12$$

This furnishes a new value for V_{ex} which may be used in the expressions for effective depth, d_{st} . Then the remaining shear design is completed and the cycle is repeated as many times as is necessary. The process is ended when the required sidewall thickness is unchanged from one cycle to the next.

Limit of shear criteria. - A further complication may exist when the sidewall shear includes $V_{ex} > 0$. According to the ACI Code, critical

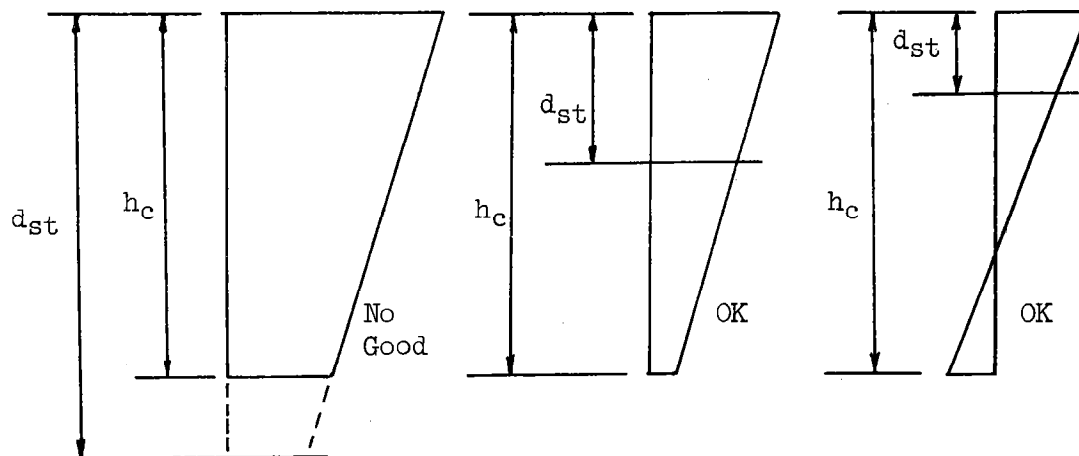

Figure 15. Possible sidewall shear diagrams with V_{ex} included.

sections for shear are located (d) from the face of the support. As indicated in Figure 15 it is possible for the computed value of d_{st} to locate the critical section outside of the span, h_c . If this occurs, the shear criteria is held invalid and the design is terminated.

Conduits with internal water loads. - The sidewall thickness of pressure conduits may be determined by internal water loads rather than by maximum external load combinations. Further it is not known beforehand whether shear at the top or shear at the bottom of the sidewall will control.

At the top, maximum shear due to internal water load occurs, if it exists, when the external loading on the sidewall is a minimum. This can be taken as LC#1. At the bottom, maximum shear due to internal water load occurs, if it exists, when the external loading on the sidewall is a minimum, the external loading on the top slab is a maximum, and the external loading on the bottom slab is a minimum. This is LC#4 for conduits on rock and can be taken as LC#1 for conduits on earth. Note that V_{ex} in this case adds to the shear at the bottom.

For these computations, since p_{h1} is of secondary importance here, it is treated strictly as a uniform load with no adjustment made for a trapezoidal distribution.

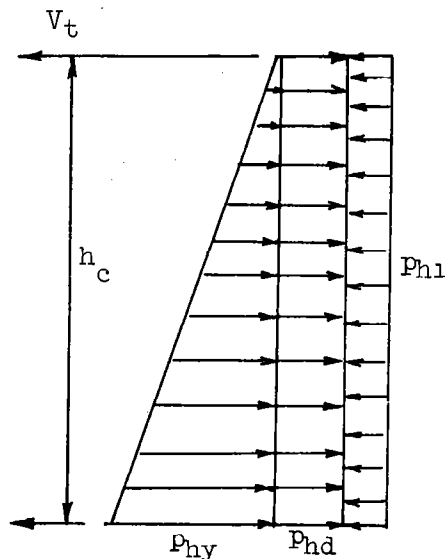

Figure 16. Loading for sidewall thickness, control from top.

so

$$V_t = \frac{1}{2}(P_{hd} - P_{h1})h_c + \frac{1}{3}\left(\frac{1}{2}P_{hy}\right)h_c$$

and the shear stress at the top face is

$$v = V_t/bd_{st}$$

giving

$$d_{st} = V_t/840.$$

where

$$V_t \approx \text{shear at top face, in lbs}$$

$$P_{hy} = \gamma_w h_c = 62.4h_c, \text{ in psf}$$

$$d_{st} = \text{effective depth of sidewall at top face, in inches}$$

If $V_t < 0$ the desired shear does not exist.

The loading diagram when thickness is controlled from the bottom is similar to that when control is from the top except that V_{ex} due to top slab loads must be added as shown in Figure 17.

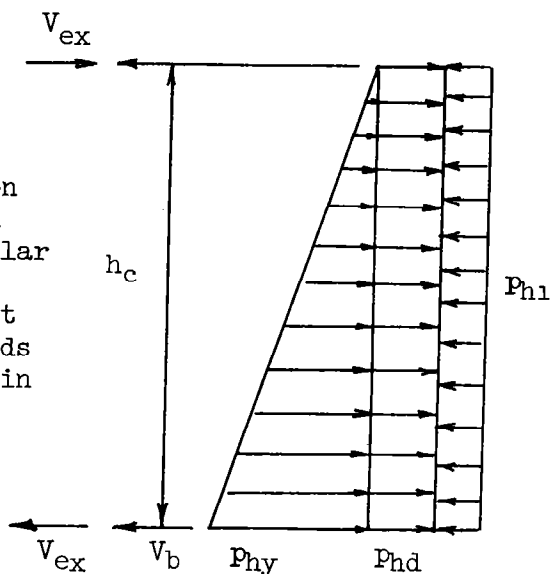

Figure 17. Loading for sidewall thickness, control from bottom.

so

$$V_b = \frac{1}{2}(P_{hd} - P_{hl})h_c + \frac{2}{3}\left(\frac{1}{2} P_{hy}\right)h_c$$

and the shear stress at the bottom face is

$$v = (V_b + V_{ex})/bd_{sb}$$

giving

$$d_{sb} = (V_b + V_{ex})/840.$$

where

$V_b \approx$ shear at bottom face, in lbs

d_{sb} = effective depth of sidewall at bottom face, in inches

If $V_b < 0$ the desired shear can not control.

Summary, shear design of sidewall thickness. - In the general case the thickness of the sidewall may be governed at the top by external loads, at the top with internal water loads, or at the bottom with internal water loads. In the first and last instances extra shear must be added for conduits on rock. The actual thickness required at the top of the sidewall, t_{st} , and the corresponding actual thickness required at the bottom of the sidewall, t_{sb} , is selected from the most critical set of thicknesses determined from the two computed values of d_{st} and the one value of d_{sb} .

Design of Bottom Slab

The bottom slab of a pressure conduit is subject to two possible controlling loads as shown in Figure 18

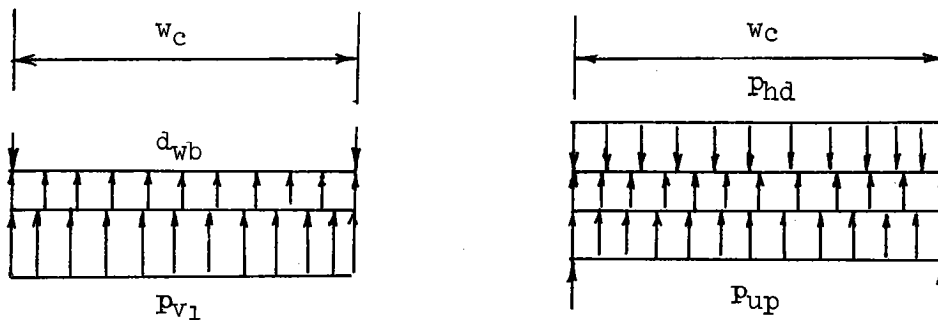

Figure 18. Loads for shear thickness of bottom slab.

The bottom slab may carry the dead weight of the top slab and the side-walls. Since t_b is as yet unknown, take $t_h = t_t + 1$, so

$$d_{wb} = \frac{150 \{ w_c t_t + (h_c + (2t_t + 1)/12)(t_{st} + t_{sb}) \}}{w_c + 2t_{sb}/12}$$

For the first loading, shear critical at distance (d)

$$t_b = d + 3.5$$

$$t_b = \frac{\frac{1}{2}(p_{v1} + d_{wb})w_c}{840 + (p_{v1} + d_{wb})/12} + 3.5$$

For the second loading, if the conduit is on earth $p_{up} = p_{v2} + d_{wb}$, if the conduit is on rock $p_{up} = 0$, therefore

$$t_b = d + 2.5$$

and, with shear critical at face

$$t_b = \frac{\frac{1}{2}(p_{hd} - p_{up})w_c}{840} + 2.5$$

where

d_{wb} = dead weight on bottom slab, in psf

t_b = thickness of bottom slab, in inches

d = effective depth, in inches

If $(p_{hd} - p_{up}) < 0$, the desired shear does not exist.

The larger of the two computed thicknesses controls.

Summary of Shear Design

The set of thicknesses t_t , t_{st} , t_{sb} , and t_b just obtained represents the minimum possible slab thicknesses consistent with the selected criteria for shear as a measure of diagonal tension. This set is the first trial set of thicknesses for which indeterminate analyses can be made and subsequent determinations of required steel areas can be obtained. It may be found necessary to increase one or more of these thicknesses in subsequent stages of the design.

Analyses of Corner Moments

With all conduit dimensions known, indeterminate analyses for moments can be performed. Before this is done, it is desirable that all unit loads on top, sides, and bottom slabs be evaluated for the seven load combinations previously established. these are

$$\begin{array}{l}
 P_{ti} = P_{vn} + d_{wt} \\
 P_{si} = P_{hn} \\
 P_{bi} = P_{vn} + d_{wb} \\
 \text{or} \\
 P_{bi} = 0
 \end{array}
 \left. \vphantom{\begin{array}{l} P_{ti} \\ P_{si} \\ P_{bi} \\ \text{or} \\ P_{bi} \end{array}} \right\}
 \begin{array}{l}
 n = 1 \text{ or } 2 \\
 i = 0, 1, 2, 3, 4, 5, 6
 \end{array}$$

for which,

$$d_{wb} = \frac{150 \{ w_c t_t + (h_c + (t_t + t_b)/12)(t_{st} + t_{sb}) \}}{w_c + 2t_{sb}/12}$$

Unit Load Analyses

Corner moments for seven external load combinations and two internal water loadings are required. Rather than perform these nine analyses, three unit load analyses, with the magnitudes of the unit load taken as unity, may be used to obtain corner moments for all but one of the internal water loadings. The analyses needed are shown in Figure 19

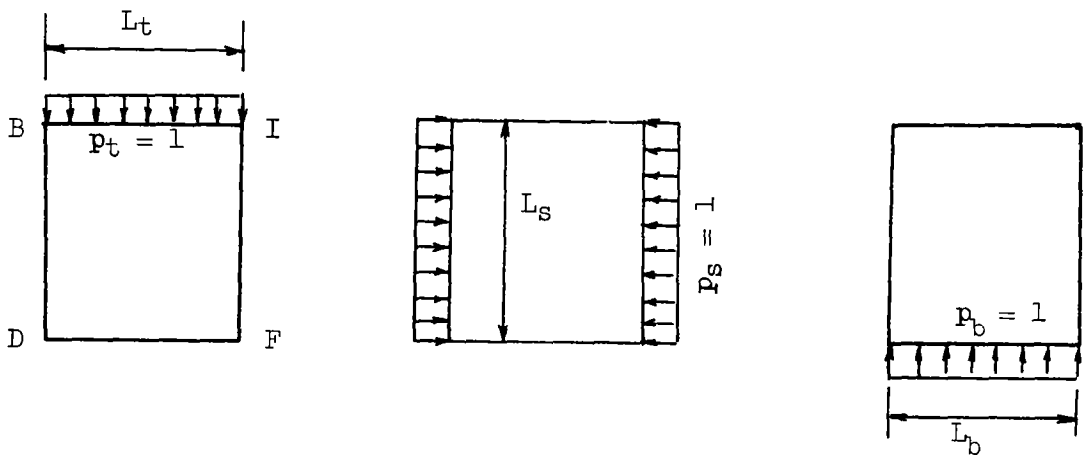

Figure 19. Loadings for unit load analyses.

The corner moments at B and D for each of the three unit loadings may be obtained from the general solutions for M_{BI} and M_{DF} previously derived. These moments in ft-lbs per lb of loading, are designated M_{But} , M_{Dut} , M_{Bus} , M_{Dus} , M_{Bub} , and M_{Dub} respectively. Immediately after M_{But} and M_{Dut} are obtained, a revised estimate of V_{ex} may be

computed when necessary as discussed on page 21.

Evaluation of External Load Corner Moments

Corner moments for a given load combination may be obtained as the sums of the respective unit load moments times the corresponding actual external loads. Thus, adopting the nomenclature $M_{Bi} = M_{BIi}$ and $M_{Di} = M_{DFi}$, where M_B and M_D take on the same Slope Deflection signs as M_{BI} and M_{DF} the moments in ft-lbs are

$$\left. \begin{aligned} M_{Bi} &= P_{ti}M_{But} + P_{si}M_{Bus} + P_{bi}M_{Bub} \\ M_{Di} &= P_{ti}M_{Dut} + P_{si}M_{Dus} + P_{bi}M_{Dub} \end{aligned} \right\} i = 0, 1, 2, 3, 4, 5, 6$$

Referring to the discussions on pages 10 and 11, note that the assumptions relating to sidewalls

$$(1) aL = bL = l/4(t_b + t_t) \text{ for } t_b > t_t$$

$$(2) t_s = l/2(t_{sb} + t_{st}) \text{ for } t_{sb} > t_{st}$$

as well as the assumption

$$(3) \text{ sidewall loading is uniform instead of trapezoidal}$$

may all cause the corner moments at B to be computed too high and the corner moments at D to be computed too low. That is, the errors may be additive and on the safe or unsafe side depending on the moment or other function under consideration. Therefore to partially account for the effects of the three assumptions, a second set of corner moments is computed in which the moments due to side loads are arbitrarily adjusted 10 percent. Now

$$\left. \begin{aligned} M_{Bi} &= P_{ti}M_{But} + 0.9P_{si}M_{Bus} + P_{bi}M_{Bub} \\ M_{Di} &= P_{ti}M_{Dut} + 1.1P_{si}M_{Dus} + P_{bi}M_{Dub} \end{aligned} \right\} i = 0, 1, 2, 3, 4, 5, 6$$

This second set of external load corner moments is used only in those instances when it is conservative to take a lower moment at B or a higher moment at D.

Analyses for Internal Water Loads

Moments due to pressure head loading may be computed using the unit load analyses

$$M_{Bhd} = -P_{hd}(M_{But} + M_{Bus} + M_{Bub})$$

$$M_{Dhd} = -P_{hd}(M_{Dut} + M_{Dus} + M_{Dub})$$

The minus signs are used since P_{hd} is an outward acting load.

Moments due to hydrostatic sidewall loading may be computed from the general solutions for M_{BI} and M_{DF} after the fixed end moments are obtained.

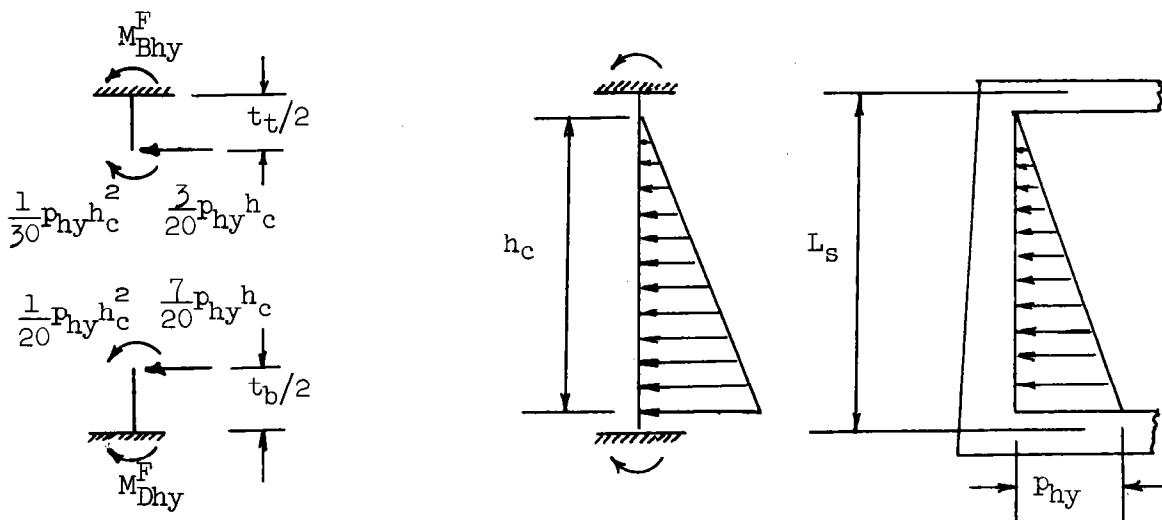

Figure 20. Fixed end moments for hydrostatic loading.

From the figure, the fixed end moments in ft-lbs are

$$M_{Bhy}^F = + \left(\frac{1}{30} p_{hy} h_c^2 + \frac{1}{160} p_{hy} h_c t_t \right)$$

$$M_{Dhy}^F = - \left(\frac{1}{20} p_{hy} h_c^2 + \frac{7}{480} p_{hy} h_c t_b \right)$$

where h_c is in ft and t_t and t_b are in inches.

Sense of Corner Moments

Confusion sometimes exists as to the sense of various moments. The Slope Deflection sign convention and the bending moment sign convention are independent of one another. The Slope Deflection convention is concerned with the sense of moments acting on joints (or on the ends of members). The bending moment convention is concerned with whether a moment causes tension on the inside or outside (sometimes top or bottom) of a member. Figure 21 shows the senses of various moments when the solutions for M_{Bi} and M_{Di} are positive in accordance with the adopted Slope Deflection convention.

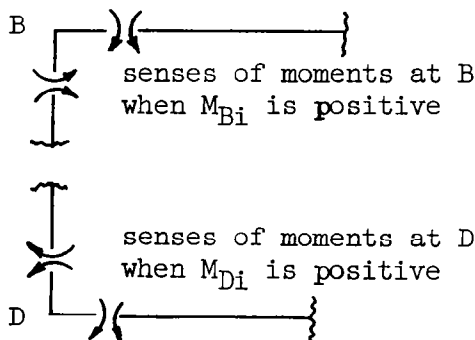
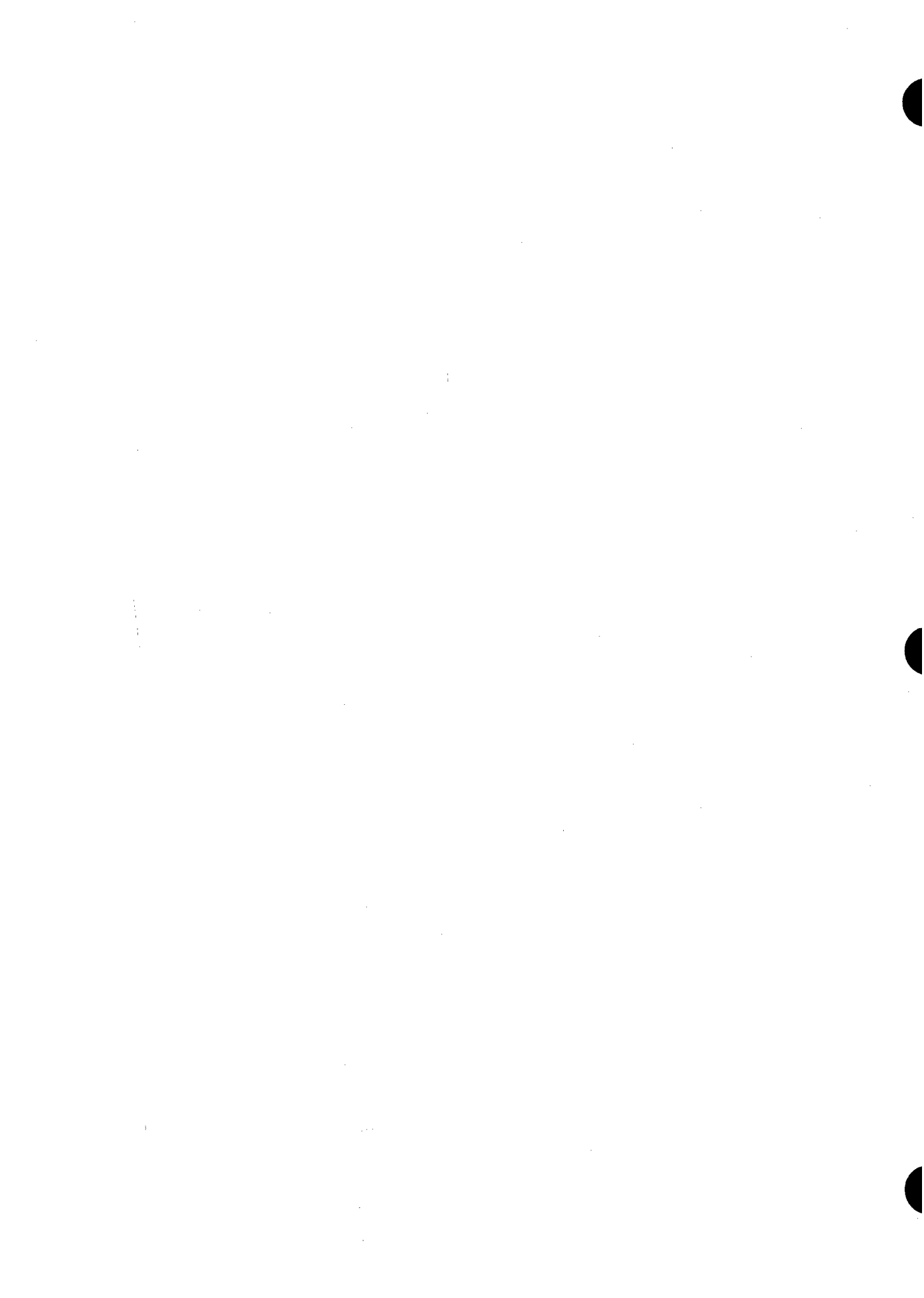

Figure 21. Sense of moments from Slope Deflection solution.



Steel Required by Combined Bending Moment and Direct Force

After slab thicknesses are known and corner moments for external and internal loads have been determined, the next step is to compute steel areas required at the fourteen locations given in Figure 1. In order to do this, there must be a procedure by which required areas may be obtained for any acceptable combination of moment and direct force. The load combination or combinations that may produce maximum required area for each design mode must also be recognized.

Treatment of Bending Moment and Direct Force

The procedure for determining required areas, to be general, must handle all cases of $M \geq 0$ and N either compression, tension, or zero. This is indicated schematically in Figure 22 which shows three statically equivalent force systems.

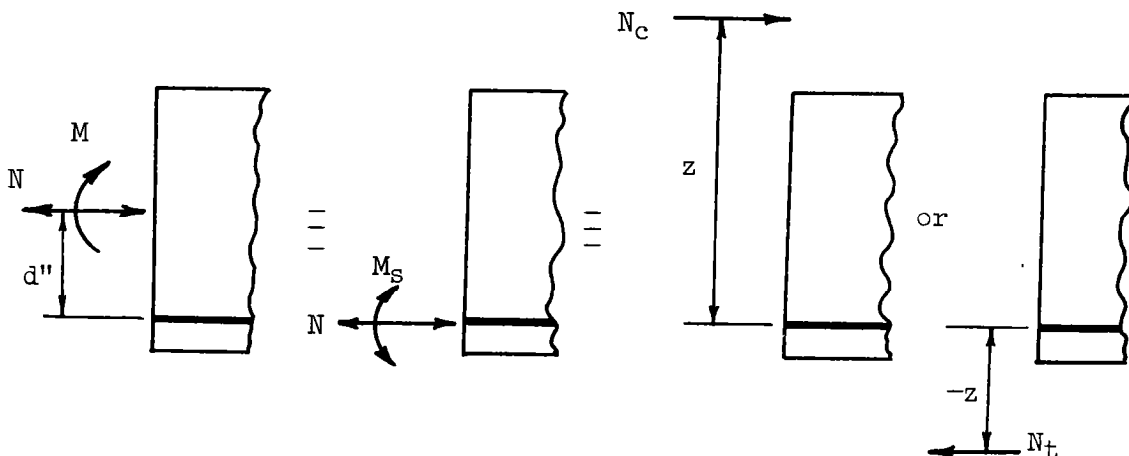

Figure 22. Range of values of moment and direct force.

Usual case, direct force at large eccentricity. - For the majority of combinations of moment and direct force, the procedure specified in National Engineering Handbook Section 6, subsection 4.2.2(c) applies and is followed. Thus, taking compressive direct force and clockwise moment in Figure 22 as positive

$$M_s = M + Nd''/12$$

and

$$12M_s = \frac{1}{2}f_c k j b d^2 = \frac{1}{2}b d^2 \left(\frac{f_s}{n}\right) \left(\frac{k}{1-k}\right) k j$$

from which k may be determined from the cubic equation

$$-\frac{1}{3}k^3 + k^2 + kF = F$$

where

$$F = \frac{12M_s}{\frac{1}{2}b d^2 \left(\frac{f_s}{n}\right)}$$

then

$$A = \frac{12M_s}{f_s j d}$$

and

$$A_s = A - \frac{N}{20000}$$

where M = moment about mid-depth of section in ft-lbs

M_s = moment about tension steel, in ft-lbs

N = direct force, in lbs

d'' = $d - t/2$, in inches

d = effective depth, in inches

f_s = steel stress, in psi

A = equivalent area, in sq. inches per ft of width

A_s = area, in sq. inches per ft of width

As stated in the criteria on page 16, solutions requiring the use of compression steel in bending are not acceptable since this in turn requires the use of stirrups or ties around the compression steel. Compression steel is not required if the actual effective depth at a section is not less than the effective depth required for balanced working stresses. Thus, if

$$d < d_{bal}$$

where

$$d_{bal} = \left(\frac{12M_s}{\frac{1}{2}f_c k j b} \right)^{1/2}$$

and

$$k = k_{bal} = 0.3902$$

$$j = j_{bal} = 0.8699$$

the effective depth is insufficient. If this condition has not already occurred more than an arbitrarily selected number of times (currently 9) the thickness of the particular section and slab is incremented so that $d \geq d_{bal}$. New unit loads incorporating corrected dead load effects are established, new indeterminate analyses are obtained, and new designs are attempted.

Unusual case, direct compressive force at small eccentricity. - In a few cases, where the direct force is compression and the moment is relatively small, the normal tension control theory for obtaining required area does not apply. This occurs when

$$\left(z = \frac{M_s}{N} \right) < (z_{bal} = 0.8699d)$$

These cases are considered in the compression control range in accordance with ACI 318-63 section 1407(b). Equation (14-9) may be used to derive an equation for an equivalent axial load from which the required steel area may be obtained. The equation for equivalent axial load may be written

$$P = G \left(1 + CD \frac{e}{t} \right) N$$

See ACI Publication SP-3; from Table 26, for $f_s = 16000$ psi and small p_g values, take $CD = 4.0$, from Table 23 for $f_c' = 4000$ psi, $f_s = 16000$ psi and small p_g values, take $G = 0.64$. For design, P is taken as the larger of

$$P = 0.64(1 + 4\frac{e}{t})N$$

or

$$P = N$$

From ACI Code sections 1402 and 1403

$$P = 0.85A_g(0.25f_c' + f_s p_g)$$

or the total required steel area is

$$A = \frac{1}{16000}(\frac{P}{0.85} - 12000t)$$

Assuming the opposite side of the section has at least $p_t = 0.001$, i.e., $0.001bt = 0.012t$ sq. in. of steel, the steel area required on the side under consideration is

$$A_s = \frac{1}{16000}(\frac{P}{0.85} - 12000t) - 0.012t$$

or

$$A_s = \frac{1}{16000}(\frac{P}{0.85} - 12000t) - 0.384$$

if t exceeds 32 inches.

In these relations

$e = 12M/N =$ eccentricity of direct compressive force, in inches

$P =$ equivalent axial load, in lbs

$f_c' = 4000$ psi

$A_g =$ gross area of column, in sq. inches

$p_g =$ gross steel ratio

Unusual case, direct tensile force at small eccentricity. - It is possible for the direct force in pressure conduits to be tension. When the direct force is tension and the bending moment is relatively small, the normal tension control theory does not hold. This occurs when

$$M_s \leq 0$$

These cases are considered in the direct tension range. The total required steel area is

$$A = -\frac{N}{20000}$$

Again, assuming the opposite side of the section has at least $p_t = 0.001$, i.e., $0.001bt = 0.012t$ sq. inches of steel, the steel area required on the side under consideration is

$$A_s = -\frac{N}{20000} - 0.012t$$

or

$$A_s = - \frac{N}{20000} - 0.384$$

if t exceeds 32 inches.

Load Combinations Producing Maximum Required Areas

Selection of the load combination or combinations that may produce maximum required steel area at a given location may be accomplished by experience, intuition, analysis, or combinations of these. It can not always be ascertained beforehand whether a particular function exists. However, if the function exists, the load combination or combinations that will produce the function can be determined.

Maximum moment plus associated direct force. - Table 1 lists the basic set or sets of loads and the external load combination for each design mode which may give maximum required steel areas at the midspans of the top slab, sidewall, and bottom slab. These results were determined by considering influence lines of the types shown for M_A and M_C in Appendix A and by considering deflected shapes due to internal water loads.

Table 1 . Loadings for midspan moments

Location (See Figure 1)	Earth Foundation		Rock Foundation	
	No Internal Water	With Internal Water	No Internal Water	With Internal Water
1	B1-LC#1	B2-LC#1 or B3-LC#1	B1-LC#1	B2-LC#1 or B3-LC#1
2	B1-LC#2	B1-LC#2 or B3-LC#2	B1-LC#5	B1-LC#5 or B3-LC#5
7	B1-LC#2	B1-LC#2 or B3-LC#2	B1-LC#5	B1-LC#5 or B3-LC#5
8	B1-LC#1	B2-LC#1 or B3-LC#1	B1-LC#1	B2-LC#1 or B3-LC#1
13	B1-LC#1	B2-LC#1 or B3-LC#1	B1-LC#1	B2-LC#1 or B3-LC#1
14	B1-LC#2	B1-LC#2 or B3-LC#2	B1-LC#5	B1-LC#5 or B3-LC#5

Table 2 lists the basic set of loads and the external load combinations for each design mode which may give maximum required steel areas at the faces of supports. These results were determined by considering influence lines of the type shown for M_B in Appendix A and by considering deflected shapes due to internal water loads. Alternate load combinations are given in some cases. The influence lines for moment correctly indicate the load combination producing maximum moment. However, the alternate load combination, although producing a smaller moment, may require a greater steel area because of the smaller direct force involved.

Table 2. Loadings for moments at face of supports.

Location (See Figure 1)	Earth Foundation				Rock Foundation			
	From Influence Line		Alternate		From Influence Line		Alternate	
	No Internal Water	With Internal Water	No Internal Water	With Internal Water	No Internal Water	With Internal Water	No Internal Water	With Internal Water
3	--	B3-LC#0			--	B3-LC#0		
4	B1-LC#3	B1-LC#3	B1-LC#1	B1-LC#1	B1-LC#6	B1-LC#6	B1-LC#4	B1-LC#4
5	--	B3-LC#0			--	B3-LC#0		
6	B1-LC#3	B1-LC#3	B1-LC#2	B1-LC#2	B1-LC#6	B1-LC#6	B1-LC#5	B1-LC#5
9	--	B3-LC#0			B1-LC#4	B3-LC#4		
10	B1-LC#3	B1-LC#3	B1-LC#2	B1-LC#2	B1-LC#3	B1-LC#3	B1-LC#2	B1-LC#2
11	--	B3-LC#0			B1-LC#4	B3-LC#4		
12	B1-LC#3	B1-LC#3	B1-LC#1	B1-LC#1	B1-LC#3	B1-LC#3	B1-LC#1	B1-LC#1

The conclusions reached in Table 2 neglect the fact that the maximum moment at a face of a support may be caused by a load combination other than the one producing the maximum corner moment. Thus Table 2 is not sufficient by itself to always determine maximum required steel areas at faces of supports. Table 3 supplements the previous table. It lists additional basic sets of loads and external load combinations which may give maximum areas at faces of supports. These additional results were determined by considering influence lines of the type shown in Appendix A for M at face of support in the top slab.

Table 3 . Additional loadings for face moments

Location (See Figure 1)	Earth Foundation		Rock Foundation	
	No Internal Water	With Internal Water	No Internal Water	With Internal Water
3	B1-LC#1	B2-LC#1 or B3-LC#1	B1-LC#1	B2-LC#1 or B3-LC#1
4	B1-LC#2	B1-LC#2	B1-LC#5	B1-LC#5
5	B1-LC#2	B1-LC#2 or B3-LC#2	B1-LC#2	B1-LC#2 or B3-LC#2
6	B1-LC#1	B1-LC#1	B1-LC#4	B1-LC#4
9	B1-LC#2	B1-LC#2 or B3-LC#2	B1-LC#6	B1-LC#6 or B3-LC#6
10	B1-LC#1	B1-LC#1	B1-LC#1	B1-LC#1
11	B1-LC#1	B2-LC#1 or B3-LC#1	B1-LC#1	B2-LC#1 or B3-LC#1
12	B1-LC#2	B1-LC#2	B1-LC#5	B1-LC#5

Maximum direct force plus associated moment. - Occasionally the maximum required steel area is governed by the maximum direct force plus associated moment rather than by maximum moment plus associated direct force. Maximum compressive direct forces occur with the conduit empty. Maximum tensile direct forces in the top slab and sidewalls occur, if they occur, with the conduit flowing full under pressure. The bottom slab, if the conduit is on rock, may carry direct tension when the conduit is empty. Table 4 lists the basic set of loads and external load combinations producing these maximum direct forces.

Table 4 . Loadings for maximum direct forces

Member	Compression	Tension
Top Slab	On earth Bl-LC#2 On rock Bl-LC#6	B3-LC#0
Sidewalls	Bl-LC#1	B3-LC#0
Bottom Slab	Bl-LC#3	On earth B3-LC#0 On rock B3-LC#4 On rock Bl-LC#4

Procedure at a Section

With the corner moments known for all external and internal loads, the design moment and direct force at a given section may be computed by statics for each of the basic sets of loads and external load combinations that must be considered. This is illustrated below for six locations and loadings. With the moment and direct force at a section known, the required steel area of interest can be determined as described beginning on page 31.

Location 4 - negative bending moment with loading Bl-LC#3. - Care must be exercised to ensure that statical moment, bending moment, and Slope Deflection moment signs are not confused and to ensure that units are accounted for correctly. To obtain the negative bending moment at the face of the support of the top slab for the indicated loading, observe Figure 23 and note the Slope Deflection sign of M_{B3} is positive. Then from statics and symmetry, letting M_{Bt} be the desired moment

$$M_{Bt} = M_{B3} - p_{t3}(L_t^2 - w_c^2)/8$$

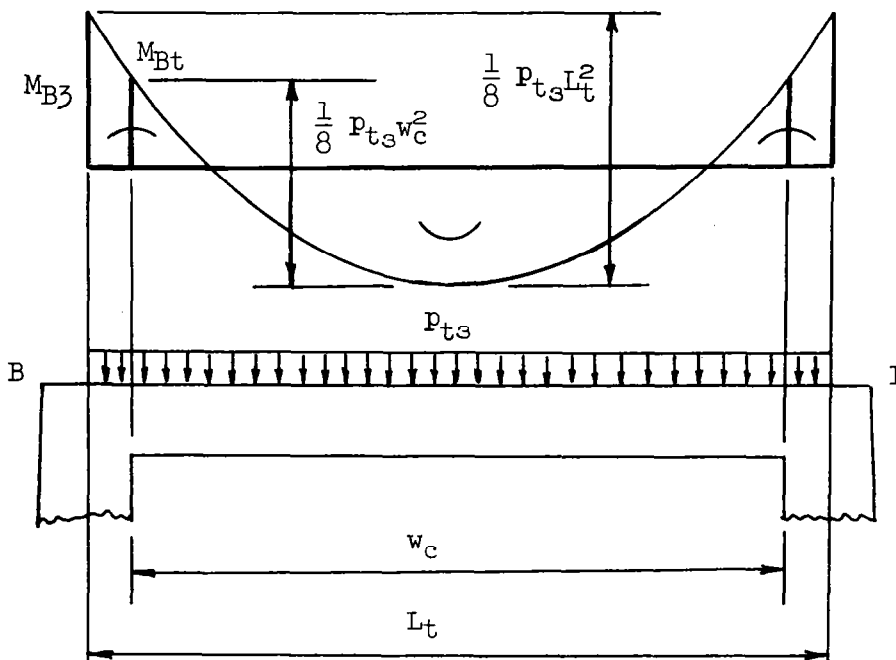

Figure 23. Moments in top slab with loading Bl-LC#3.

If, as written, $M_{Bt} < 0$ the desired moment does not exist. The associated direct force in the top slab may be obtained as the sum of three components, see Figure 24

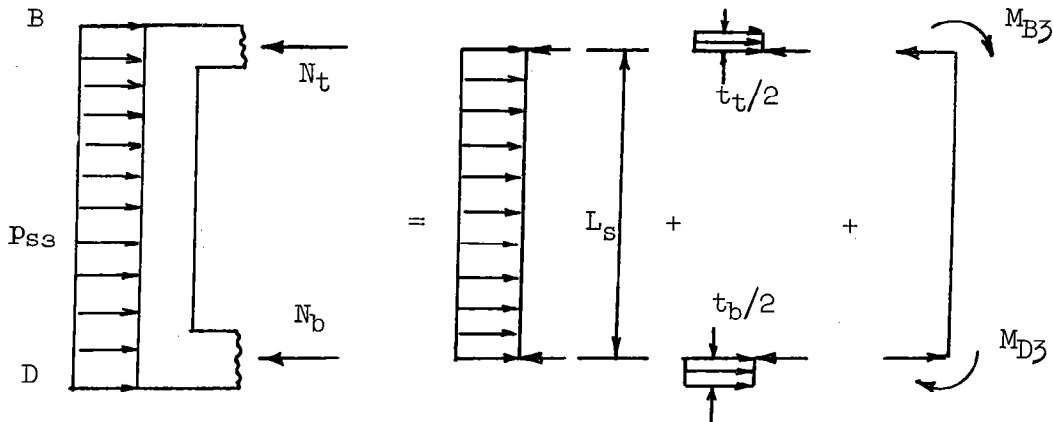

Figure 24. Components of direct force in top and bottom slabs with loading Bl-IC#3.

Thus, noting the component due to corner moments is written for positive Slope Deflection signs

$$N_t = p_{s3} (L_s/2 + t_t/24) + (M_{B3} + M_{D3})/L_s$$

where moments are in ft-lbs and

p_{s3} = sidewall unit load, in psf

N_t = direct force in top slab, in lbs

L_t = top slab span, in ft

L_s = sidewall span, in ft

w_c = clear width of conduit, in ft

t_t = inches

With M_{Bt} and N_t known, the required steel at location 4 (negative steel at face of support of top slab) can be determined for the indicated loading.

Location 6 - negative bending moment with loading Bl-IC#3. - Due to the lack of sidewall symmetry, the negative bending moment at the face of the top support of the sidewall for the indicated loading is best obtained by first computing the sidewall reaction at the top and then using the free body diagram shown in Figure 25.

Thus from statics, letting M_{Bs} be the desired moment

$$R = p_{s3} L_s/2 + (M_{B3} + M_{D3})/L_s$$

$$M_{Bs} = M_{B3} - R t_t/24 + p_{s3} t_t^2/1152$$

and

$$N_s = P_{t3}(L_t + t_{st}/12)/2$$

If, as written, $M_{Bs} < 0$ the desired moment does not exist. With M_{Bs} and N_s known, the required steel at location 6 (negative steel at face of top support of sidewall) can be determined for the indicated loading.

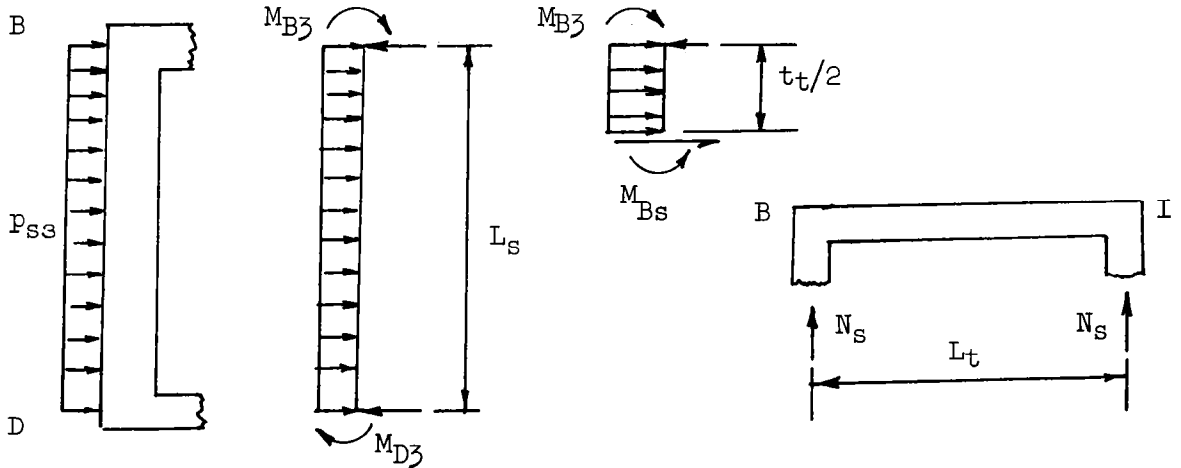

Figure 25. Moment and direct force in sidewall with loading B1-LC#3.

Location 1 - positive bending moment with loading B2-LC#1. - This case includes internal hydrostatic sidewall loading due to the conduit flowing full as an open channel.

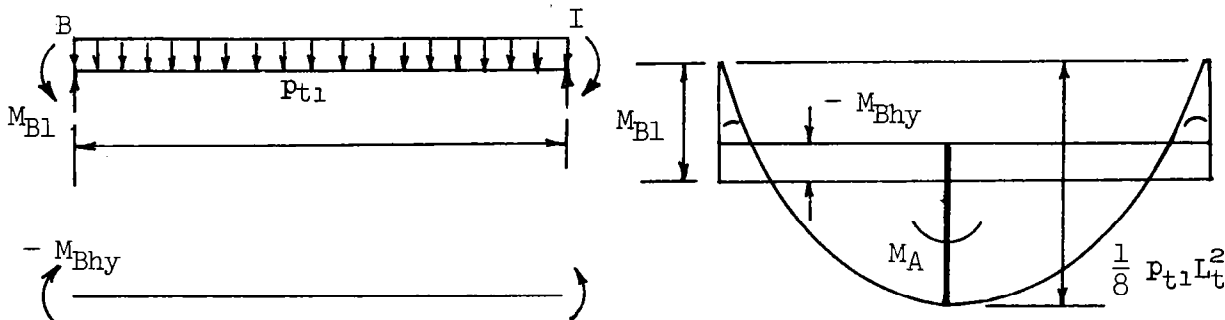

Figure 26. Moments in top slab with loading B2-LC#1.

The moment at B due the hydrostatic loading is M_{Bhy} ; by Slope Deflection signs, it is a negative moment. Thus from statics, letting M_A be the desired moment

$$M_A = \frac{1}{8} P_{t1} L_t^2 - M_{B1} + (-M_{Bhy})$$

If, as written, $M_A < 0$ the desired moment does not exist. The associated direct force may be obtained as the sum of four components, see Figure 27. The direct force in the top slab decreases as the external sidewall load approaches a triangular distribution. Required steel area increases as the direct force decreases. The first component of the direct force is therefore adjusted to partially account for a trapezoidal distribution Hence

$$N_t = P_{s1}(L_s/3 + t_t/24) - (\frac{1}{2}P_{hy}h_c)(h_c/3 + t_b/24)/L_s + (M_{B1} + M_{D1} + M_{Bhy} + M_{Dhy})/L_s$$

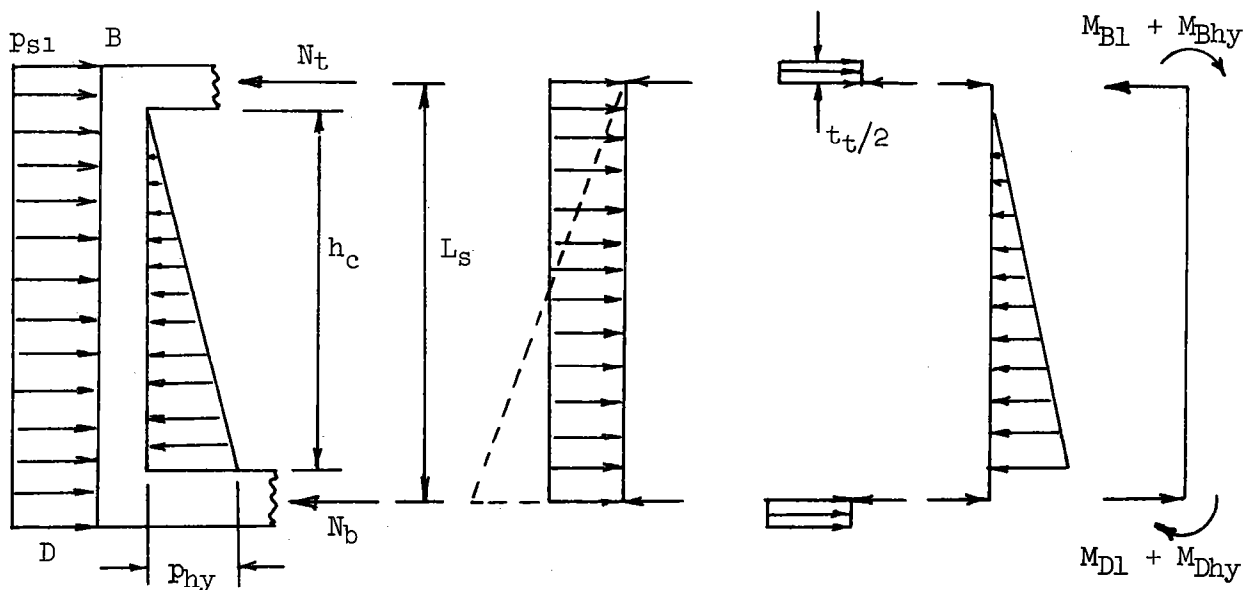

Figure 27. Components of direct force in top and bottom slabs with loading B2-IC#1

With M_A and N_t known, the required steel at location 1 (positive steel in center of top slab) can be determined for the indicated loading.

Location 7 - positive bending moment with loading B3-IC#2. - This case includes internal water loads due to the conduit flowing full as a pressure conduit. It will produce maximum required area for conduits on earth foundations only when the proportions of the conduit are such that the moment at the center of the sidewall due to internal pressure head is positive and larger in magnitude than the moment due to internal hydrostatic sidewall loading. Normally loading B1-IC#2 will govern this location. With either loading, the section of maximum positive moment is unknown due to the lack of symmetry. This section is located and the moment evaluated. The steel required at this section is determined and recorded for location 7.

From Figure 28 noting the corner moments are written for positive Slope Deflection signs and thus any negative values are automatically correct

$$R = (P_{s2} - P_{hd})L_s/2 - \left(\frac{1}{2}P_{hy} h_c\right)(h_c/3 + t_b/24)/L_s$$

$$+ (M_{B2} + M_{Bhd} + M_{Bhy} + M_{D2} + M_{Dhd} + M_{Dhy})/L_s$$

$$V_p = R - (P_{s2} - P_{hd}) x_p + \frac{1}{2}P_{hy}(x_p - t_t/24)(x_p - t_t/24)/h_c$$

The section of maximum positive moment is determined by setting $V_p = 0$ and solving for x_p . With little error, the last term $(x_p - t_t/24)/h_c$ may be taken as $1/2$, then

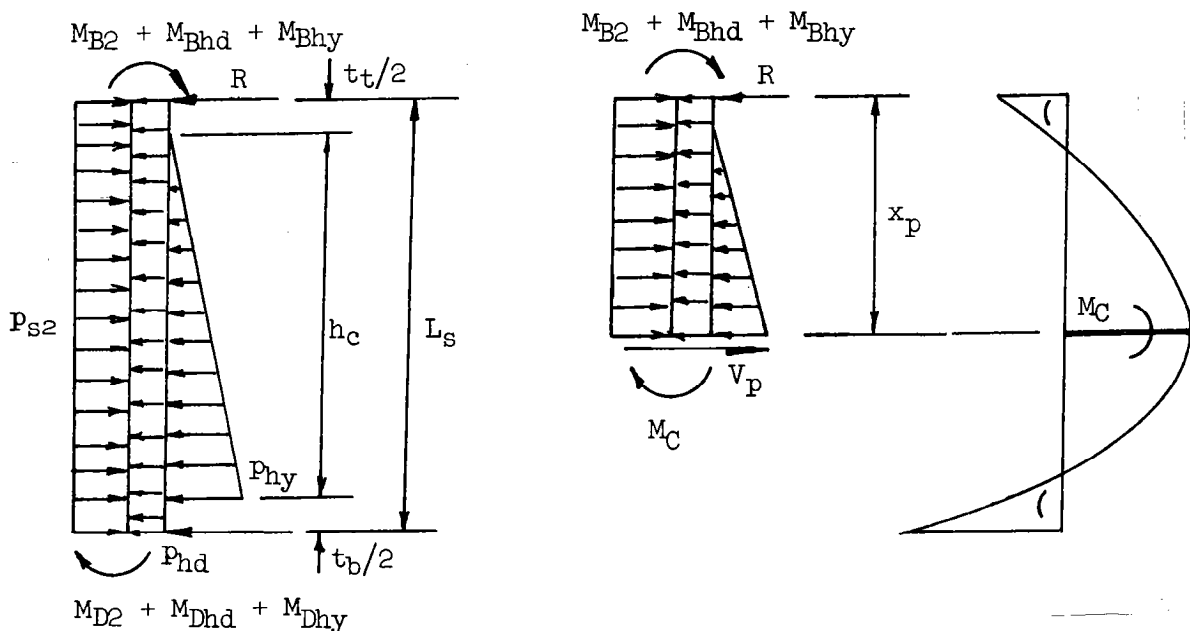

Figure 28. Moments in sidewall with loading B3-LC#2

$$x_p = \frac{R - p_{hy} t_t/96}{p_{s2} - p_{hd} - p_{hy}/4}$$

Finally, letting M_C be the desired moment

$$M_C = R x_p - (M_{B2} + M_{Bhd} + M_{Bhy}) - (p_{s2} - p_{hd}) x_p^2/2 \\ + p_{hy} (x_p - t_t/24)^3 / (6h_c)$$

In these expressions moments are in ft-lbs, pressures are in psf, thicknesses are in inches, and distances including x_p are in feet. If, as written, $M_C < 0$ the desired moment does not exist. The associated direct force is

$$N_s = (p_{t2} - p_{hd})(L_t + t_{st}/12)/2$$

With M_C and N_s known, the required steel at location 7 (positive steel nominally in center of sidewall) can be determined for the indicated loading. The thickness at the section of maximum positive moment is

$$t = t_{st} + (t_t/2 + 12 x_p)/32$$

Bottom slab, section at midspan - maximum direct compression. - The maximum direct compression on the bottom slab is produced by loading B1-LC#3 and may be obtained as the sum of three components, see Figure 24 used above. The direct force in the bottom slab increases as the external sidewall load approaches a triangular distribution. The first component of the direct force is therefore adjusted to partially account for a trapezoidal load distribution.

$$N_b = p_{s3}(2L_s/3 + t_b/24) - (M_{B3} + M_{D3})/L_s$$

If, as written, $N_b \leq 0$ compressive direct force does not exist in the bottom slab.

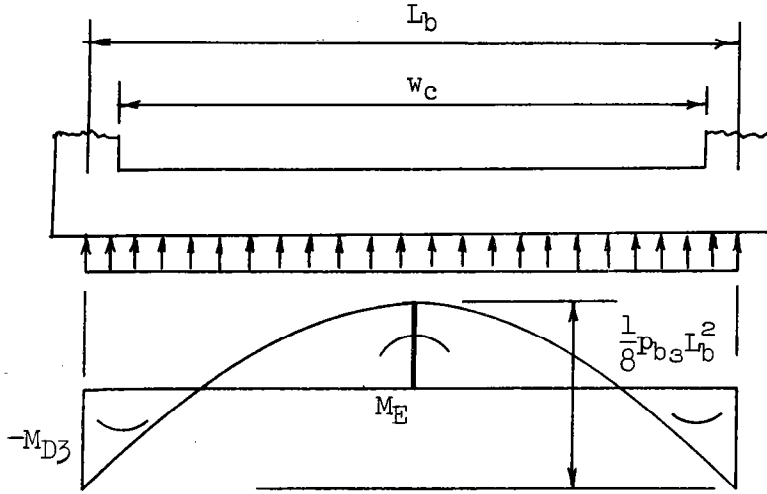

Figure 29. Moments in bottom slab with loading B1-LC#3.

From statics and symmetry, letting M_E be the associated moment and noting by Slope Deflection signs, the corner moment is negative.

$$M_E = \frac{1}{8} p_{bs} L_b^2 - (-M_{D3})$$

The sign of M_E is unknown. If M_E is positive as written, the required steel computed from N_b and M_E applies to location 13. If M_E is negative, the required steel applies to location 14.

Bottom slab, section at midspan - maximum direct tension. - The maximum direct tension in the bottom slab is sometimes produced by loading B3-LC#0. Using this loading as an illustration

$$N_b = (p_{s0} - p_{hd})L_s/2 + p_{s0} t_b/24 - \left(\frac{1}{2} p_{hy} h_c\right)(2h_c/3 + t_t/24)/L_s$$

$$- (M_{B0} + M_{Bhd} + M_{Bhy} + M_{D0} + M_{Dhd} + M_{Dhy})/L_s$$

If, as written, $N_b \geq 0$ tensile direct force does not exist in the bottom slab. From statics and symmetry, letting M_E be the associated moment

$$M_E = (p_{s0} - p_{hd})L_b^2/8 - (-M_{D0}) + M_{Dhd} + M_{Dhy}$$

If M_E is positive as written, the required steel computed from N_b and M_E applies to location 13. If M_E is negative, the required area applies to location 14.

Anchorage of Positive Steel

Safe practice requires that the tension in any bar at any section be adequately developed on each side of that section. Thus the inside (positive) steel at the corners of the conduit must be provided sufficient anchorage whenever it is established that tension exists in the bar under some combination of loads. The anchorage may be provided by standard hooks or by embedment length if there is enough distance.

Positive Steel at Face of Support

It is not necessary that separate analyses be performed to establish whether the positive steel at locations 3, 5, 9, and 11 is ever in tension. The determinations are made and recorded at the time the required area at these locations is computed. Whenever the tensile area required at one of these locations is greater than zero, then anchorage into the support is required.

Positive Steel at Corner Diagonals

Tension may occur in the inside steel at the corner diagonals even though it is possible tension never occurs in the corresponding steel at the support face. Hence the existence of tension in the inside steel at the diagonals is investigated.

Referring to Figure 30 tension will exist in the bottom steel of sketches (a) through (e) whenever:

for (a), N is tension and $M > Nd''/12$

for (d), N is zero and $M > 0$

for (e), N is compression and $M > N(t/2 - d/3)/12$

recall that compressive direct force is positive and tensile direct force is negative.

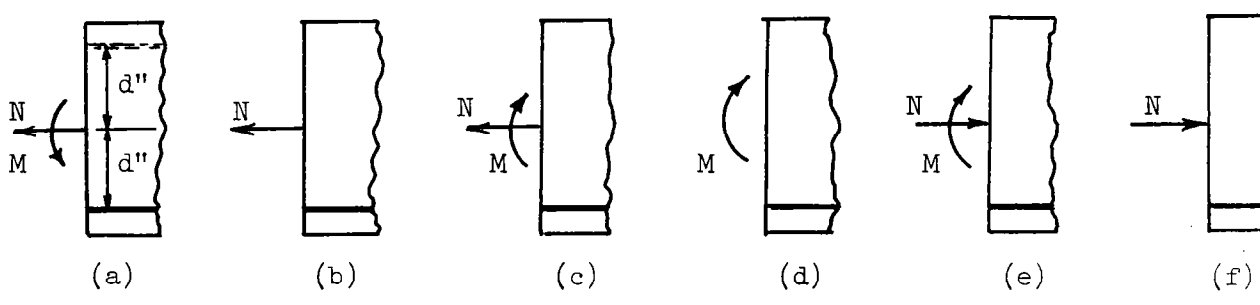

Figure 30. Existence of tension in bottom steel.

The expression $M > N(t/2 - d/3)/12$ comes from $M_s > N(2d/3)/12$ since $M_s = M + Nd''/12$ and $d'' = d - t/2$

Top corner diagonal. - Tension in the inside steel at the top corner can occur only when internal water loading is included in the design. This is loading B3-LC#0. In the analysis of the corner diagonal, the assumption is made that the resultant tensile force in the inside steel, if tension exists, is located approximately at the point on the diagonal where the normal from the point of intersection of the inside steels pierces the diagonal. This point is conservatively taken as 3.535 inches from the inside corner of the conduit.

$$t_k = (t_t^2 + t_{st}^2)^{1/2}$$

$$d_k \approx t_k - 3.535$$

$$d_k'' = d_k - t_k/2$$

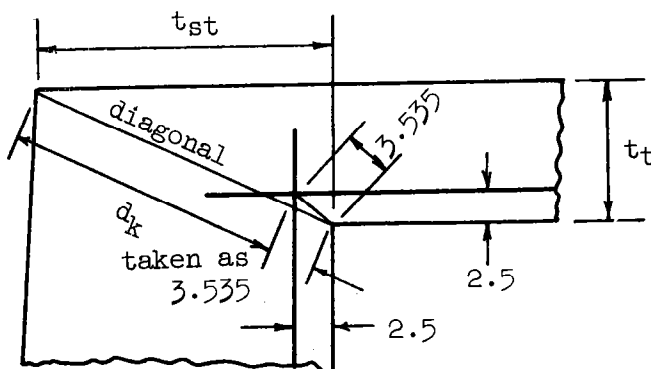

Figure 31. Top corner geometry.

Letting M_B be the moment on the corner diagonal and changing signs so that clockwise moments on the diagonal are positive

$$M_B = - (M_{BO} + M_{Bhy} + M_{Bhd})$$

the components of the direct force on the diagonal are

$$N_s = (p_{to} - p_{hd})(L_t + t_{st}/12)/2$$

and

$$N_t = p_{so}(L_s/3 + t_t/24) - (\frac{1}{2}p_{hy} h_c)(h_c/3 + t_b/24)/L_s$$

$$- p_{hd} L_s/2 + (M_{BO} + M_{Bhd} + M_{Bhy} + M_{DO} + M_{Dhd} + M_{Dhy})/L_s$$

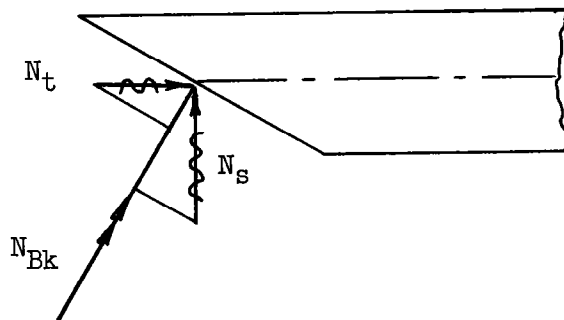
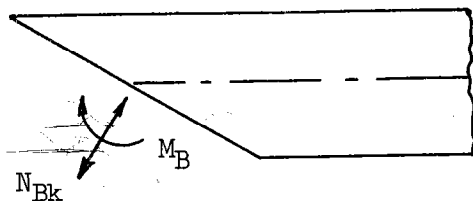

Figure 32. Resultants on top corner diagonal.

The resultant direct force on the diagonal is

$$N_{Bk} = N_t(t_t/t_k) + N_s(t_{st}/t_k)$$

With the resultant moment and direct force on the diagonal known, tests are performed to determine if conditions lie within the limits indicated above, that is, does tension exist on the inside steel at the diagonal.

Bottom corner diagonal. - Tension in the inside steel at the bottom corner can occur with the loadings given in Table 5.

Table 5. Loadings for tension in bottom corner inside steel

Earth Foundation		Rock Foundation	
No Internal Water	With Internal Water	No Internal Water	With Internal Water
--	B3-LC#0	B1-LC#4	B3-LC#4

The analysis for the bottom corner diagonal is similar to that for the top corner. For example, for loading B3-LC#4, letting M_D be the moment on the corner diagonal

$$M_D = (M_{D4} + M_{Dhy} + M_{Dhd})$$

and

$$N_s = -p_{hd}(L_b + t_{sb}/12)/2$$

$$N_b = p_{s4}(L_s/2 + t_b/24) - (\frac{1}{2}p_{hy} h_c)(2h_c/3 + t_t/24)/L_s - p_{hd} L_s/2 - (M_{B4} + M_{Bhy} + M_{Bhd} + M_{D4} + M_{Dhy} + M_{Dhd})/L_s$$

so

$$N_{Dk} = N_b(t_b/t_k) + N_s(t_{sb}/t_k)$$

where

$$t_k = (t_b^2 + t_{sb}^2)^{1/2}$$

With M_D and N_{DK} known, tests again discern whether the inside steel at the diagonal is in tension.

Spacing Required by Flexural Bond

Flexural bond stresses must be held within tolerable values whenever a bar is in tension. It is therefore necessary to determine the maximum shear that can exist at any section under consideration when the steel under investigation at the section is acting in tension. This maximum shear is sometimes less than the maximum shear that can ever exist at the section.

Relation to Determine Required Spacing

For steel bar sizes #5 through #11 and for $f_c' = 4000$ psi, the allowable flexural bond stress is inversely proportional to bar diameter, D . Thus the number of bars required per foot of width at a section is independent of bar size. The number of bars required is obtained by

$$n\pi D = \Sigma o = \frac{V}{u_j d} = \frac{V}{\left(\frac{C\sqrt{f_c'}}{D}\right)\left(\frac{7}{8}d\right)}$$

or

$$n = \frac{V}{(\pi C\sqrt{f_c'})\left(\frac{7}{8}d\right)}$$

Since the number of bars per foot can be determined, the allowable spacing of the bars is obtained by

$$s = \frac{12}{n} = \frac{12\pi C\sqrt{f_c'}\left(\frac{7}{8}d\right)}{V}$$

for tension top bars $C = 3.4$ and

$$s = 7,093d/V$$

for other tension bars $C = 4.8$ and

$$s = 10,015d/V$$

where

s = center to center spacing of bars, in inches

d = effective depth at the section, in inches

V = shear at the section, in lbs.

Note that it is theoretically possible to determine the minimum acceptable bar size at a section when required steel area and spacing is given. This is not done since it is felt desirable to allow the exercise of judgement in the selection of actual sizes and spacings of bars.

Load Combinations Producing Minimum Required Spacing

The flexural bond allowable steel spacing at a particular location is computed only after it has been determined the tensile area required in bending at that location is greater than zero. Table 6 lists the basic set

or sets of loads and the external load combinations that may produce maximum shear at the section under consideration when the indicated steel is acting. In some places more than one loading is listed for a particular steel location and design mode. If in a design, it is determined that the steel is in tension at that location then the only loadings investigated to determine the smallest allowable spacing are the loadings which produce tension in the steel for that design.

Procedure at a Section

The computation of bond spacing is illustrated below for three locations in the top slab. Computations for locations in the sidewalls and bottom slab are similar except that conditions in the sidewalls are complicated by the lack of symmetry. Note that the spacings computed for the positive steel at locations 1, 7, and 13 are really the spacings required at the respective points of inflection as shown on Figure 1.

Location 1 - with loading B1-IC#1. - If tension occurs in the top slab positive steel for this loading: the points of inflection are located, the shear at the points of inflection is obtained, and the required bond spacing is computed.

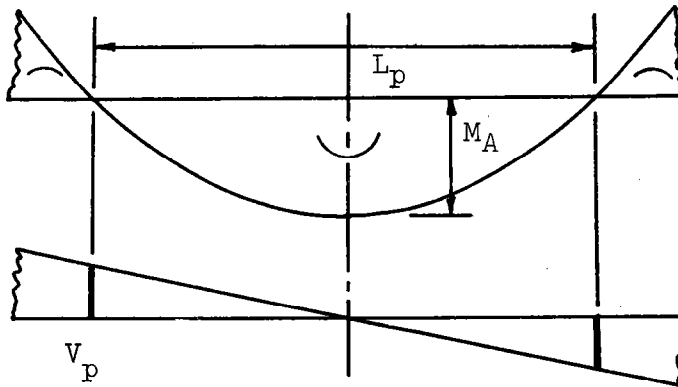

Figure 33. Points of inflection in top slab with loading B1-IC#1.

From symmetry, assuming M_A is the moment at the center of the top slab

$$L_p = \left(\frac{8M_A}{P_{t1}} \right)^{1/2}$$

and

$$V_p = P_{t1} L_p / 2$$

so

$$s = 10,015 d_t / V_p$$

where d_t is the effective depth of the top slab.

Location 1 - with loadings B2-IC#1 and B3-IC#1. - When internal water load is included in the design, it is not known beforehand which of the indicated loadings will govern the spacing. Usually the moment at the center of the top slab due to the pressure head loading is negative, when this is so, loading B2-IC#1 controls. However, in some designs

Table 6 . Loadings for flexural bond

Location (see Figure 1)	Earth Foundation		Rock Foundation	
	No Internal Water	With Internal Water	No Internal Water	With Internal Water
1	B1-IC#1	B2-IC#1 B3-IC#1	B1-IC#1	B2-IC#1 B3-IC#1
2	--	--	--	--
3	B1-IC#1	B2-IC#1 B3-IC#1 B3-IC#0	B1-IC#1	B2-IC#1 B3-IC#1 B3-IC#0
4	B1-IC#1 B1-IC#2	B1-IC#1 B1-IC#2	B1-IC#1 B1-IC#2	B1-IC#1 B1-IC#2
5	B1-IC#2	B1-IC#2 B3-IC#2 B3-IC#0	B1-IC#2	B1-IC#2 B3-IC#2 B3-IC#0
6	B1-IC#0 B1-IC#2	B1-IC#0 B1-IC#2	B1-IC#4 B1-IC#6	B1-IC#4 B1-IC#6
7	B1-IC#2	B1-IC#2 B3-IC#2	B1-IC#5	B1-IC#5 B3-IC#5
8	--	B2-IC#0	B1-IC#4	B1-IC#4 B2-IC#0
9	B1-IC#2	B1-IC#2 B3-IC#2 B3-IC#0	B1-IC#4 B1-IC#6	B1-IC#4 B1-IC#6 B3-IC#4 B3-IC#6
10	B1-IC#1 B1-IC#3	B1-IC#1 B1-IC#3	B1-IC#1 B1-IC#3	B1-IC#1 B1-IC#3
11	B1-IC#1	B2-IC#1 B3-IC#1 B3-IC#0	B1-IC#1	B2-IC#1 B3-IC#1 B3-IC#4
12	B1-IC#1 B1-IC#2	B1-IC#1 B1-IC#2	B1-IC#1 B1-IC#2	B1-IC#1 B1-IC#2
13	B1-IC#1	B2-IC#1 B3-IC#1	B1-IC#1	B2-IC#1 B3-IC#1
14	--	--	--	--

this moment may be positive. For illustration assume it is positive, then let M_A'' be the moment at the center of the top slab due to loading B2-IC#1 and M_A''' be the moment due to loading B3-IC#1. From Figure 34

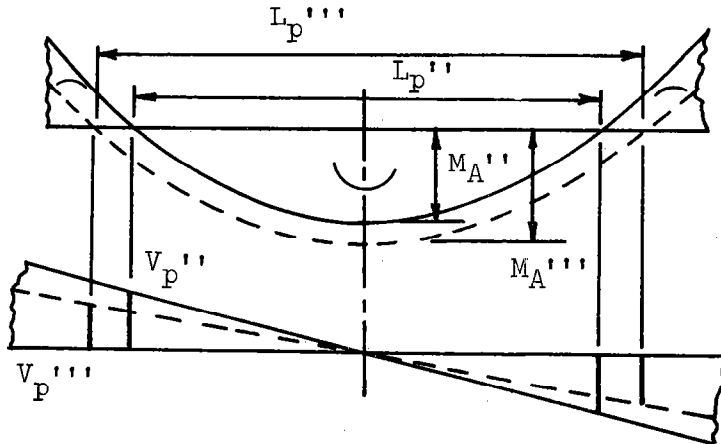

Figure 34. Points of inflection with loadings B2-IC#1 and B3-IC#1.

either V_p'' or V_p''' may control spacing. Thus

$$L_p'' = \left(\frac{8M_A''}{p_{t1}} \right)^{1/2} \quad L_p''' = \left(\frac{8M_A'''}{p_{t1} - p_{hd}} \right)^{1/2}$$

and

$$V_p'' = p_{t1} L_p''/2 \quad V_p''' = (p_{t1} - p_{hd}) L_p'''/2$$

so

$$s'' = 10,015 d_t/V_p'' \quad s''' = 10,015 d_t/V_p'''$$

The smaller spacing with its distance from the center of the span to the point of inflection are taken as the answer.

Location 3 - with loading B3-IC#0. - In some designs loadings B2-IC#1 and/or B3-IC#1 will cause tension in the steel at location 3, if this occurs, they will require a smaller spacing than loading B3-IC#0.

The shear at the face of the support in the top slab for loading B3-IC#0 is

$$V_{Bt} = (p_{t0} - p_{hd})w_c/2$$

so

$$s = 10,015 d_t/V_{Bt}$$

Location 4 - with loadings B1-IC#1 and B1-IC#2. - If both loadings cause tension in the steel at location 4, loading B1-IC#1 controls. However, in some designs only loading B1-IC#2 causes tension in this steel. In either event, the depth below the negative steel is checked to determine whether the steel qualifies as tension top bars or as other tension bars.

Summary of Design

Figure 35 presents a summary flow chart showing the sequence of the design process discussed on the preceding pages. The basic logic of the computer program prepared and used to design the Standard Single Cell Rectangular Conduits parallels this summary flow chart.

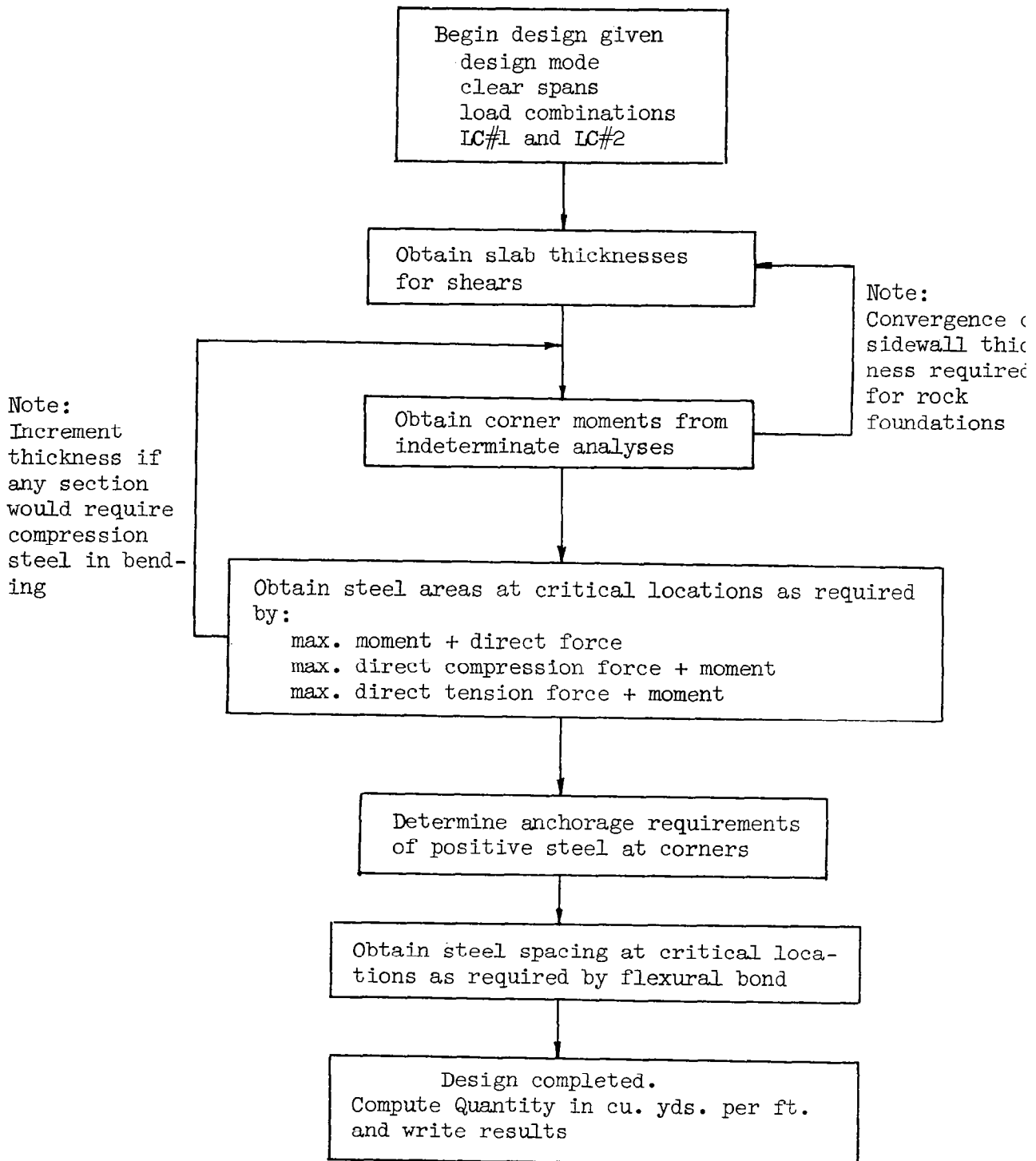
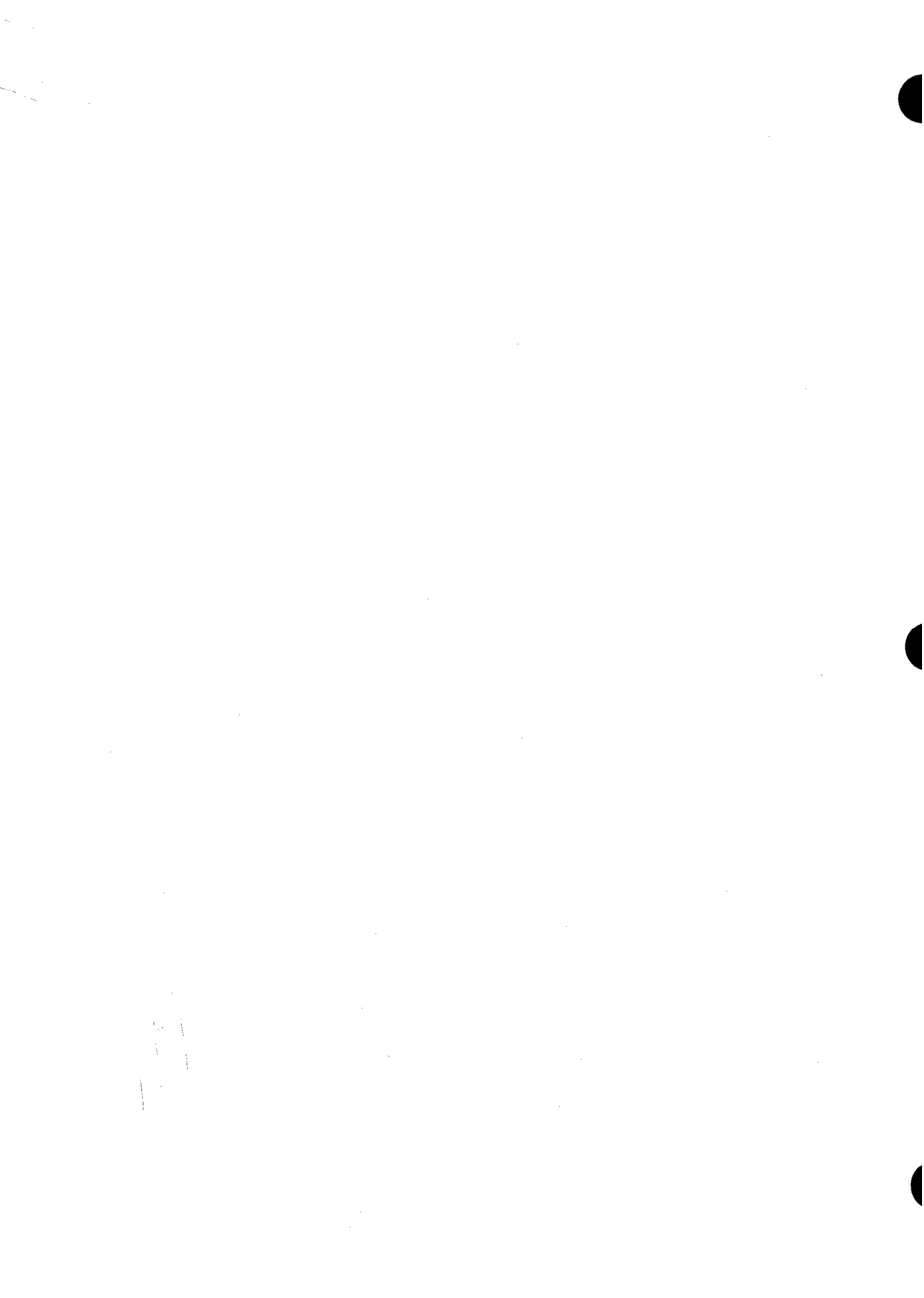

Figure 35. Summary flow chart of design process.



Appendix A

Some Qualitative Influence Lines for Inward Acting Applied Loads

The three influence lines for moment, drawn below, suggest various theoretical loading patterns and actual load combinations as shown.

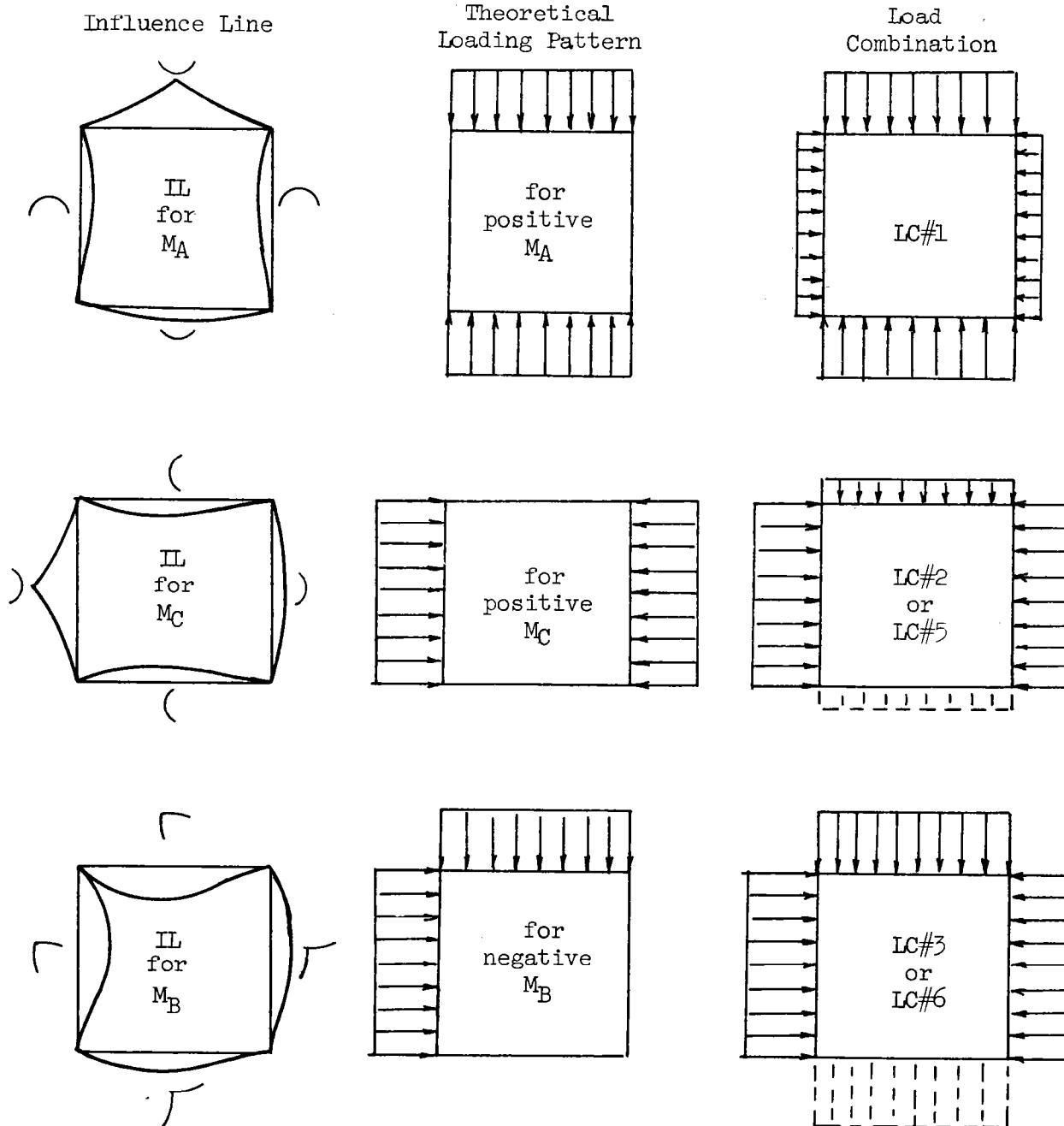

Three additional influence lines for different functions are given below. These, together with the preceding influence lines, may be used as models to obtain other influence lines as may be desired.

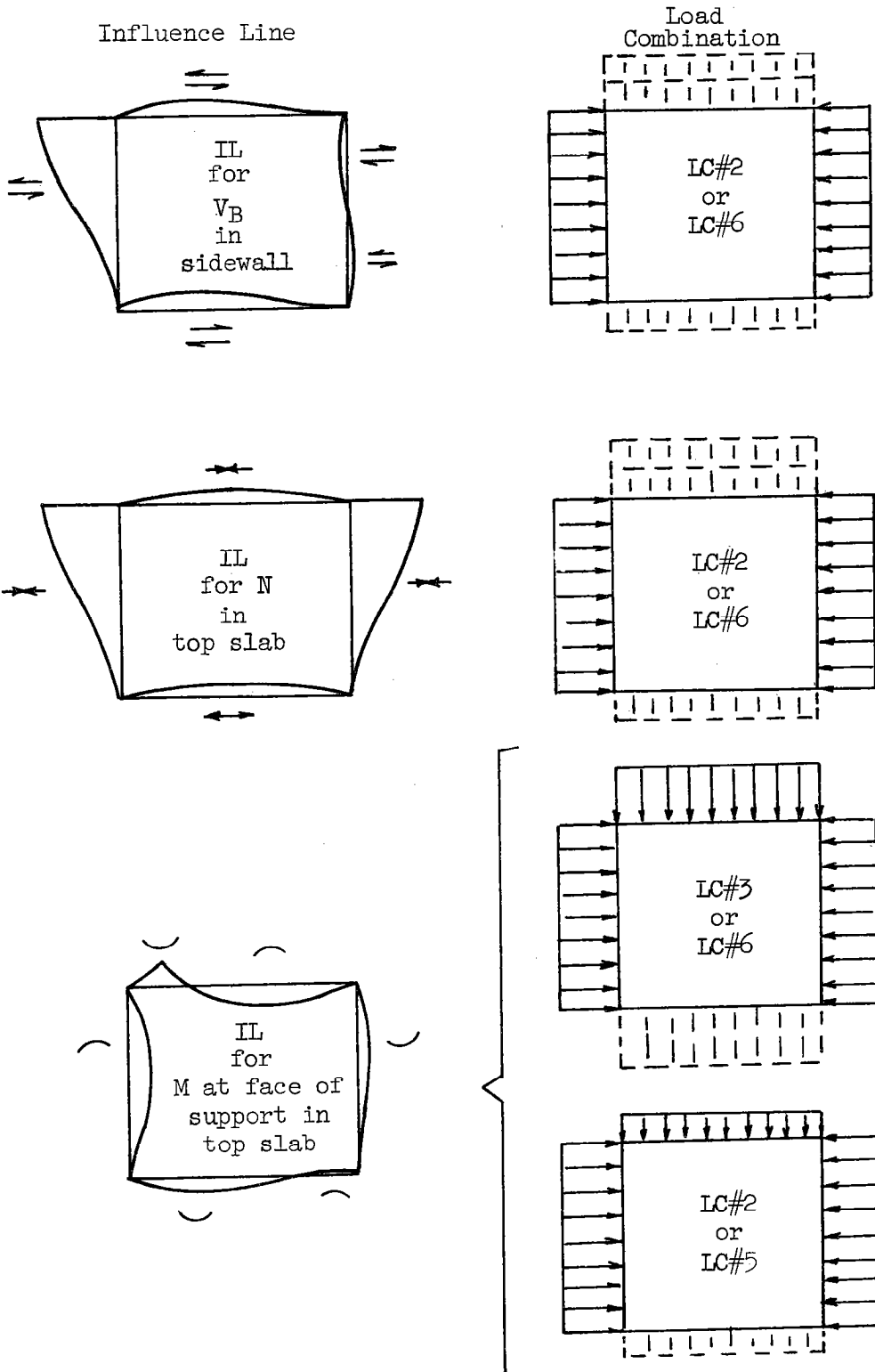
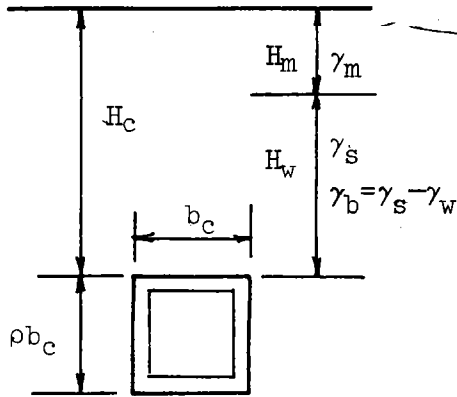

Illustration of Existence of Load Combinations



The following shows one situation which gives rise to various load combinations. Two conditions are recognized.

- (1) Initial (construction) condition
Shears along sides of interior prism have not yet developed.
- (2) Developed (long term) condition
Shears have completely developed along sides of interior prism.

Initial Condition - moist

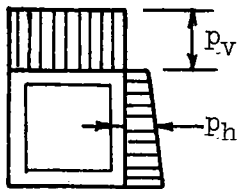

$$P_v = \gamma_m H_c$$

$$P_h = K_o (\gamma_m H_c + \gamma_m \rho b_c / 2)$$

Initial Condition - saturated

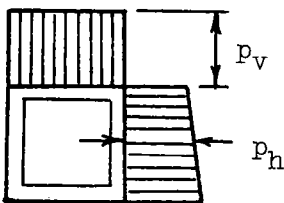

$$P_v = \gamma_m H_m + \gamma_b H_w + \gamma_w H_w$$

$$P_h = K_o (\gamma_m H_m + \gamma_b H_w + \gamma_b \rho b_c / 2) + \gamma_w (H_w + \rho b_c / 2)$$

(Select high K_o)

Developed Condition - moist

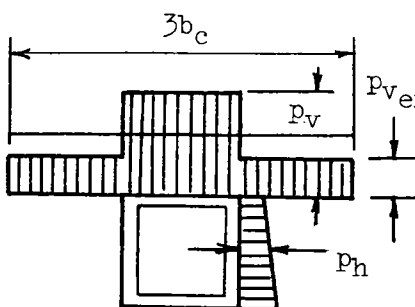

$$P_v = C_p \gamma_m b_c \quad \text{from TR-5}$$

$$P_{v \text{ ext.}} = \frac{3\gamma_m H_c - C_p \gamma_m b_c}{2}$$

$$P_h = K_o \left(\frac{3\gamma_m H_c - C_p \gamma_m b_c}{2} + \gamma_m \rho b_c / 2 \right)$$

(Select low K_o)

($3b_c$ is an approximation used for design purposes)

Developed Condition - saturated

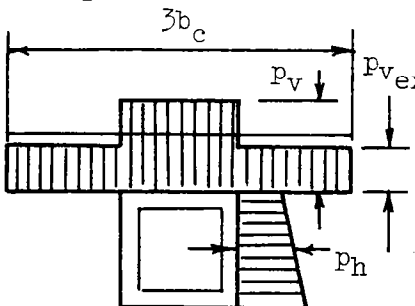

$$\gamma_{\text{wtd}} = \frac{\gamma_m H_m + \gamma_b H_w}{H_c}$$

$$P_v = C_p \gamma_{\text{wtd}} b_c + \gamma_w H_w$$

$$P_{v \text{ ext.}} = \frac{3\gamma_{\text{wtd}} H_c - C_p \gamma_{\text{wtd}} b_c}{2} + \gamma_w H_w$$

$$P_h = K_o \left(\frac{3\gamma_{\text{wtd}} H_c - C_p \gamma_{\text{wtd}} b_c}{2} + \gamma_b \rho b_c / 2 \right) + \gamma_w (H_w + \rho b_c / 2)$$

(Select high K_o)

